

TECHNICAL DATA

Dimensions

Dimensions (WxDxH)	26" x 27" x 38.1"
Output (lb/24hr)	160 lbs
Bin Capacity	80 lbs
Net Weight	121 lbs
Gross Weight	144 lbs
Packaging Dimensions (WxDxH)	30.7" x 29.3" x 35.4"
Ice Cube Size half cube	.86"x.86".86"

Cooling

Refrigerant	R290
Temperature Display	Yes
Temperature Controller	Digital
Condenser Unit	Air
Compressor	Secop

Construction

Exterior Material	304 series stainless steel
Interior Material	Polyethylene
Water Filter Capacity	2.2 GPM

Electrical

Voltage	115
Power	451W
Hz	60

PLAN VIEW

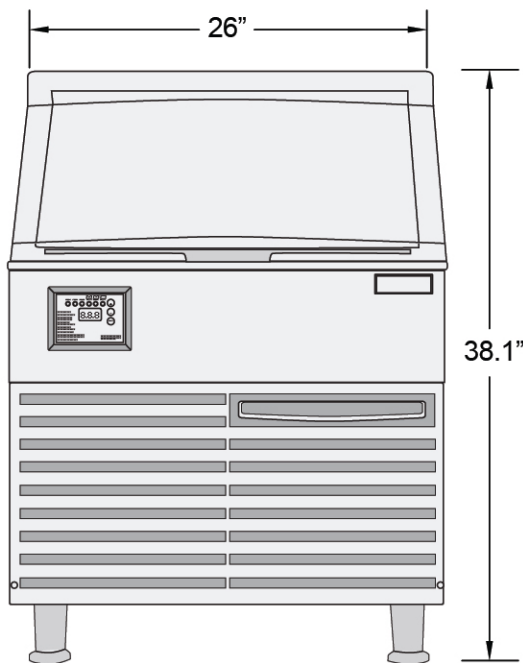

Front View

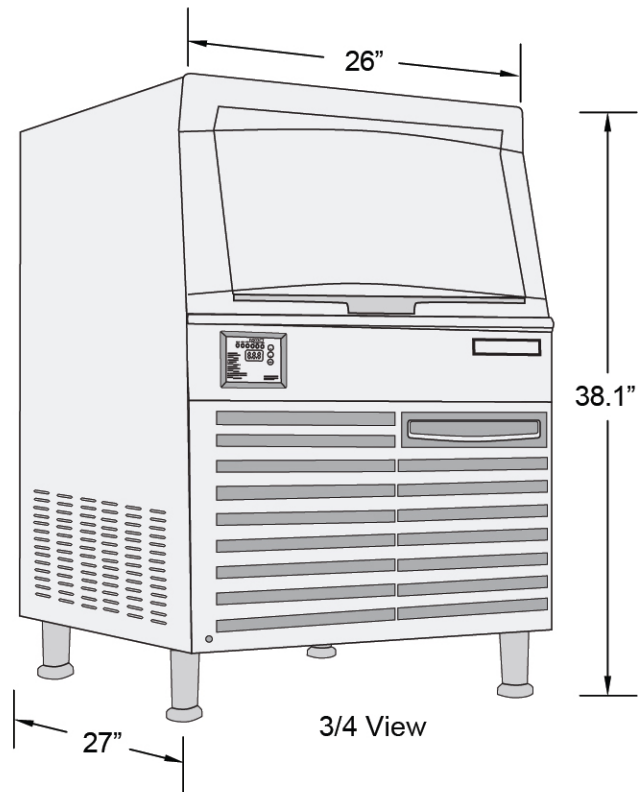

3/4 View

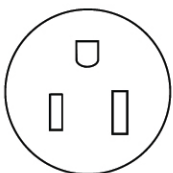

NEMA 5-15P

SUIM-160

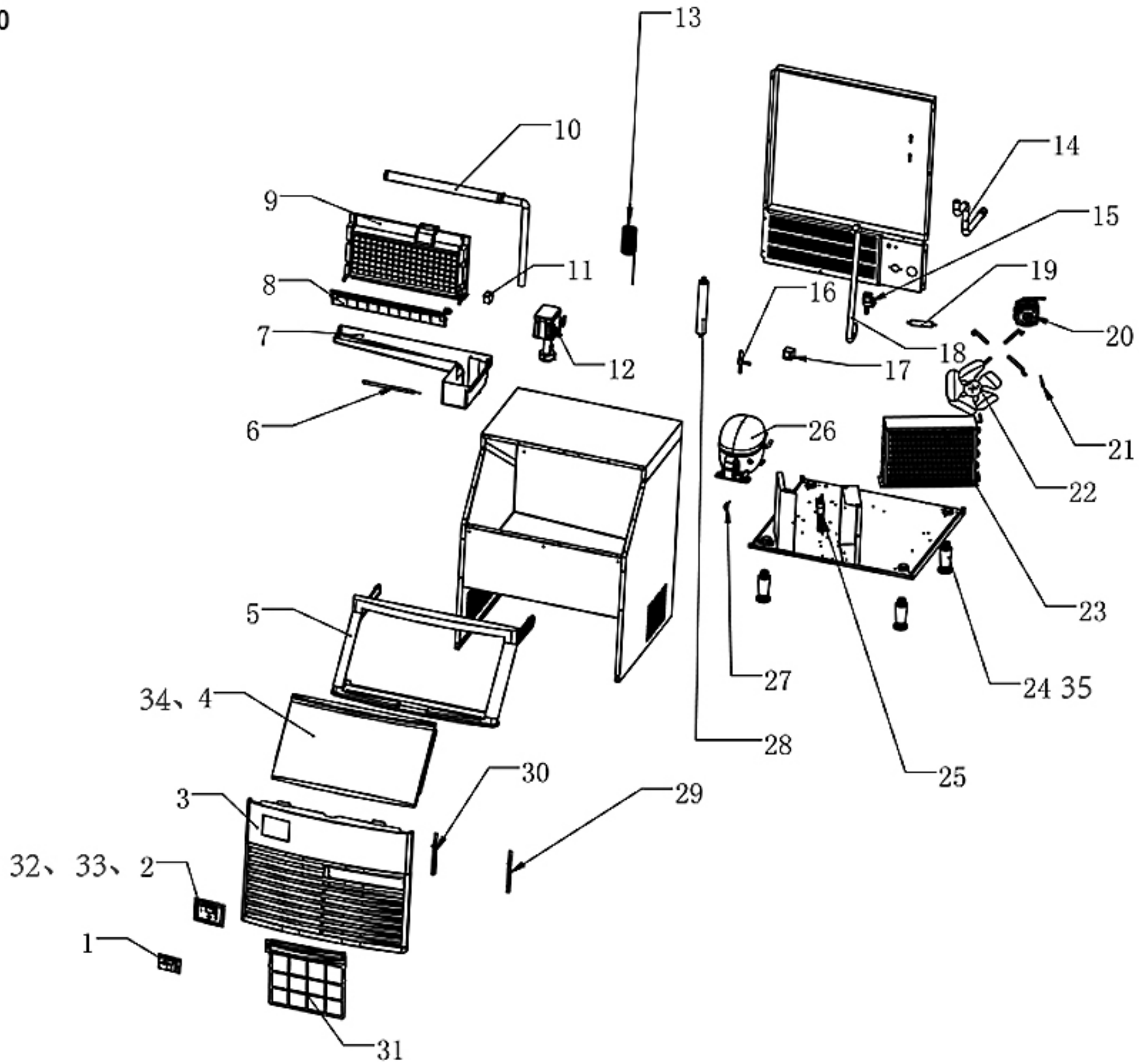

NO.	Part Name	Factory Part NO.
1	DISPLAY PANEL	03.012.043
2,32,33	CONTROL PANEL	05.004.005
		05.004.006
		18.001.039
3	FRONT VENTILATION WINDOW	05.015.013
4,34	DOOR PANEL ASSEMBLY	05.013.016
		05.013.018
5	DOOR FRAME ASSEMBLY	05.014.009
6	COLD LIGHT	06.017.003
7	SINK-160	05.001.005
8	SKATEBOARD (PARTS OF EVAPORATOR)	03.004.003
9	EVAPORATOR	03.003.006
10	SPRINKLER TUBE ASSEMBLY (PARTS OF EVAPORATOR)	SL.FB.32480654.00
11	ICE FULL SENSOR	03.013.008
12	WATER PUMP	03.009.005
13	CAPILLARY	02.002.006
14	OFF-BOARD DRAIN	17.009.001
15	INLET VALVE	04.003.010
16	DEFROST VALVE BODY	04.005.003
17	DEFROST VALVE COIL	04.007.006
18	SILICONE HOSE	09.005.003
19	DRY FILTER	02.005.002
20	FAN	03.006.011
21	CONDENSATION SENSOR	04.010.008
22	FAN BLADE	03.007.001
23	CONDENSER	03.005.008
24,35	FOOT ASSEMBLY	17.007.003
		17.007.004
25	PC BOARD	03.011.038
26	LED LIGHT REED SWITCH MAGNETIC SWITCH	06.016.005
27	COMPRESSOR DLE6.5CN	03.001.096
28	GAS-LIQUID SEPARATOR	02.003.008
29	FILTER RIGHT CARD SLOT-60/80/100/12	05.016.024
30	FILTER LEFT CARD SLOT-60/80/100/12	05.016.023
31	VENTILATION WINDOW FILTER	05.016.022