



Service Manual, 1 Gallon Brewers

Models Included

- TP1T
- TP1TT
- TP1S
- TP1ST

CAUTION: Equipment must be installed to comply with applicable federal, state, and local plumbing/electrical codes.

CAUTION: Follow this setup procedure before attempting to use this unit. Failure to follow these instructions can result in injury and/or void of warranty.

CAUTION: DO NOT connect the unit to hot water supply. The inlet valve is not rated for hot water.



ISO 9001:2008 REGISTERED

WILBUR CURTIS CO., INC.
6913 West Acco Street
Montebello, CA 90640-5403
For the latest information go to
www.wilburcurtis.com
Tel: 800-421-6150
Fax: 323-837-2410

Important Safeguards/Symbols

This equipment is designed for commercial use. Any servicing other than cleaning and routine maintenance should be performed by an authorized Wilbur Curtis Company Service Technician.

- DO NOT immerse the unit in water or any other liquid
- To reduce the risk of fire or electric shock, DO NOT open service panels. There are no user serviceable parts inside.
- Keep hands and other items away from hot areas of the unit during operation.
- Never clean with scouring powders or harsh chemicals.

Symbols:



WARNINGS – To help avoid personal injury



Important Notes/Cautions – from the factory



Sanitation Requirements

INSTALLATION

This Curtis unit is pre-set and ready to go from the factory.

Factory settings for this unit are:

- Brew Temperature = 200°F
- Water Bypass = On LARGE & MEDIUM brew only
- Brew Volume = Set to vessel requirements (specific based on model).

System Requirements:

- Water Supply 20 – 90 PSI (minimum flow rate of 1 gpm)
- Electrical: See electrical schematic.

SETUP STEPS

1. The unit should be level (left to right - front to back), on a secure surface.
2. Connect the water line to the water inlet fitting on the rear of the unit. Water volume flow to the machine should be consistent. Use tubing sized sufficiently to provide a minimum flow rate of one gallon per minute.

NOTE: A water filtration system must be used to help maintain trouble-free operation. In areas with extremely hard water, we highly recommend the use of a Curtis approved water filter. For our full line of filters, please log on to www.wilburcurtis.com. A water filtration system will greatly prolong the life of the unit and enhance the quality and taste of the product.



NSF International requires the following water connection:

1. A quick disconnect or additional coiled tubing (at least 2x the depth of the unit) is required so that the unit can be moved for cleaning.
 2. This unit must be installed with adequate backflow protection to comply with applicable federal, state and local codes.
 3. Water pipe connections and fixtures directly connected to a portable water supply shall be sized, installed and maintained in accordance with federal, state, and local codes.
3. Connect the unit to electrical outlet with appropriate amperage rating (see serial tag on machine).
 4. Once power has been supplied to the unit, flip the toggle switch to the 'ON' position (located on the rear of the unit), the water tank will begin to fill. When the water level in the tank reaches the probe, the heating element(s) will turn on.
 5. Water in the heating tank will require approximately a half hour before reaching operating temperature (factory setting of 200°F). Where applicable, turn on the Universal Control Module (UCM). When the unit reaches operating temperature, it will display "READY TO BREW".

Your Curtis G3 Brewer is Factory Pre-Set for Optimum Performance.

After connection to water and power; the rear toggle switch must be on. You will hear a beep sound, indicating power is available to the controller.

The control displays **WILBUR CURTIS**. Press ON/OFF button and the screen will display **T-PRO - SHORT CURTIS**. After three seconds, **CURTIS FILLING** is displayed.

Water will fill the tank (approximately 2-3 minutes depending on water flow rate). When the proper level is reached **CURTIS HEATING** will appear on the screen. It takes approximately 20 minutes to reach setpoint temperature of 200°F.

Control will display **CURTIS READY TO BREW** when temperature reaches the setpoint (200°F). Unit is now ready to brew.

BREWING INSTRUCTIONS

Use only coffee or water in the ThermoPro dispenser. Do not use the server to dispense any other beverage. Preheating the server with hot water is recommended. The single head brewer is show below, the twin head brewer is similar.

1. Place a clean and empty server on the deck. Server should be centered below the brewcone of the brewer.
2. Make sure the unit is up to brewing temperature and the LCD screen reads READY TO BREW.
3. Place a filter in the brewcone and pour in the correct measure of ground coffee for the brew volume.
4. Slide the brewcone into the brew rails.
5. Select and press desired brew button (LARGE or SMALL). The unit will start the brew cycle.
6. Allow coffee in the brewcone to drip out completely before removing the insulated server.

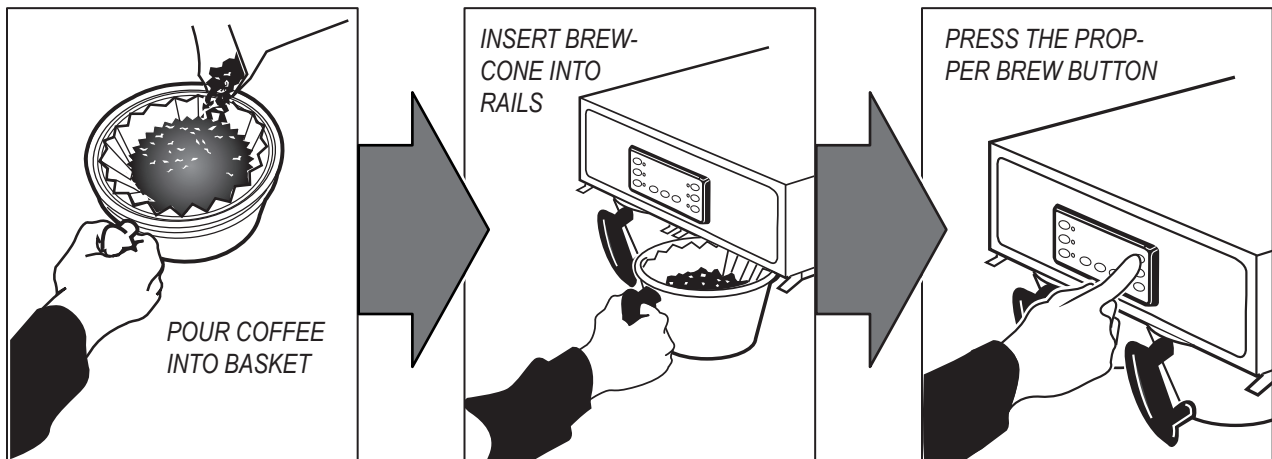

WARNING – THERMOPRO SERVERS MAY BE HEAVY WHEN FILLED.
CARE MUST BE TAKEN WHEN TRANSPORTING TO AVOID DROPPING OR SPILLING.

Control Module Menu Tree

The flow chart displays the sequence of menu item that can be accessed through the UCM. Various menu items will immediately exit the programming mode when selected. Other menu items, when selected, will continue to the next item in the menu list.

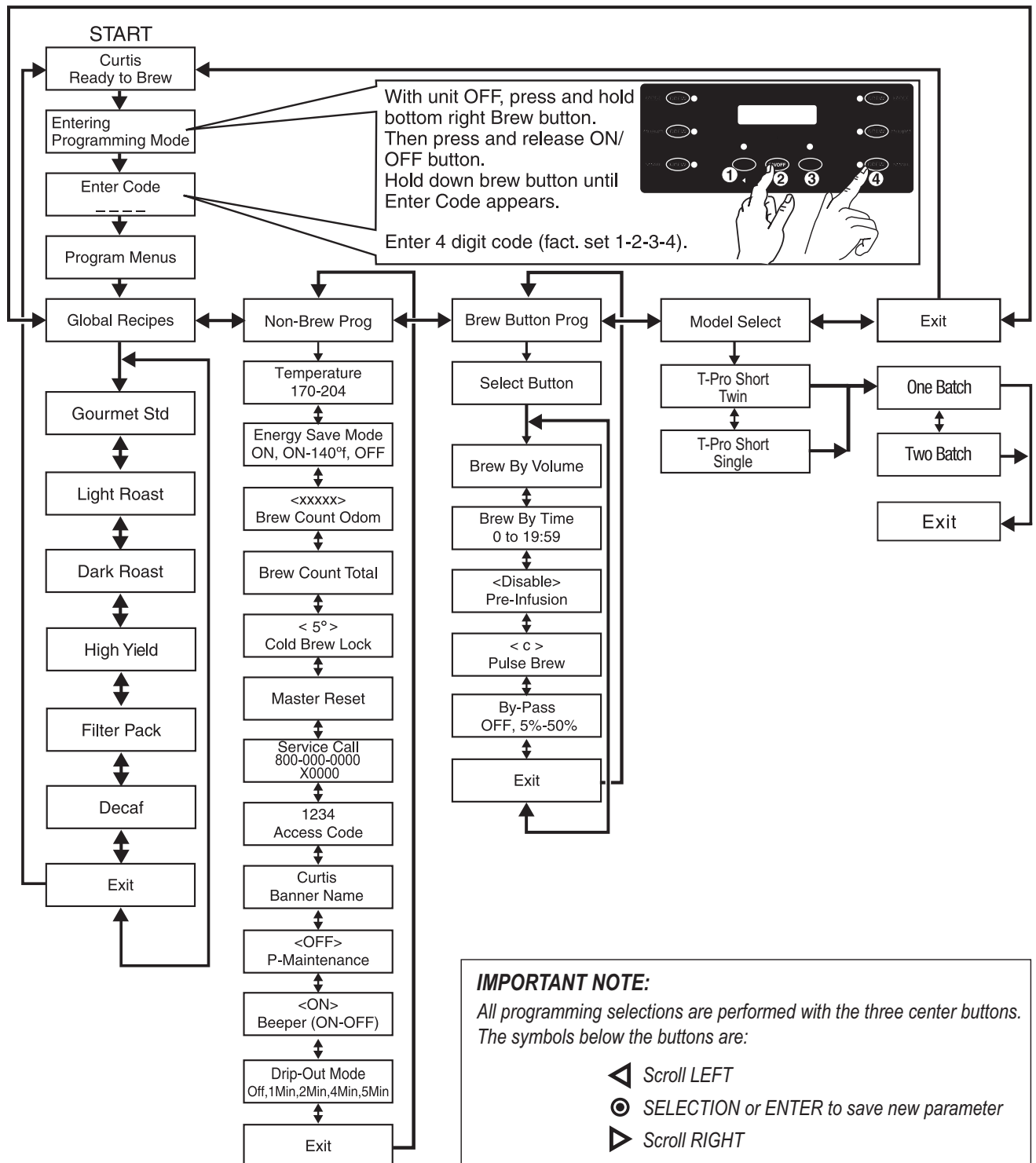

Tank Temperature Check

To check the temperature of the water within the heating tank, make sure brewer is on and Ready to Brew is displayed. Press and hold the ▷ button (see illustration, page two) for 5 seconds. The water temperature inside the tank will be displayed.

PARTS DIAGRAMS
Twin 1 Gallon Brewer

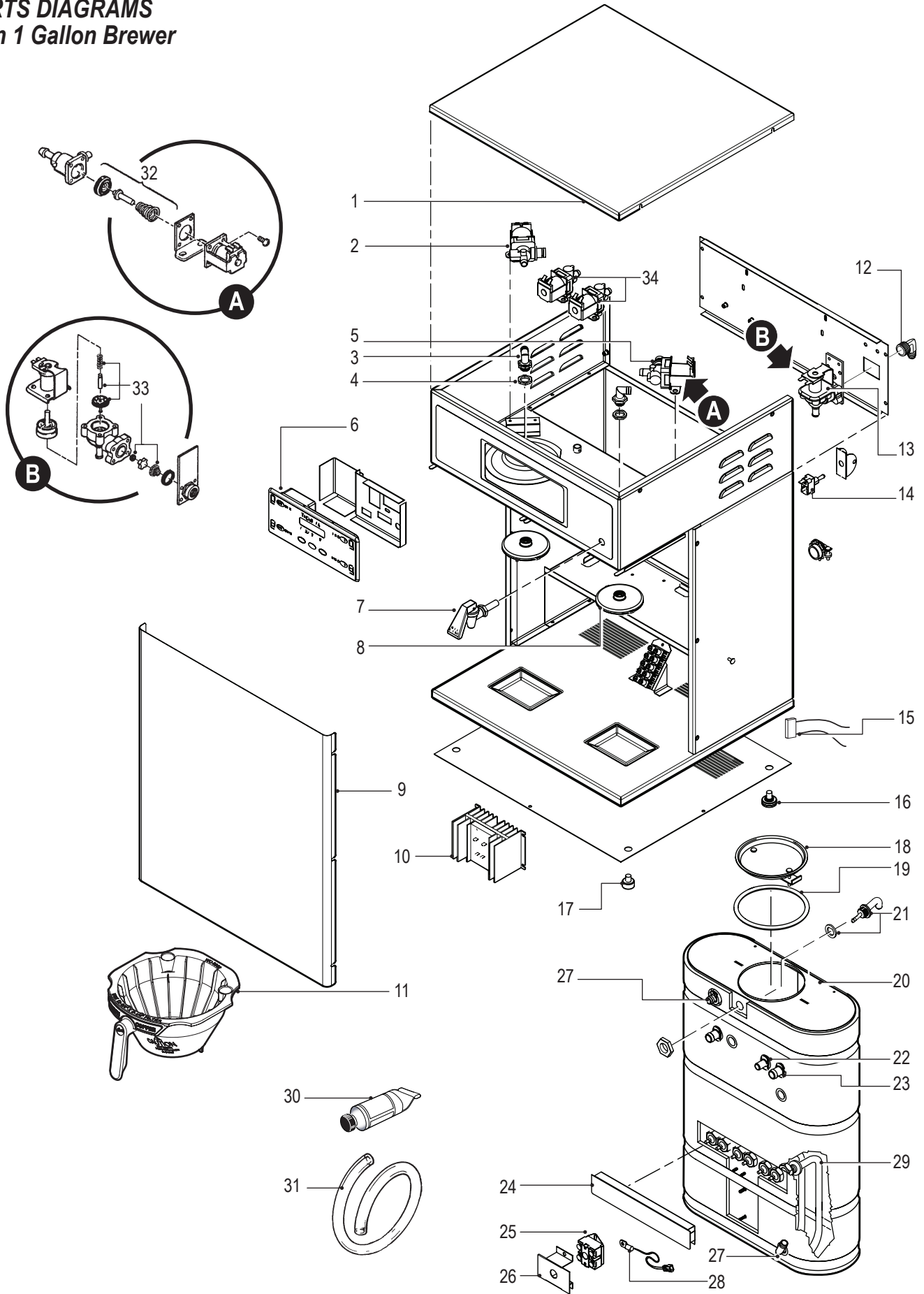

PARTS LIST TP1T & TP1TT

Item N ^o	Part N ^o	Description
1	WC-5421	COVER, TOP
2	WC-37121*	VALVE, LIQUID DISPENSING LEFT 120VAC
3	WC-2977-101	FITTING, SPRAYHEAD ULTEM
4	WC-4212-02*	NUT, 5/8-18 JAM ULTEM
5	WC-37122*	VALVE, DUMP 120V 12W RIGHT
6	WC-37231*	KIT, UCM & LABEL
7	WC-1809	FAUCET, HOT WATER W/JAMNUT
7A	WC-1806*	SEAT CUP, FOR WC-1809 (NOT SHOWN)
8	WC-29050	SPRAYHEAD, AMBER ADVANCED FLOW
9	WC-59022	PANEL, FRONT TPS1T
9A	WC-61612	PANEL, FRONT TP1TT
10	WC-8559	RELAY, SOLID STATE 40A W/HEAT SINK
11	WC-37308	KIT, BREW CONE PLASTIC GEM COFFEE LOGO
12	WC-2402	ELBOW, 3/8"FL x 3/8" M. PIPE
13	WC- 847*	VALVE, INLET 2GPM
14	WC- 102*	SWITCH, TOGGLE 125/250 VAC RESISTIVE
15	WC-8591*	CAPACITOR, X2
16	WC-3518	LEG, GLIDE 3/8-16 STUD SCREW

Item N ^o	Part N ^o	Description
17	WC-3503	LEG, 3/8-16 STUD SCREW (NON-GLIDE)
18	WC-37008*	KIT, HEATING TANK LID
19	WC-43067*	GASKET, TANK LID
20	WC-62033	TANK, COMPLETE GEMTS W/ULTEM FTTNGS
21	WC-37278*	KIT, LIQUID LEVEL PROBE GT
22	WC-29048	FITTING, STRAIGHT PLASTIC 8MM
23	WC-2959-101	FITTING, STRAIGHT PLASTIC 12MM
24	WC-4382	GUARD, SHOCK HEATING ELEMENT
25	WC- 522*	THERMOSTAT, HI LIMIT HTR DPST 277V 40A
26	WC-43055	GUARD, SHOCK RESET THERMOSTAT
27	WC-29047	FITTING, ELBOW
28	WC-1438-101*	SENSOR, HEATING TANK
29	WC- 934-04*	ELEMENT, HEATING 2.5KW 220V
30	WC-5231*	COMPOUND, SILICONE 5 OZ TUBE
31	WC-5310*	TUBING, SILICONE, 5/16" I.D. (1 FT.)
32	WC-37132*	KIT, VALVE REPAIR USE ON WC-821
33	WC-3765L*	KIT, VALVE REPAIR USE ON WC-847
34	WC- 844-101*	VALVE, BY-PASS 120V NON-ADJ W/RSTRCTR

* Suggested Parts to Stock

ROUGH-IN DRAWING TP1T & TP1TT

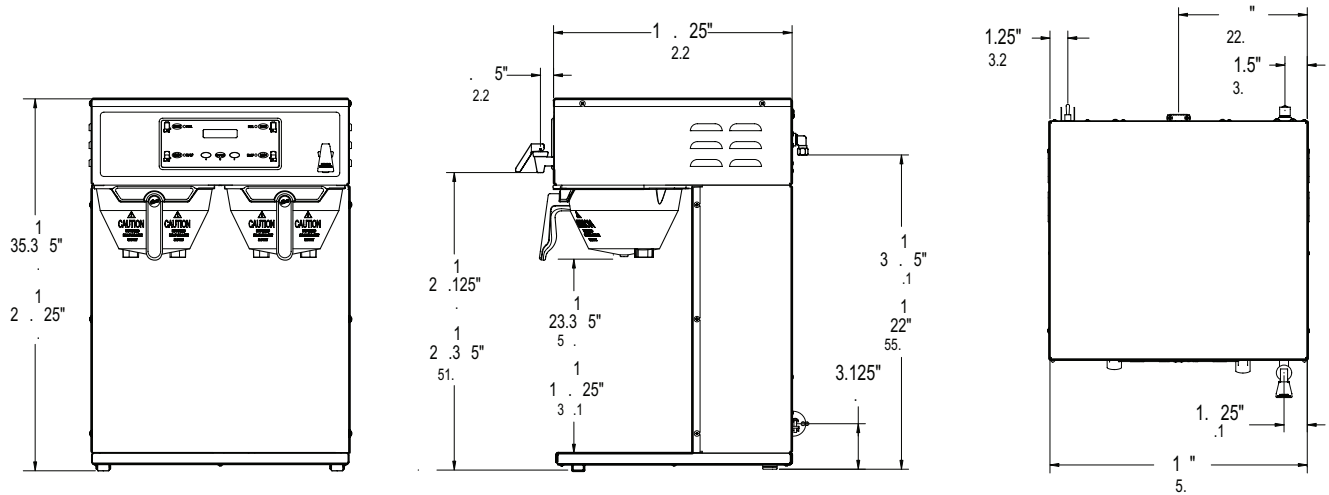

ELECTRICAL SCHEMATIC

TP1T & TP1TT

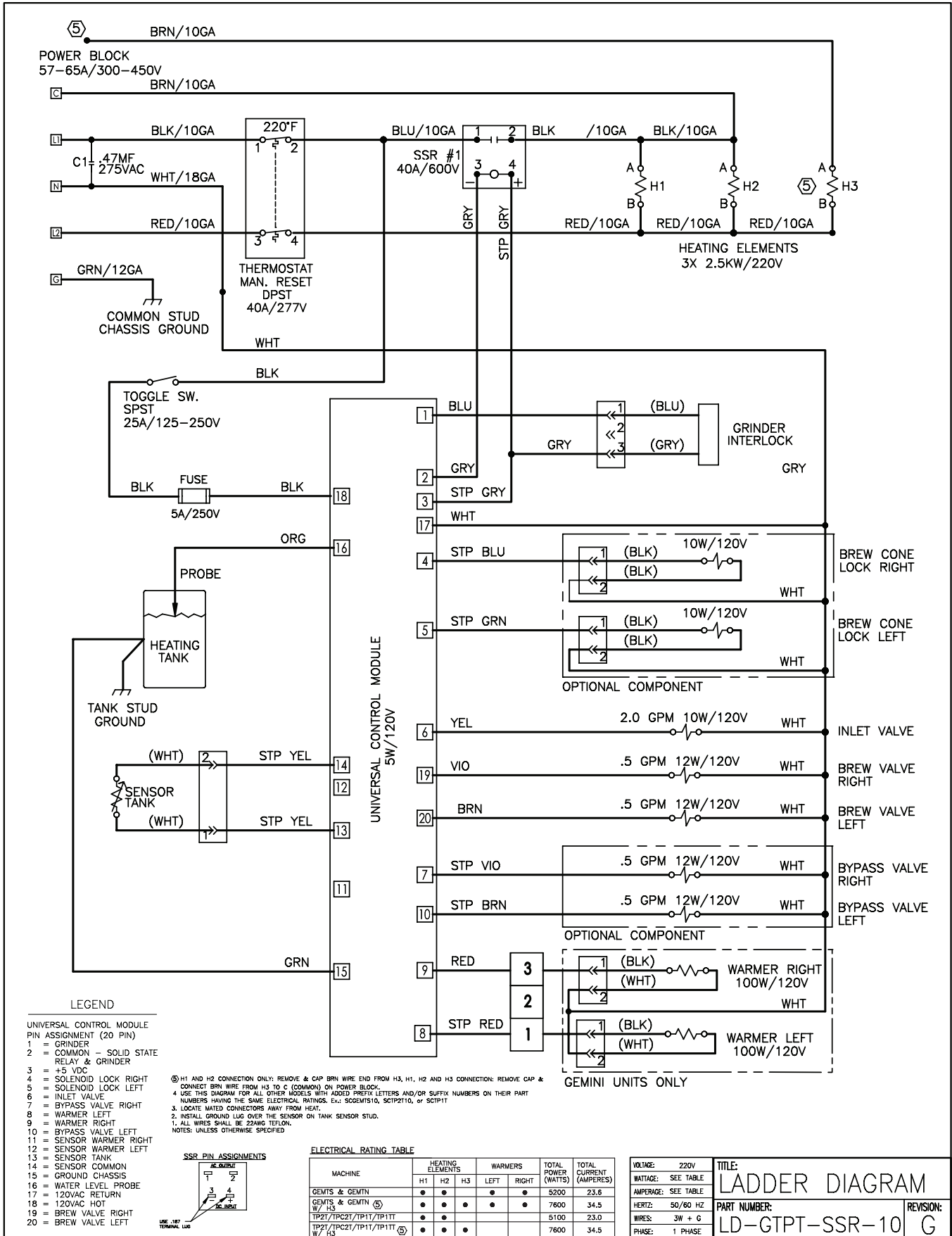

PARTS DIAGRAMS
TP1S & TP1ST

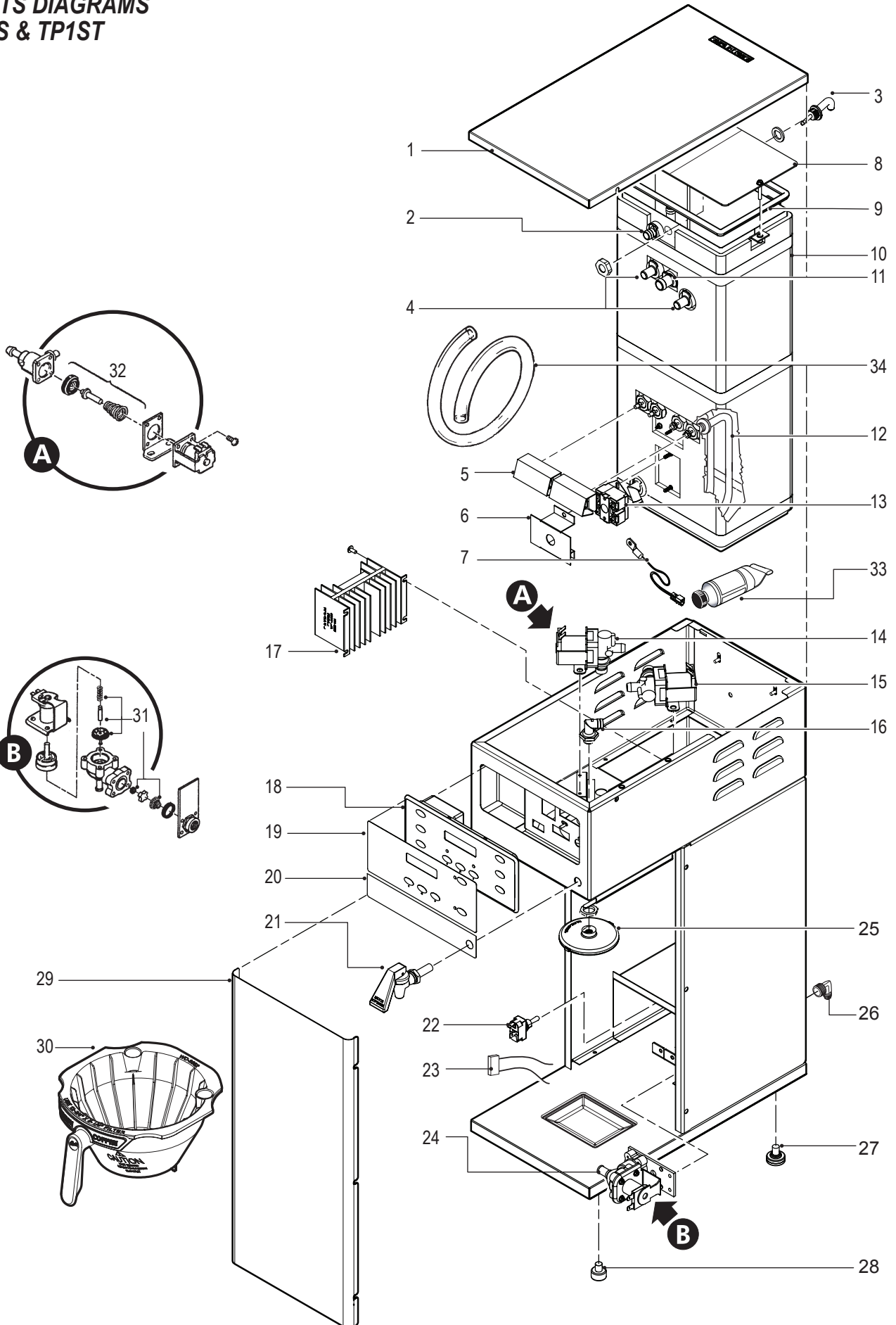

PARTS LIST TP1S & TP1ST

Item N ^o	Part N ^o	Description
1	WC-58117	COVER, TOP
2	WC-29047	ELBOW, OVERFLOW PLASTIC
3	WC-37278*	KIT, LIQUID LEVEL PROBE GT
4	WC-29048	FITTING, STRAIGHT PLASTIC
5	WC-4394	GUARD, SHOCK HEATING ELEMENT
6	WC-43055	GUARD, SHOCK RESET THERMOSTAT
7	WC-1438-101*	SENSOR, HEATING TANK
8	WC-61556	COVER, TANK (FOR UNITS MADE BEFORE 1/2010)
8A	WC-61556-101	LID, TANK TP1S
9	WC-43068*	GASKET, TANK LID (UNITS MADE BEFORE 1/10)
9A	WC-43068-101*	GASKET, TANK LID RECTANGULAR TP1S
10	WC-62037	TANK COMPLETE TP1S/TP1ST
11	WC-2959-101	FITTING, STRAIGHT PLASTIC 12MM
12	WC- 904-04*	ELEMENT, HEATING 1.6KW 120V W/JAM NUT
13	WC- 522 *	THERMOSTAT, HI LIMIT HTR DPST 277V 40A
14	WC- 844-01*	VALVE, BY-PASS, NON-ADJUSTABLE W/RSTRCTR
15	WC-37122*	KIT, DUMP VALVE RIGHT
16	WC-2977-101	FITTING, SPRAYHEAD ULTEM
17	WC-8559	RELAY, SOLID STATE 40A W/HEAT SINK

Item N ^o	Part N ^o	Description
18	WC-37287*	KIT, UCM & OVERLAY 2-BATCH TP1S
19	WC-39580	LABEL, UCM OVERLAY 2-BATCH
20	WC-38439	LABEL, FRONT HOT WATER
21	WC-1809	FAUCET, HOT WATER W/JAMNUT
22	WC- 102*	SWITCH, TOGGLE 125/250 VAC RESISTIVE
23	WC-8591*	CAPACITOR, X2
24	WC- 847*	VALVE, INLET 2GPM
25	WC-29050	SPRAYHEAD, AMBER ADVANCED FLOW
26	WC-2402	ELBOW, 3/8"FL x 3/8" M. PIPE
27	WC-3518	LEG, GLIDE 3/8-16 STUD SCREW
28	WC-3503	LEG, 3/8-16 STUD SCREW (NON-GLIDE)
29	WC-61622	COVER, FRONT SS TP1ST TALL
29A	WC-61551	COVER, FRONT SS TP1S SHORT
30	WC-37308	KIT, BREW CONE PLASTIC GEMINI COFFEE
31	WC-3765L*	KIT, VALVE REPAIR USE ON WC-847
32	WC-37132*	KIT, VALVE REPAIR USE ON WC-844WDR
33	WC-5231*	COMPOUND, SILICONE 5 OZ TUBE
34	WC-5310*	TUBING, SILICONE, 5/16" I.D. (1 FT.)

* Suggested Parts to Stock

ELECTRICAL SCHEMATIC TP1S & TP1ST

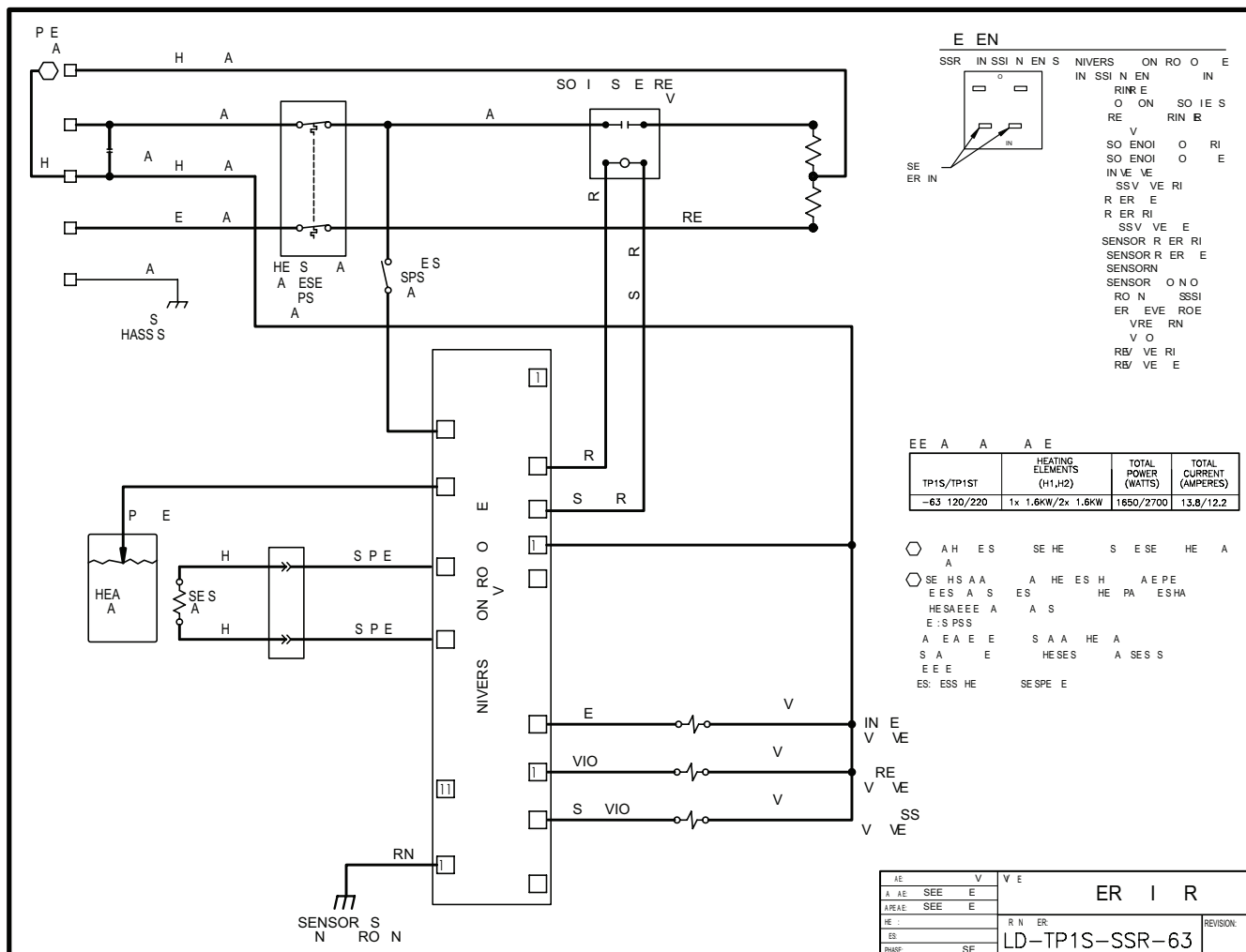

CLEANING

Regular cleaning of the coffee brewer will maintain the highest quality coffee your equipment is capable of producing. Proper cleaning is essential to maintain that fresh, appealing look to your coffee service.

1. First turn off the brewer using the ON/OFF button on the front control panel.
2. Wipe all exterior surfaces with a damp cloth, removing spills and debris.
3. Slide the brewcone out and clean it. Thoroughly wipe sprayhead area with a damp cloth.
4. Wash the brewcone and wire brew basket, if applicable. Use a soft bristled brush for hard to clean areas. Wash both parts with a detergent solution or put these parts through a dishwasher.



CAUTION

Do not use harsh powders or cleansers containing chlorine.

Cleaning and Sanitizing Instructions for TLXG01 Server



CAUTION

- Do not immerse server in water.
- Do not place in server dishwasher.
- Do not use harsh powders or cleansers containing chlorine.
- Do not use a wire brush or pot scourer to clean inside liner.

These cleaning and sanitizing instructions are only a guide line to be used for the cleaning and sanitizing of the TLXG01. Your current in-house cleaning and sanitizing methods may be just as effective.

For cleaning and sanitizing of the TLXG01, the three sink method is recommended. This method consists of a sink of water filled with a detergent and water solution, a fresh water rinse, and a sink filled with an aqueous sanitizing solution. Immerse parts in commercial BarTabs/Sani-Tabs sanitizing solution. The solution must be warm (75°F.) Let the parts soak at least one minute.

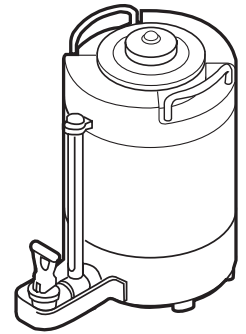

1. Daily, Rinse the unit after use.

- a. Rinse unit with hot water and empty completely.
- b. Fill unit with hot water.
- c. Open unit and empty contents completely.

2. Clean and sanitize the lid assembly.

- a. Remove lid from unit and submerge it in cleaning solution, cleaning thoroughly.
- b. Using the supplied brush, clean inside the filling tube.
- c. Rinse with clean water.
- d. Submerge in sanitizing solution for 5 minutes then air dry completely.

3. Cleaning and sanitizing body assembly.

- a. Completely fill the unit with cleaning solution. With a sponge brush, thoroughly clean inside liner.
- b. Rinse the unit using a fresh water rinse.
- c. Fully fill unit with sanitizing solution. Allow to sit for 5 minutes then drain through the faucet.
- d. Remove faucet and gauge glass from unit and brush out with cleaning solution.
- e. With the faucet removed, clean the silicone elbow fitting (Tank to Faucet Tube). Use the tube brush soaked in cleaning solution, inserted through the faucet shank. Rinse by pouring water from inside the unit, allowing rinse water to flow into a sink until water runs clear.
- f. Wipe outside of unit with clean cloth moistened with cleaning solution.
- g. Place body assembly upside down on rack to thoroughly air dry.

4. Cleaning the faucet parts.

- a. Unscrew the bonnet/handle assembly from the faucet and disassembly removing spring, seat cup and shaft.
- b. Clean and rinse parts. Place in sanitizing solution for 5 minutes, remove and air dry,

5. When all pieces are completely dry reassemble for use.

ROUGH-IN DRAWING
TP1S & TP1ST

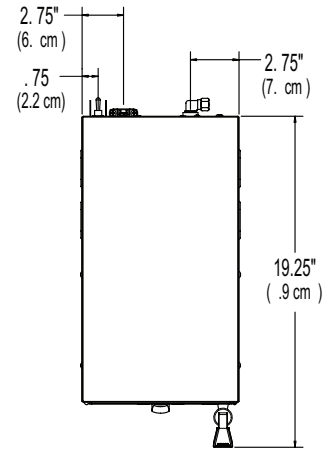
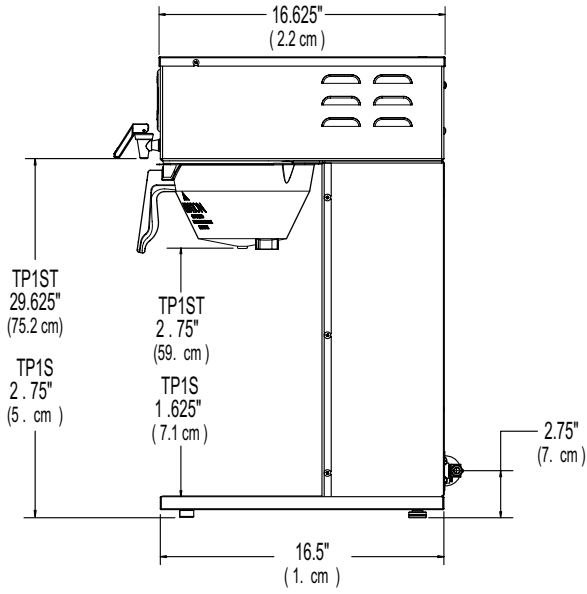
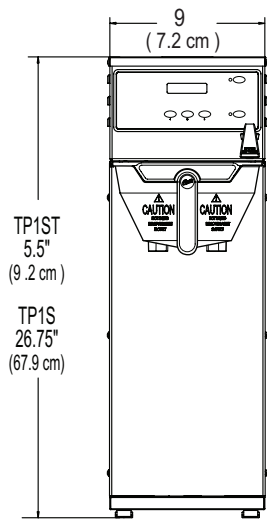

This Page Intentionally Left Blank

Product Warranty Information

The Wilbur Curtis Company certifies that its products are free from defects in material and workmanship under normal use. The following limited warranties and conditions apply:

3 Years, Parts and Labor, from Original Date of Purchase on digital control boards.

2 Years, Parts, from Original Date of Purchase on all other electrical components, fittings and tubing.

1 Year, Labor, from Original Date of Purchase on all electrical components, fittings and tubing.

Additionally, the Wilbur Curtis Company warrants its Grinding Burrs for Forty (40) months from date of purchase or 40,000 pounds of coffee, whichever comes first. Stainless Steel components are warranted for two (2) years from date of purchase against leaking or pitting and replacement parts are warranted for ninety (90) days from date of purchase or for the remainder of the limited warranty period of the equipment in which the component is installed.

All in-warranty service calls must have prior authorization. For Authorization, call the Technical Support Department at 1-800-995-0417. Effective date of this policy is April 1, 2003.

Additional conditions may apply. Go to www.wilburcurtis.com to view the full product warranty information.

CONDITIONS & EXCEPTIONS

The warranty covers original equipment at time of purchase only. The Wilbur Curtis Company, Inc., assumes no responsibility for substitute replacement parts installed on Curtis equipment that have not been purchased from the Wilbur Curtis Company, Inc. The Wilbur Curtis Company will not accept any responsibility if the following conditions are not met. The warranty does not cover and is void under the following circumstances:

- 1) Improper operation of equipment: The equipment must be used for its designed and intended purpose and function.
- 2) Improper installation of equipment: This equipment must be installed by a professional technician and must comply with all local electrical, mechanical and plumbing codes.
- 3) Improper voltage: Equipment must be installed at the voltage stated on the serial plate supplied with this equipment.
- 4) Improper water supply: This includes, but is not limited to, excessive or low water pressure, and inadequate or fluctuating water flow rate.
- 5) Adjustments and cleaning: The resetting of safety thermostats and circuit breakers, programming and temperature adjustments are the responsibility of the equipment owner. The owner is responsible for proper cleaning and regular maintenance of this equipment.
- 6) Damaged in transit: Equipment damaged in transit is the responsibility of the freight company and a claim should be made with the carrier.
- 7) Abuse or neglect (including failure to periodically clean or remove lime accumulations): Manufacturer is not responsible for variation in equipment operation due to excessive lime or local water conditions. The equipment must be maintained according to the manufacturer's recommendations.
- 8) Replacement of items subject to normal use and wear: This shall include, but is not limited to, light bulbs, shear disks, "O" rings, gaskets, silicone tube, canister assemblies, whipper chambers and plates, mixing bowls, agitation assemblies and whipper propellers.
- 9) Repairs and/or Replacements are subject to our decision that the workmanship or parts were faulty and the defects showed up under normal use. All labor shall be performed during regular working hours. Overtime charges are the responsibility of the owner. Charges incurred by delays, waiting time, or operating restrictions that hinder the service technician's ability to perform service is the responsibility of the owner of the equipment. This includes institutional and correctional facilities. The Wilbur Curtis Company will allow up to 100 miles, round trip, per in-warranty service call.

RETURN MERCHANDISE AUTHORIZATION: All claims under this warranty must be submitted to the Wilbur Curtis Company Technical Support Department prior to performing any repair work or return of this equipment to the factory. All returned equipment must be repackaged properly in the original carton. No units will be accepted if they are damaged in transit due to improper packaging. **NO UNITS OR PARTS WILL BE ACCEPTED WITHOUT A RETURN MERCHANDISE AUTHORIZATION (RMA). RMA NUMBER MUST BE MARKED ON THE CARTON OR SHIPPING LABEL.** All in-warranty service calls must be performed by an authorized service agent. Call the Wilbur Curtis Technical Support Department to find an agent near you.



WILBUR CURTIS CO., INC.

6913 Acco St., Montebello, CA 90640-5403 USA

Phone: 800/421-6150 ♦ Fax: 323-837-2410

♦ Technical Support Phone: 800/995-0417 (M-F 5:30A - 4:00P PST) ♦ E-Mail: techsupport@wilburcurtis.com

♦ Web Site: www.wilburcurtis.com

FOR THE LATEST SPECIFICATION INFORMATION GO TO WWW.WILBURCURTIS.COM