



Quality Refrigeration

# OWNER'S MANUAL



***Solid or Glass Door & Drawer Models  
Compact Undercounter Refrigerators & Freezers  
Compact Raised & Flat Cover Prep Tables***

*\*For Legacy UHT, ULT, UPT, & UST Models*

4401 Blue Mound Road Fort Worth, Texas 76106 (USA)  
Phone: 800.825.8220 | Service Fax: 817.740.6757 | E-mail: [service@traulsen.com](mailto:service@traulsen.com) | Website: [traulsen.com](http://traulsen.com)

Hours Of Operation: Monday - Friday 7:30 a.m. - 4:30 p.m. (CST)

# TABLE OF CONTENTS

## I. THE SERIAL TAG

a - Reading the Serial Tag Page 1

## II. RECEIPT INSPECTION

Page 2

## III. INSTALLATION

a - Location Page 2  
 b - Packaging Page 2  
 c - Installing/Adjusting Legs or Casters Page 2  
 d - Shelf Clips for Door Models Page 3  
 e - Cord & Plug Page 3  
 f - Power Supply Page 3  
 g - Clearance Page 3  
 h - Cutting Board Assembly: UPT/UST Page 3  
 i - Installing the Stainless Steel Top: UHT Page 3

## IV. OPERATION & CONTROL

a - Prestart Checks Page 4  
 b - Information Menu Page 4  
 c - Adjusting Cabinet Setpoint Page 4  
 d - Initiating a Defrost Page 4  
 e - Configuration Parameters Page 5  
 f - Technical Data Page 5  
 g - Components and Wiring Diagram Page 9  
 h - Refrigerating Product Page 10  
 i - Pans & Divider Bars - Top Rail Page 10  
 j - Pans & Divider Bars - Drawers Page 10

## V. CARE & MAINTENANCE

a - Cleaning the Exterior Page 10  
 b - Cleaning the Interior Page 10  
 c - Cleaning the Condenser Coil Page 10  
 d - Condensate Removal System Care Page 10

## VI. OTHER

a - Service Information Page 11  
 b - Ventilated Area Page 11  
 c - Cabling Page 11  
 d - Detection of Flammable Refrigerants Page 11  
 e - Removal and Evacuation Page 11  
 f - Spare Parts Page 12  
 g - Warranty Registration Page 12

## VII. MISC. OPERATIONS

a - Rehinging the Door Page 12  
 b - Adjusting the Door Page 12  
 c - Door & Drawer Gasket Replacement Page 12  
 d - Preparing for Extended Shutdown Page 12

## VIII. TROUBLE SHOOTING GUIDE

Page 13

## X. NOTES







Page 14

## I. THE SERIAL TAG

The serial tag is a permanently affixed label on which is recorded vital electrical and refrigeration data about your Traulsen product, as well as the model and serial number. This tag is located in the right interior compartment on all standard models.

### I. a - Reading the Serial Tag

- Serial = The permanent ID# of your Traulsen unit
- Model = The model # of your Traulsen unit
- Volts = Voltage
- Hz = Cycle
- PH = Phase
- Total Current = Maximum amp draw
- Minimum Circuit = Minimum circuit ampacity
- Lights = Light wattage
- Heaters = Heater amperage (Hot Food units only)
- Refrigerant = Refrigerant type used & refrigerant charge
- Design Pressure = High & low side operating pressures
- Agency Labels = Designates agency listings

		ITW Food Equipment Group, LLC North American Refrigeration 4401 Blue Mound Rd. Ft. Worth, TX 76106 800-825-8220			
		MODEL: MODELO: MODELE:		UHT27-L	
SERIAL NUMBER:		22D03839		SCAN FOR SERVICE INFO	
REFRIGERANT / REFRIGERANTE / RÉFRIGÉRANT					
SYS1 (REFM):		R-290	3.00 OZ	85.04 g	85.04 g
Hi Press. (PRESH):			400.00 psi	2,757.90 kPa	2,757.90 kPa
Lo Press. (PRESL):			200.00 psi	1,378.95 kPa	1,378.95 kPa
SYS2 (REFA):		NA			
Hi Press. (PRESH):					
Lo Press. (PRESL):					
Input Power (ELIN) - FOR INDOOR USE ONLY					
Voltage		Hertz		Phase	
115		60		1	
Total Amps		7.20			
Device/Part Number: UHT27-L			Device/Part Notes:		
					
Intertek 4004142 <small>California No. 13, 133, 473                  CUL, IN CAN/CSA STD. C22.2 NO. 120</small>		Intertek 4004142 <small>CONFORME TO/CONFORME À</small>			
					
		Intertek EP 5018173		Compact Undercounter Ref/Frz	
COMPONENTS / COMPOSANTES / COMPONENTES					
	1	2	MAX OVER CURRENT PROTECTION (A):		
COMP AMPS:			MIN CIRCUIT IN AMPS:		
COND FAN AMPS:			DOME LIGHT WATTS:		
EVAP FAN AMPS:			DISPLAY LIGHT WATTS:		
CONTROL AMPS:			DOOR HEATER WATTS:		
DEF HEATER WATTS:			B/TMCE HTR WATTS:		
370-60297-00 REV. D 01/15/2024					

## II. RECEIPT INSPECTION

All Traulsen products are factory tested for performance and are free from defects when shipped. The utmost care has been taken in crating this product to protect against damage in transit.

You should carefully inspect your unit for damage during delivery. If damage is detected, you should save all the crating materials and make note on the carrier's Bill of Lading describing the damage. A freight claim should be filed immediately. If damage is subsequently noted during or immediately after installation, contact our customer care team to file a freight claim. There is a fifteen (15) day limit to file freight damage with the carrier. Under no condition may a damaged unit be returned to Traulsen without first obtaining written permission (return authorization). You may contact Hobart/Traulsen customer care at 800-333-7447 to request a return or file a claim.

### System Using R-290 Refrigerant (Propane)

Traulsen has selected propane as the refrigerant for many of their products.

In addition to its low global warming potential and impact on the environment, propane is an ideal refrigerant. It is a flammable refrigerant, however, which is why you will see a "flammable refrigerant" sticker applicable products. Traulsen products using propane as the refrigerant are UL approved, and are safe to use in accordance with this Owner's Manual and general industry practices for commercial cooking environments.

Please check with local codes or regulations for any restrictions to products using hydrocarbon refrigerants.

## III. INSTALLATION

### III. a - Location

Select a proper location for your unit, away from extreme heat or cold. Allow enough clearance between the unit and the side wall in order to make use of the stay-open feature at 120° (self-closing feature operates up to 90°). The door(s) must be able to open a minimum of 90° in order to make use of the maximum clear door width.

**NOTE: Do not install the cabinet without legs, casters or front ventilated utility base.**

### III. b - Packaging

All Traulsen units are shipped from the factory bolted to a sturdy wooden pallet and packaged in a durable cardboard container. The carton is attached to the wooden skid with the use of large staples. The should first be removed to avoid scratching the unit when lifting off the crate.

To remove the wooden pallet, first if at all possible, we suggest that the cabinet remain bolted to the pallet during all transportation to the point of final installation. The bolts can be removed with a 5/8" socket wrench by tipping or otherwise raising the unit to allow access to them. Avoid laying the unit on its front, side or back for removal of the pallet.

## III. INSTALLATION (cont'd)

**NOTE: Traulsen does not recommend laying the unit down on its front, side or back. However, if you must, please be certain to allow the unit to remain in an upright position afterwards for 24 hours before plugging it in so that the compressor oils and refrigerant may settle.**

### III. c - Installing/Adjusting Legs or Casters

6" high legs are supplied standard for all Traulsen compact undercounter and prep table units. These are shipped from the factory inside a cardboard box which is secured inside the cabinet. Casters, in lieu of legs, are supplied as an optional accessory for all compact undercounter and prep table models. The casters are "stem" type, and do not require the use of any bolts. When ordered casters are shipped in a separate box.

**WARNING: The cabinet must be blocked and stable before installing legs or casters.**

Raise up and block the cabinet a minimum of 7" from the floor and thread the legs into the threaded holes on the bottom of the cabinet's.

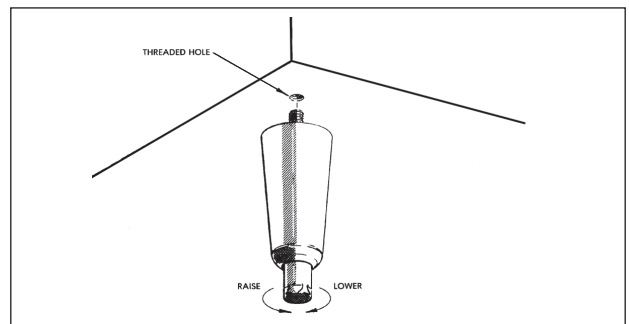

Thread optional casters into the threaded holes on the bottom of the cabinet in the same way. Casters with brakes should be installed at the front.

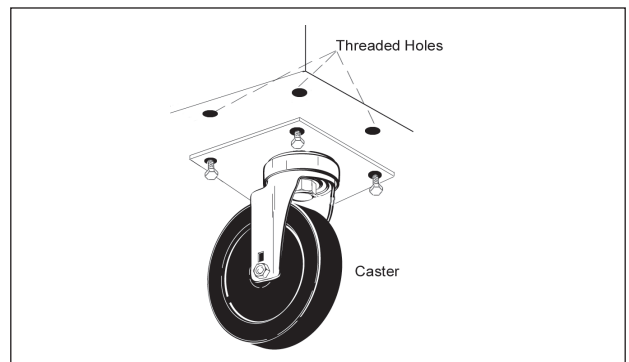

Level the cabinet using a level or pan of water in the bottom of the cabinet. On units with legs, turn the adjustable feet in or out to level the cabinet side-to-side and front-to-back. Units with casters should be placed on level floors.

**NOTE: Traulsen units are not designed to be moved while on legs. If the unit requires moving, a pallet jack or forklift should be used to prevent damage.**

### III. INSTALLATION (cont'd)

#### III. d - Shelf Clips for Door Models

Shelves and shelf clips are shipped with the unit. For each shelf, insert four (4) shelf clips into the pilaster slots at the same height. The shelf clips have a small projection on top which holds the shelf position and prevents it from slipping forward. After installing shelf clips on pilasters, place shelves on clips.

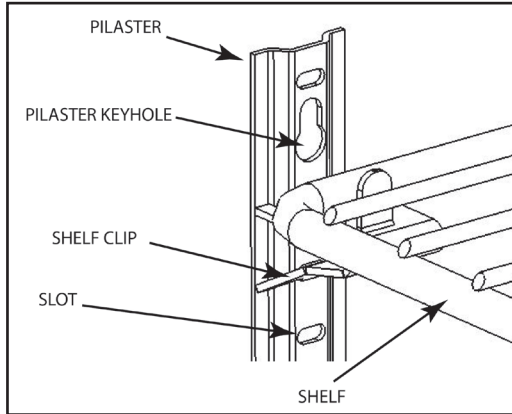

#### III. e - Cord & Plug

All UHT, ULT, UPT & UST models are supplied with a cord and plug attached. It is shipped coiled at the bottom of the cabinet, secured by a nylon strip. For your safety and protection, all units supplied with a cord and plug include a special three-prong grounding plug on the service cord. Select only a dedicated electrical outlet with grounding plug for power source.

**NOTE: Do not under any circumstances, cut or remove the round grounding prong from the plug, or use an extension cord.**

#### III. f - Power Supply

The supply voltage should be checked prior to the connection to be certain that proper voltage for the cabinet wiring is available (refer to the serial tag to determine correct unit voltage, see page 1). Make connections in accordance with local electrical codes. Use qualified electricians.

Use of a separate, dedicated circuit is required. Size wiring to handle indicated load and provide necessary over current protector in circuit (see amperage requirements on the unit's serial tag).

#### III. g - Clearance

It is important for the proper operation and longevity of your Traulsen unit that it have adequate provisions underneath for air supply to the compressor. There are no clearance requirements for the sides, rear or top.

**NOTE: Do not install the cabinet without legs, casters or a front ventilated utility base.**

#### III. h - Cutting Board Assembly: UPT/UST

On sandwich prep tables, the cutting board may require assembly at the site.

Place cutting board on cabinet, properly align & install three (3)

### III. INSTALLATION (cont'd)

screws to secure in place. The cutting board is field reversible, reverse process to reverse cutting board.

**NOTE: The lid(s)/cover(s) are installed at the factory. No assembly required.**

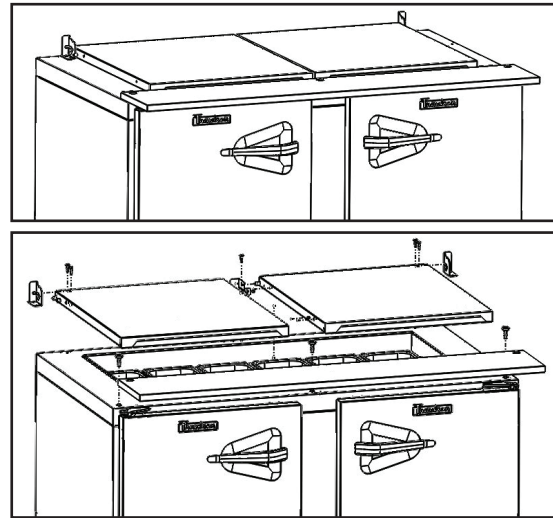

#### III. i - Installing the Stainless Steel Top: UHT

All 27", 32", 48", and 60" wide compact undercounter models can be supplied with an optional stainless steel top. This must be installed on-site, to do so please follow the directions below.

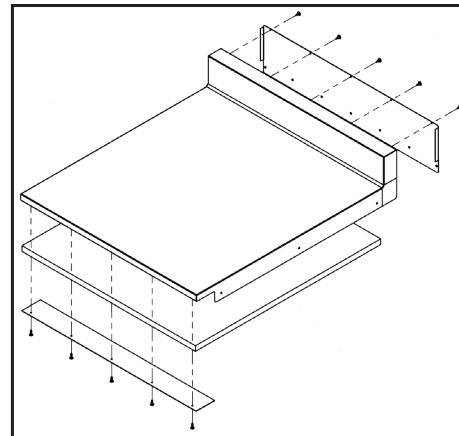

1. Peel-off backing and install foam tape (provided) around entire perimeter of the top of the unit.

2. A flange is assembled underneath at the front of the counter top. This flange has two screw holes. Screw the two 1/4-20x5/8" screws (provided through the holes in this front flange into the threaded holes in the front of the top edge of the unit.

3. Using the five 10-16x1/2" screws provided, screw the bottom of the rear cover plate to the upper rear of the cabinet.

4. If the optional polyethylene cutting board top is provided, there are four threaded pins which screw into the four threaded holes in the work top. The four holes in the polyethylene cutting board top fit around the heads of the four pins.

## IV. OPERATION & CONTROL

### IV. a - Prestart Checks

The compressor must float freely before connecting to electrical power. The compressor motor is provided with rubber vibration isolator mounts (no springs). No bolts need to be loosened. Check all exposed refrigeration lines to make sure they are not dented or kinked. Check for tubing shifts due to shipping that would cause operating noise, wear, or leaks. Check that condenser fan rotates freely.

The refrigeration system should be checked for proper operation before product is stored in the cabinet.

Your new compact is equipped with a digital control, which precisely regulates operation. It is supplied from the factory completely ready for use and is located next to the refrigeration system underneath the cover.



### IV. b - Information Menu

The information available in this menu is:

t1	Instant probe 1 temperature
t2*	Instant probe 2 temperature
cnd**	Compressor working weeks

\* displayed only if enabled (see Configuration Parameters)

\*\* displayed only if ACC > 0

#### Access to menu and information displayed:

- Press and immediately release button **i**.
- With button **▼** or **▲** select the data to be displayed.
- Press button **i** to display value.
- To exit from the menu, press button **✕** or wait for 10 seconds.

#### Initiate Stand-By:

Keeping the button **⏻** pressed for 3 seconds allows the controller to be put on a standby or output control to be resumed (with **SB**=YES only).

#### Locking the Keypad:

The keypad lock avoids undesired, potentially dangerous operations, which might be attempted when the controller is operating in a public place. In the INFO menu, set parameter **LOC** = YES to inhibit all functions of the buttons. To resume normal operation of keypad, adjust setting so that **LOC** = NO.

## IV. OPERATION & CONTROL (cont'd)

### IV. c - Adjusting Cabinet Setpoint

#### Setpoint display and modification:

- Press button **i** for at least a half second to display the setpoint value.
- While keeping the **i** button pressed, use button **▼** or **▲** to set the desired value (adjustment is within the minimum **SPL** and the maximum **SPH** limit).
- When button **i** is released, the new value is stored.

### IV. d - Initiating a Defrost

#### Automatic defrost:

Defrost starts automatically as soon as the time set with parameter **DFT** has elapsed.

- Timed defrost: With **DFM** = TIM defrosts take place at regular intervals when the timer reaches the value of **DFT**. For example, with **DFM** = TIM and **DFT** = 36, a defrost will take place every 6 hours.
- Optimized defrost: With **DFM** = FRO the timer is only increased when the conditions occur for frost to form on the evaporator, until the time set with parameter **DFT** is matched. If the evaporator works at 0°F, defrost frequency depends on the thermal load and climatic conditions. With setpoints much lower than 0°F, defrost frequency mainly depends on the milk cooler operating time.
- Defrost time count backup: At the power-up, if **DFB** = YES, the defrost timer resumes the time count from where it was left off before the power interruption. Vice versa, with **DFB** = NO, the time count re-starts from 0. In stand-by, the accumulated time count is frozen.

#### Manual or remote defrost start:

It's possible to manually start a defrost, by pressing button **⏻** for 2 seconds.

**Defrost type**. Once defrost has started, Compressor and Defrost outputs are controlled according to parameter **DTY**. If **FID** = YES, the evaporator fans are active during defrost.

**Defrost termination**. The actual defrost duration is influenced by a series of parameters.

- Time termination: **T2** = NO and **T3** different from 2EU: the evaporator temperature is not monitored and defrost will last as long as time **DTO**.
- Temperature monitoring of one evaporator: **T2** = YES and **T3** different from 2EU. In this case, if the sensor **T2** measures the temperature **DLI** before the time **DTO** elapses, defrost will be terminated in advance.



## IV. OPERATION & CONTROL (cont'd)

### IV. d - Initiating a Defrost (cont'd)











#### Resuming thermostatic cycle:

When defrost is over, if **DRN** is greater than 0, all outputs will remain off for **DRN** minutes, in order for the ice to melt completely and the resulting water to drain. Moreover, if probe **T2** is active (**T2** = YES), the fans will re-start when the evaporator gets to a temperature lower than **FDD**; Vice versa, if probe **T2** is not active (**T2** = NO) or after defrost has come to an end, such condition does not occur by end of the time **FTO**, after **FTO** minutes have elapsed the fans will be switched on anyway.

Caution: if **DFM** = NON or **C-H** = HEA all defrost functions are inhibited; if **DFT** = 0, automatic defrost functions are excluded.

### IV. e - Configuration Parameters

#### Parameter Configuration:

- To get access to the parameter configuration menu, press button  and  for 5 seconds.
- With button  or  select the parameter to be modified.
- Press button  to display the value.
- By keeping button  pressed, use button  or  to set the desired value.
- When button  is released, the newly programmed value is stored and the following parameter is displayed.
- To exit from the setup, press button  or wait for 30 seconds.

### IV. f - Technical Data

#### Power supply

TRL-002....W 100-240Vac ±10%, 50/60Hz, 3W

#### Relay output max loads (240Vac)

	TRL-002..S/T..-	TRL-002..Q/R..-
Compressor	16A resistive 12 FLA 48 RLA	12A resistive 12 FLA 48 RLA
Evap. Fan	16A resistive 4 FLA 12 RLA	8A resistive 4 FLA 12 RLA
Defrost	16A resistive 4 FLA 12 RLA	16A resistive 4 FLA 12 RLA
Auxiliary loads 1	7A resistive	7A resistive
Auxiliary loads 2	7A resistive	7A resistive

#### Measurement Range

<0.5 within the measurement range

#### Operating Conditions

-10... +50°C; 15%...80% r.H.

#### CE (Approvals and Reference Norms)

EN60730-1; EN60730-2-9; EN55022 (Class B); EN50082-1

## IV. OPERATION & CONTROL (cont'd)

PAR	RANGE	DESCRIPTION
<b>SPL</b>	-58..SPH	Minimum limit for SP setting.
<b>SPH</b>	SPL...180°	Maximum limit for SP setting.
<b>SP</b>	SPL... SPH	Setpoint (value to be maintained in the room).
<b>C-H</b>	REF; HEA	Refrigerating (REF) or Heating (HEA) control mode.
<b>HY0</b>	1...10°	Thermostat OFF -> ON differential.
<b>HY1</b>	0...10°	Thermostat ON -> OFF differential.
<b>CRT</b>	0...30min	Compressor rest time. The output is switched on again after CRT minutes have elapsed since the previous switchover. We recommend to set CRT=03 with HY0<2.0°.
<b>CT1</b>	0...30min	Compressor/Heater output run when probe T1 is faulty. With CT1=0 the output will always remain OFF.
<b>CT2</b>	0...30min	Compressor/Heater output stop when probe T1 is faulty. With CT2=0 and CT1>0 the output will always be ON. Example: CT1=4, CT2= 6: In case of probe T1 failure, the compressor will cycle 4 minutes ON and 6 minutes OFF.
<b>DFM</b>	NON; TIM; FRO CRN	Defrost start mode NON : defrost function is disabled (the following parameter will be FCM). TIM : regular time defrost. FRO : the defrost time count is only increased when the conditions occur for frost to form on the evaporator (optimized time increase). CRN : defrost is based off of compressor run time (time is based off of DAT).
<b>DFT</b>	0...250	Time interval among defrosts in x10 minutes. When this time has elapsed since the last defrost, a new defrost cycle is started. Each number is multiplied by 10 minutes. 0-250 indicates 0-2500 minutes.
<b>DAT</b>	0...100 hours	Frost accumulation timeout.
<b>DFB</b>	NO/YES	Defrost timer backup. With DFB=YES, after a power interruption, the timer resumes the count from where it was left off with ±30 min. approximation. With DFB=NO, after a power interruption, the defrost timer will re-start to count from zero.
<b>DLI</b>	-58...180°	Defrost end temperature.
<b>DMD</b>	0...30min	Minimum defrost duration.
<b>DTO</b>	1...120min	Maximum defrost duration.
<b>DTY</b>	OFF; ELE; GAS	Defrost type OFF: off cycle defrost (Compressor and Heater OFF). ELE: electric defrost (Compressor OFF and Heater ON). GAS: hot gas defrost (Compressor and Heater ON).
<b>DSO</b>	OFF; LO; HI	Defrost start optimization OFF : no optimization. LO : defrost waits until the compressor cut-out. HI : defrost waits until the compressor cut-in.
<b>SOD</b>	0...30 min	Start optimization delay.
<b>DPD</b>	0...240sec	Evaporator pump down. At the beginning of defrost, outputs (determined by DTY) are OFF for DPD seconds.
<b>DRN</b>	0...30min	Pause after defrost (evaporator drain down time).
<b>DDM</b>	RT; LT; SP; DEF	Defrost display mode. During defrost the display will show: RT: the real temperature; LT : the last temperature before defrost; SP : the current setpoint value; DEF : "dEF".
<b>DDY</b>	0...60min	Display delay. The display shows the information selected with parameter DDM during defrost and for DDY minutes after defrost termination.

## IV. OPERATION & CONTROL (cont'd)

PAR	RANGE	DESCRIPTION
<b>FID</b>	NO/YES	Fans active during defrost.
<b>FDD</b>	-58...180°	Evaporator fan re-start temperature after defrost.
<b>FTO</b>	0...120min	Maximum evaporator fan stop after defrost.
<b>FCM</b>	NON; TMP; TIM	Fan mode during thermostatic control. NON : The fans remain ON all the time; TMP : Temperature-based control. The fans are ON when the compressor is ON. When the compressor is turned OFF, the fans remain ON as long as the temperature difference $T_e - T_a$ is greater than FDT. The fans are turned ON again with FDH differential. ( $T_e$ = Evaporator temperature, $T_a$ = Air temperature); TIM : Timed-based control. The fans are ON when the compressor is ON. When the compressor is OFF, the fans switch ON and OFF according to parameters FT1, FT2, FT3
<b>FDT</b>	-12...0°	Evaporator-Air temperature difference for the fans to turn OFF after the compressor has stopped.
<b>FDH</b>	1...12°	Temperature differential for fan re-start.  Example: FDT = -1, FDH=3. In this case, after the compressor has stopped, the fans are OFF when $T_e > T_a - 1$ (FDT), whereas the fans are ON when $T_e < T_a - 4$ (FDT-FDH).
<b>FT1</b>	0...180sec	Fan stop delay after compressor/heater stop. See Fig. 2
<b>FT2</b>	0...180	Timed fan stop in x10 seconds. With FT2=0 the fans remain on all the time.
<b>FT3</b>	0...180	Timed fan run in x10 seconds. With FT3=0, and FT2 > 0, the fans remain off all the time.
<b>ATM</b>	NON; ABS; REL	Alarm threshold management. NON : all temperature alarms are inhibited (the following parameter will be ACC). ABS : the values programmed in ALA and AHA represent the real alarm thresholds. REL : the alarm threshold is obtained by the sum of setpoint, thermostat differential and ALR/AHR.
<b>ALA</b>	-58... 180°	Low temperature alarm threshold.
<b>AHA</b>	-58... 180°	High temperature alarm threshold.
<b>ALR</b>	-12... 0°	Low temperature alarm differential. With ALR=0 the low temperature alarm is excluded.
<b>AHR</b>	0... 12°	High temperature alarm differential. With AHR=0 the high temperature alarm is excluded.
<b>ATI</b>	T1; T2; T3	Probe used for temperature alarm detection.
<b>ATD</b>	0... 120 min	Delay before alarm temperature warning.
<b>ACC</b>	0...52 weeks	Condenser periodic cleaning. When the compressor operation time, expressed in weeks, matches the ACC value programmed, "CL" flashes in the display. With ACC=0 the condenser cleaning warning is disabled and CND disappears from Info Menu.
<b>IISM</b>	NON; MAN; ECO; DI	Switchover mode to second parameter set NON : inhibition to use the second parameter group (the following parameter will be SB). MAN : button switches the two parameter groups over. ECO : automatic switchover to the second parameter group, when ECO conditions are detected. DI : switchover to the second parameter group when DIx input is on.
<b>IISL</b>	-58... IISH	Minimum limit for IISP setting.
<b>IISH</b>	IISL... 180°	Maximum limit for IISP setting.
<b>IISP</b>	IISL... IISH	Setpoint in mode 2.
<b>IIH0</b>	1... 10°	Thermostat OFF->ON differential in mode 2.
<b>IIH1</b>	0... 10°	Thermostat ON->OFF differential in mode 2.
<b>IIDF</b>	0...250	Time interval among defrosts in mode 2 in x10 minutes.
<b>IIFC</b>	NON; TMP; TIM	Fan control in mode 2. See FCM.
<b>ECS</b>	1...5	Controller sensitivity for the automatic switchover from Group I to Group II (1=minimum, 5=maximum).
<b>EPT</b>	0...240 min	Eco pull-down time. Only with IISM=ECO. Group I parameters are used in regulation for at least EPT minutes. See Fig.3
<b>SB</b>	NO/YES	Stand-by button enabling.



## IV. OPERATION & CONTROL (cont'd)

PAR	RANGE	DESCRIPTION
<b>DSM</b>	NON; ALR; STP	Door switch input mode: NON : door switch inhibited ALR : when Dlx=DOR and the digital input is on, an alarm is generated after ADO minutes STP : when Dlx=DOR and the digital input is on, in addition to the alarm, the fans are immediately stopped and the compressor is stopped after CSD minutes.
<b>DAD</b>	0...30 min	Delay before door open alarm warning.
<b>CSD</b>	0...30 min	Compressor/heater stop delay after door has been opened.
<b>D10</b>	NON; DOR; ALR; IISM; RDS	DI1 digital input operation NON : digital input 1 not active. DOR : door input. ALR : when the input is on, an alarm is generated (if AHM=STP, the compressor is stopped and the defrosts are suspended). IISM : when the input is on, the controller will use group 2 parameters. RDS : when the input is on, a defrost is started (remote control).
<b>D1A</b>	OPN; CLS.	DI1 digital input activation. OPN : on open CLS : on close
<b>D20</b>	See D10	DI2 digital input operation. See D10.
<b>D2A</b>	OPN; CLS.	DI2 digital input activation. OPN : on open CLS : on close
<b>PSL</b>	-58...158	Minimum setpoint adjusted via potentiometer.
<b>PSR</b>	0...15	Range of setpoint adjusted via potentiometer.
<b>LSM</b>	NON; MAN; ECO; DI1; DI2; DI3.	Light control mode NON : light output not controlled. MAN : light output controlled through button (if OAx=LGT). ECO : lights activated/deactivated following the ECO state. Dlx : lights activated/deactivated following the Dlx state.
<b>LSA</b>	OPN; CLS	Light activation (only with LSM=ECO or LSM=Dlx). OPN : lights on with Dlx open or ECO mode deactivated. CLS : lights on with Dlx closed or ECO mode activated.
<b>OT1</b>	0...600 sec	Activation time of OA1
<b>OT2</b>	0...600 sec	Pause between OA1 activation
<b>OA1</b>	NON; LGT; 0-1; 2CU; 2EU; ALO; ALC	AUX 1 output operation NON : output disabled (always off). LGT : output enabled for light control. 0-1 : the relay contacts follow the on/standby state of controller. 2CU : output programmed for the control of an auxiliary compressor. 2EU : output enabled for the control of the electrical defrost of a second evaporator. ALO : contacts open when an alarm condition occurs. ALC : contacts make when an alarm condition occurs.
<b>2CD</b>	0...120 sec	Auxiliary compressor start delay. If OAx=2CU the auxiliary output is switched on with a delay of 2CD seconds after the main compressor has cut-in. Both compressors are turned off at the same time.
<b>OS1</b>	-12.5..12.5°	Probe T1 offset.
<b>T2</b>	NO/YES	Probe T2 enabling (evaporator).
<b>OS2</b>	-12.5..12.5°	Probe T2 offset.
<b>T3</b>	NON; DSP; CND; 2EU	Auxiliary probe T3 operation NON : probe T3 not fitted. DSP : temperature T3 to be displayed. CND : condenser temperature measurement. 2EU : second evaporator temperature measurement.

## IV. OPERATION & CONTROL (cont'd)

PAR	RANGE	DESCRIPTION
OS3	-12.5..12.5°	Probe 3 offset.
AHM	NON; ALR; STP;	Operation in case of high condenser alarm NON : high condenser alarm inhibited. ALR : in case of alarm, "HC" flashes in the display and the buzzer is switched on. STP : in addition to the alarm symbols displayed, the compressor is stopped and defrosts are suspended.
AHT	-50...110°	Condensation temperature alarm (referred to T3 probe).
TLD	1...30 min	Delay for minimum temperature (TLO) and maximum temperature (THI) logging.
TDS	T1; 1-2; T3	Selects the temperature probe to be displayed. T1 : probe T1 1-2 : the AVG-weighted average between T1 and T2 T3 : probe T3
AVG	0...100%	The relative weight of T2 on T1 (if TDS = 1-2) Example 1: T1 = -5°, T2 = -20°, AVG = 100%. The displayed temperature will be -20° (T1 has no effect) Example 2: T1 = -5°, T2 = -20°, AVG = 60%. The displayed temperature will be -14.
SCL	1°C; 2°C; °F	Readout scale. 1°C : measuring range -50...110°C (0.1°C resolution within -9.9 ÷ 19.9°C interval, 1°C outside) 2°C : measuring range -50 ... 110°C °F : measuring range -55 ... 180°F
SIM	0...100	Display slowdown.
ADR	1...255	TRL-002 address for PC communication.
NPR	0...1	Setup programmed.
STT	0...255	Setup traceability.

### IV. g - Components and Wiring Diagram



#### Indications:

- Thermostat output
- Fan output
- Defrost output
- Activation of 2<sup>nd</sup> parameter set
- Alarm
- Manual activation / Increase button
- Exit / Stand-by button

### Control Wiring Diagram:

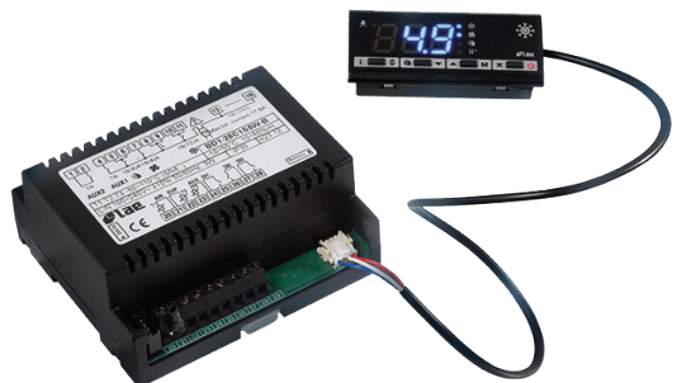
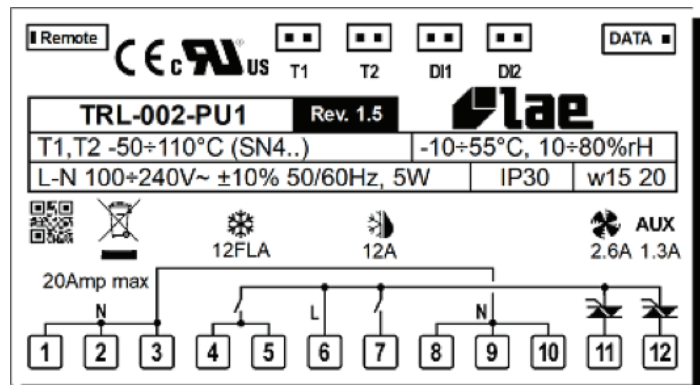

## IV. OPERATION & CONTROL (cont'd)

### IV. h - Refrigerating Product

A thermometer is provided inside all UHT, ULT, UPT & UST models. Allow the cabinet to reach normal operating temperature before loading.

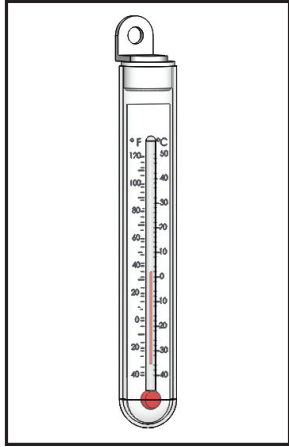

UHT, ULT, UPT & UST Series will satisfactorily refrigerate an assorted load of food items. Allow space between articles to permit free air circulation. Do not overload at any one time with warm food products and expect immediate results. A certain amount of time is required to remove heat from items before operating temperatures can be attained. The system is designed for storage of refrigerated or frozen product.

Opening the door or drawer will increase the temperature in the cabinet and will require a certain amount of time to recover. Also after peak service periods or after warm product is loaded the refrigerator will require a certain amount of time for the temperature to return to the normal operating range.

### IV. i - Pans & Divider Bars - Top Rail

Sandwich prep table models are provided with 1/6 size plastic pans and metal divider bars. When (18) 1/6 size pans are ordered, (4) standard and (1) wide pan divider/supports are provided to achieve appropriate pan separation. When (24) 1/6 size pans are ordered, (6) standard and (1) wide pan divider/supports are provided to achieve appropriate pan separation. All other arrangements use all standard-width pan divider bars.

### IV. j - Pans & Divider Bars - Drawers

Drawer models are provided with metal divider bars standard. All 27" wide models are supplied with (2) bars, 32" wide models are supplied with (2) narrow bars and (1) wide bar, and 60" wide models are supplied with (2) bars and (1) hook divider bar, per drawer.

## V. CARE AND MAINTENANCE

**WARNING: DISCONNECT ELECTRICAL POWER SUPPLY BEFORE CLEANING ANY PARTS OF THE UNIT.**

### V. a - Cleaning the Exterior

Exterior stainless steel should be cleaned with warm water, mild soap and a soft cloth. Apply with a dampened cloth and wipe in the direction of the metal grain.

Avoid the use of strong detergents and gritty, abrasive cleaners as they may tend to mar and scratch the surface. DO NOT use cleaners containing chlorine, this may promote corrosion of the stainless steel.

### V. b - Cleaning the Interior

For cleaning the interior, the use of baking soda as described in section V. a is recommended. Use on breaker strips as well as door and drawer gaskets.

All door models' interior fittings are removable without tools to facilitate cleaning.

Depending on the level of cleaning, drawer models' interior fittings may require a tool to facilitate cleaning. The drawer frame may be removed without tools by simply pulling out and upward. For deeper cleaning the back panel will require a Phillips screwdriver to be removed.

For additional deeper cleaning you may also remove the air duct by removing the thumb screws and rotating them in counter-clockwise motion.

### V. c - Cleaning the Condenser Coil

Check the condenser coil periodically. The operating environment will affect the required frequency of cleaning. Air must be able to freely circulate through the condenser. This surface must be kept free of dirt and grease for proper system operation. Remove the lower rear panel on the rear of the equipment cabinet. Carefully clean dirt and lint from the condenser coil using a vacuum cleaner or soft brush; DO NOT use a wire brush. Replace the lower rear panel. Reconnect electrical supply.

### V. d - Condensate Removal System Care

The evaporator coil, condensate loop and condensate pan, when needed, can all be flushed with fresh water by a qualified service technician. This should be part of any routine maintenance program and can prolong the life of the equipment.

Condensate removal is provided by evaporation at the lower rear portion of the equipment cabinet and does not need a drain. Periodic cleaning of the condensate removal box, remove the lower panel at the rear of the equipment cabinet. Clean the condensate removal box by wiping it out with a clean damp cloth, using care with the condensate loop inside. Replace the lower rear panel. Reconnect electrical power supply.

## VI. OTHER

### VI. a - Service Information

Before calling for service, please check the following:

- Is the electrical cord plugged in?
- Is the fuse OK or circuit breaker on?
- Is the power switch "ON"?

If after checking the above items and the unit is still not operating properly, please contact an authorized Traulsen service agent. You may obtain the name of a service agent from the Service tab of our website: [www.traulsen.com](http://www.traulsen.com).

If service is not satisfactory, please contact our in-house service department at: **Traulsen**

**4401 Blue Mound Road Fort Worth, TX 76106  
(800) 825-8220**

Traulsen reserves the right to change specifications or discontinue models without notice.



This appliance is marked with the ISO 7010-W021 warning label to indicate the presence of FLAMMABLE REFRIGERANTS. Prior to beginning work on systems containing FLAMMABLE REFRIGERANTS, safety checks are necessary to ensure that the risk of ignition is minimized.

### VI. b - Ventilated Area

Ensure that the area is in the open or that it is adequately ventilated before breaking into the system or conducting any hot work. A degree of ventilation shall continue during the period that the work is carried out. The ventilation should safely disperse any released refrigerant and preferably expel it externally into the atmosphere.

### VI. c - Cabling

Check that cabling will not be subject to wear, corrosion, excessive pressure, vibration, sharp edges, or any other adverse environmental effects. The check shall also take into account the effects of aging or continual vibration from sources such as compressors or fans.

### VI. d - Detection of Flammable Refrigerants

Under no circumstances shall potential sources of ignition be used in the searching for or detection of refrigerant leaks. A halide torch (or any other detector using a naked flame) shall not be used.

The following leak detection methods are deemed acceptable for all refrigerant systems. Electronic leak detectors may be used to detect refrigerant leaks but, in the case of FLAMMABLE REFRIGERANTS, the sensitivity might not be adequate, or might need recalibrating. (Detection equipment shall be calibrated in a refrigerant-free area.) Ensure that the detector is not a potential source of ignition and is suitable for the refrigerant used.

## VI. OTHER (cont'd)

### VI. d - Detection of Flammable Refrigerants (cont'd)

Leak detection equipment shall be set at a percentage of the LFL of the refrigerant and shall be calibrated to the refrigerant employed, and the appropriate percentage of gas (25 % maximum) is confirmed.

Leak detection fluids are also suitable for use with most refrigerants but the use of detergents containing chlorine shall be avoided as the chlorine can react with the refrigerant and corrode the copper pipe-work.

**NOTE:** Examples of leak detection fluids are

- bubble method
- fluorescent method agents

If a leak is suspected, all naked flames shall be removed/extinguished.

If a leakage of refrigerant is found which requires brazing, all of the refrigerant shall be recovered from the system, or isolated (by means of shut off valves) in a part of the system remote from the leak. Removal of refrigerant shall be according to Section VI. e below.

### VI. e - Removal and Evacuation

When breaking into the refrigerant circuit to make repairs- or for any other purpose - conventional procedures shall be used. However, for flammable refrigerants it is important that best practice be followed, since flammability is a consideration. The following procedure shall be adhered to:

- a) safely remove refrigerant following local and national regulations;
- b) purge the circuit with inert gas;
- c) evacuate
- d) purge with inert gas;
- e) open the circuit by cutting or brazing.

The refrigerant charge shall be recovered into the correct recovery cylinders if venting is not allowed by local and national codes. For appliances containing flammable refrigerants, the system shall be purged with oxygen-free nitrogen to render the appliance safe for flammable refrigerants. This process might need to be repeated several times. Compressed air or oxygen shall not be used for purging refrigerant systems.

For appliances containing flammable refrigerants, purging shall be achieved by breaking the vacuum in the system with oxygen-free nitrogen and continuing to fill until the working pressure is achieved, then venting to atmosphere, and finally pulling down to a vacuum. This process shall be repeated until no refrigerant is within the system (optional for A2L). When the final oxygen-free nitrogen charge is used, the system shall be vented down to atmospheric pressure to enable work to take place.

Ensure that the outlet for the vacuum pump is not close to any potential ignition sources and that ventilation is available.



## VI. OTHER (cont'd)

### VI. f - Spare Parts

Spare or replacement parts may be obtained through a parts supplier or one of our authorized service agents (see page 17-18 for parts listing). A list of authorized service agents is posted on our company's official website Service tab at [www.traulsen.com](http://www.traulsen.com).

### VI. g - Warranty Registration

The warranty for your new Traulsen unit may be registered with us by completing warranty information online, via our website [www.traulsen.com](http://www.traulsen.com) click on Service Tab or calling us direct at 800-825-8220.

## VII. MISC. OPERATIONS

### VII. a - Rehinging the Door

The door(s) on all UHT, ULT, UPT & UST models can be easily rehinged in the field. To begin, open the door to its maximum position. Support the non-hinged end of the door so minimum movement occurs when the bolts from the lower hinge plate are removed. Remove the lower hinge plate and then the door from the top hinge bracket. The hinge plate pin and plastic bushing will remain in the top hinge plate.

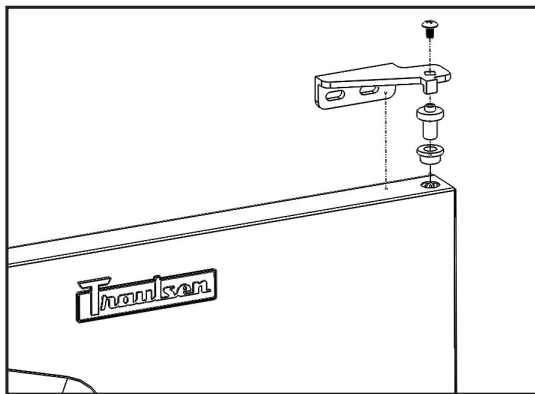

Lay the door down on a padded flat surface while being careful not to allow the lower hinge plate and mechanism stem to slide out the bottom of the door.

**NOTE:** The lower hinge plate is under spring tension. Grasp the lower hinge plate while keeping a firm grip on the plate, carefully slide it out the bottom of the door just far enough to allow the plate to rotate to a full 360°. Unwind the tension of the spring by carefully allowing the hinge plate to rotate a full 360° several times.

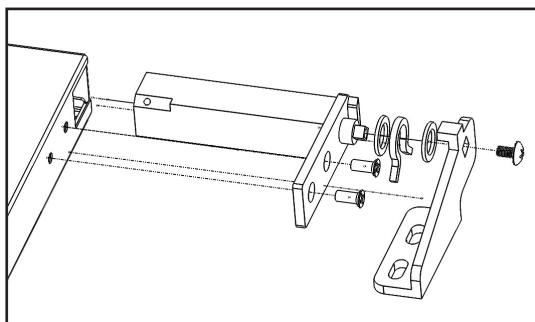

Slide the hinge plate and hinge mechanism stem out the bottom of the door.

## VII. MISC. OPERATIONS (cont'd)

**NOTE:** Remove the brass bushing from the bottom of the door only if spring replacement is necessary. Both the spring and bushing will need to be new parts.

**NOTE:** When installing, make sure the lower hinge plate and hinge mechanism stem are rotated no more than six (6) full turns while applying tension to the spring.

To reinstall the door, position the lower hinge plate into the position of being open 90° to the cabinet. Place the top hinge plate in the hole in the top of the door and support the other end of the door for minimal movement. Start the bolts in the lower hinge plate and tighten the bolts enough to hold the door in place. Remove the block from under the end of the door. Adjust the door.

### VII. b - Adjusting the Door

Occasionally the door (s) may require alignment adjustment. To do so, first open the door and loosen the hinge plate screws enough to move the hinges if desired, but the door is held in place. Center the door in the opening. Next, level the top hinge plate and tighten the screws. Finally, level the lower hinge plate and tighten the screws.

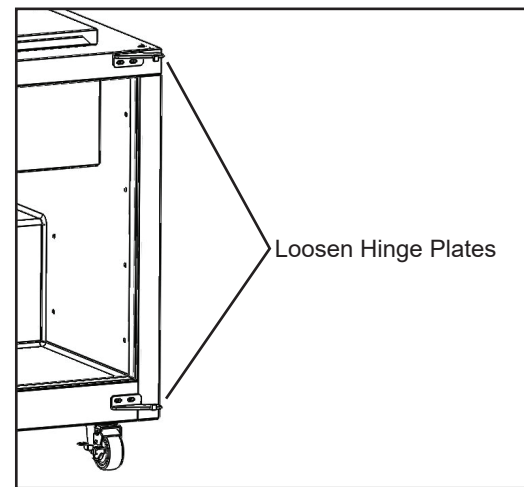

### VII. c - Door & Drawer Gasket Replacement

Remove the old gasket by pulling it out from the gasket retainer. Next, install the four corners of the new gasket by pushing straight in on the gasket until it is hooked behind the gasket retainer. Be careful not to stretch the gasket as it will not return to its original length. Starting at the center of one edge, push the gasket straight in until it is hooked behind the gasket retainer. Proceeding from this point out to the corners, continue pushing the gasket straight into the gasket retainer. Proceed doing the same to each of the remaining edges until the gasket is completely installed.

### VII. d - Preparing for Extended Shutdown

If the refrigerator is not to be used for an extended period of time, disconnect the electrical power supply and open the doors. As soon as the cabinet has warmed up to room temperature, wipe out the interior. Leave the doors open and check again to make sure that no moisture has collected on any parts. To restart refrigerator, follow instructions under sections **III. INSTALLATION** and **IV. OPERATION AND CONTROL**.



## VIII. TROUBLE SHOOTING GUIDE

PROBLEM	REMEDY
<b>1. Condensing unit fails to start.</b>	<ul style="list-style-type: none"> <li>a. Check if cord has been disconnected.</li> <li>b. Check control temperature setting.</li> </ul>
<b>2. Condensing unit operates for prolonged periods or continuously.</b>	<ul style="list-style-type: none"> <li>a. Are doors closing properly?</li> <li>b. Dirty condenser filter. Clean properly.</li> <li>c. Evaporator coil iced. Needs to defrost.</li> </ul>
<b>3. Food compartment is too warm.</b>	<ul style="list-style-type: none"> <li>a. Check door(s) &amp; gasket(s) for proper seal.</li> <li>b. Check if a large quantity of warm food was recently added or the door or drawer was kept open for a long period of time. Allow adequate time for the cabinet to recover its normal operating temperature.</li> <li>c. Control setting too high, re-adjust per instructions.</li> <li>d. Check that condensing coil is clean.</li> </ul>
<b>4. Food compartment is too cold.</b>	<ul style="list-style-type: none"> <li>a. Check if large quantity of very cold or frozen food has recently been added. Allow adequate time for the cabinet to recover its normal operating temperature.</li> <li>b. Adjust the control to a warmer setting.</li> </ul>
<b>5. Condensation on the exterior surface.</b>	<ul style="list-style-type: none"> <li>a. Check door(s) or drawer(s) alignment and gaskets for proper seal.</li> <li>b. Condensation on the exterior surface of the unit is perfectly normal during periods of high humidity.</li> </ul>
<b>6. Compressor hums but does not start.</b>	<ul style="list-style-type: none"> <li>a. Call for service.</li> </ul>
<b>7. No power to unit.</b>	<ul style="list-style-type: none"> <li>a. Check if cord &amp; plug has been disconnected.</li> <li>b. Check power supply breaker.</li> <li>c. Check ON/OFF switch.</li> </ul>

## X. NOTES



Quality Refrigeration

4401 Blue Mound Road Fort Worth, Texas 76106 (USA)

Phone: 800.825.8220 | Service Fax: 817.740.6757 | E-mail: [service@traulsen.com](mailto:service@traulsen.com) | Website: [traulsen.com](http://traulsen.com)

Form Number: TR35746 | Part Number: 375-60184-00 | Revision Date: 03-2024

Traulsen © All Rights Reserved