

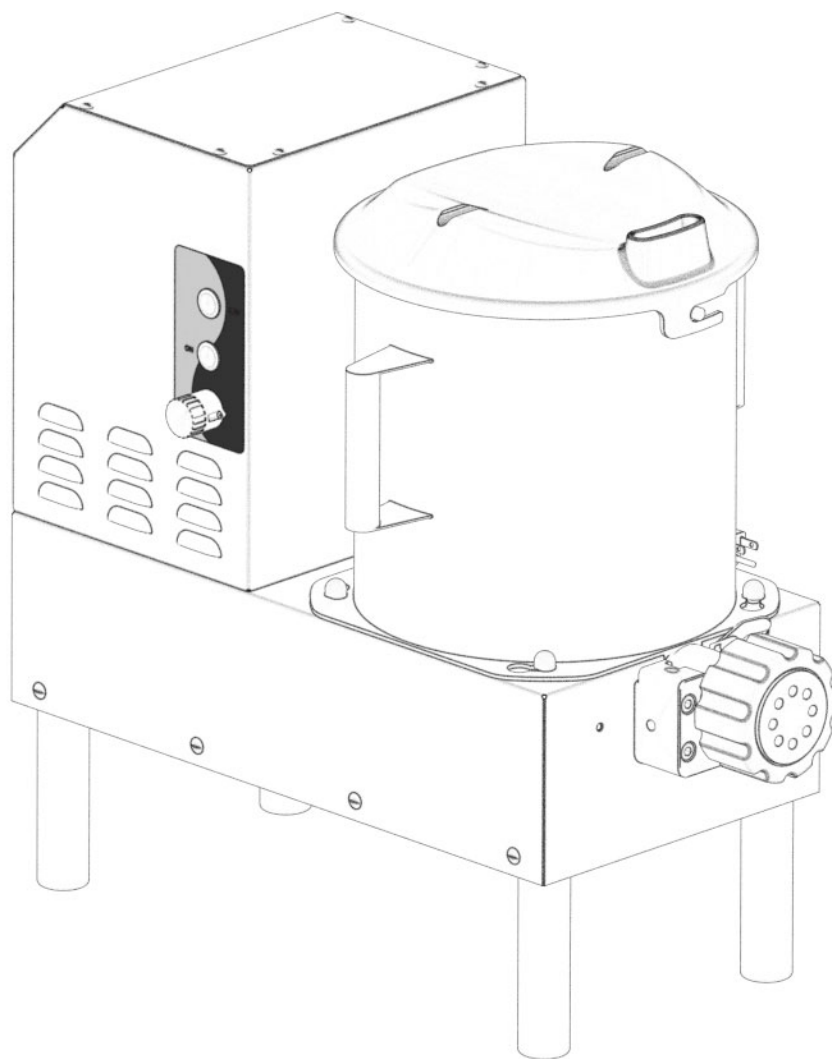

Upasta-01



Ed. 12/2018

Operating and Maintenance Manual

Contents

It is forbidden to use the machine before having carefully read the manual, especially the part that concerns operator safety and health.

1. Preliminary information	3
Notes on the use of this Use and Maintenance Manual	
Manual storage	
Manual consultation	
Intended use	
General safety warnings	
General safety information	
2. Machine transport, handling and warehousing	5
Packing	
Unpacking	
Handling the pasta machine	
3. Use	6
Pasta machine	
Electrical power supply and controls	
4. Safety devices	7
Assembly of parts for pasta production	
Pasta maker die assembly	
5. Technical specifications	9
6. Wiring diagram	10

1. Preliminary information

Notes on the use of this Use and Maintenance Manual

This document must be considered an integral part of the machine it describes and must as such be stored for the entire machine's lifespan.

This document, moreover, must be delivered along with the machine to any other user or owner to whom the machine is transferred.

Manual storage

This document must be used so as not to damage it and must be stored in a suitable place, without humidity or excessive temperature over the entire lifespan of the machine with which it is enclosed.

Manual consultation

The manual is divided into topics. The user can search a particular set of information in the **Contents**.

Certain symbols are used throughout the Manual to allow the user to more easily identify the important notes, as for instance those concerning safety, or to draw the reader's attention to special remarks.

Notes on **safety** are indicated by the following symbol:



Observations that are especially useful to **soundly operate** the machine are indicated by the following symbol:



Prohibition signs that are meant to reduce the possibility of **improper management** of the machine are indicated by the following symbol:



Intended use

The machine described in this Manual is named "Pasta Maker" and has been specifically designed to produce pasta.

The production cycle requires the user to feed appropriate ingredients into the machine poured in through the hopper that are mixed and kneaded by a powered spiral.

When the pasta dough is ready, the user manually opens a hatch and a screw conveyor transports the dough to the kneader.

The manufacturer forbids using the machine for different purposes than those described herein.

Likewise, the label is manufactured in material that can endure bad weather for prolonged time and the information it bears are indelible.

The information displayed includes:

- Manufacturer's full details;
- Serial number;
- Year of manufacture;
- Voltage and frequency;
- Electrical power;
- Weight in Kg.

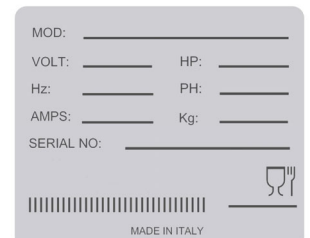

DO NOT REMOVE OR TAMPER WITH THE LABEL ON THE MACHINE.

General safety warnings

All operations performed on the machine, from its use to maintenance to its final demolition, require the presence of suitably qualified staff, in order to limit risks due to inadequate qualification to a minimum.

General safety information

The manufacturer has designed and checked every machine part and their respective function in the minutest detail, to prevent potential hazards.

Nonetheless, given the specific functional features of the machine, below are certain warnings to bear in mind. The conditions that we draw attention to are:

 **THE OPERATOR MUST WEAR CLOTHING AND CARRY PERSONAL BELONGINGS THAT ARE COMPLIANT WITH LEGAL REQUIREMENTS TO ENSURE MACHINE OPERATIONS CAN BE SAFELY CONDUCTED.**

 **BELONGINGS WORN BY THE OPERATOR MUST ONLY BE THOSE THAT ARE INDISPENSABLE AND MUST BE WORN PROPERLY AND STABLY, IN ORDER NOT TO CREATE POTENTIAL HAZARDS OR DANGER FOR THE OPERATOR OR OTHER STAFF ASSIGNED TO THE MACHINE.**

 **DO NOT STICK PROPERTY OR BODY PARTS INSIDE THE MACHINE.**

 **WHEN OPERATING THE MACHINE, THE OPERATOR OR USER MUST APPLY ALL SAFETY STANDARDS REQUIRED BY THE LAWS APPLICABLE IN THE COUNTRY WHERE THE MACHINE IS INSTALLED.**

 **CLEAN THE CONNECTORS AND CABLES WITH COMPRESSED AIR OR USE A DRY CLOTH, IF NECESSARY.**

Furthermore, the user must comply with the following bans over the machine's entire lifespan:

- It is forbidden to open machine guards during its operation.
- It is forbidden to deactivate the safety devices.
- It is forbidden to inspect the machine during its operation.
- It is forbidden to lean on the machine during its operation.
- It is forbidden to sit on top of machine components.
- It is forbidden to use the machine, even only parts of it, for other purposes than those listed in this Manual.
- After cleaning or servicing the machine, reassemble the machine guards as soon as possible.
- It is forbidden to apply other safety devices on the machine unless the manufacturer first grants authorization in writing.
- It is forbidden to use the machine with safety devices or elements other than those recommended by the manufacturer unless the manufacturer first grants authorization in writing.

- Only use the machine with original accessories
- Clean the machine components, panels and controls, with soft cloth and dry.
- It is forbidden to use any type of solvent, like alcohol or gasoline or thinners, to clean any of the surfaces.

- Do not stick your hands, arms or any other body part into or near moving machine parts.
- When inspecting or removing any type of fault and malfunction, be sure to apply all the precautions described in this Manual that are effective in preventing any harm to persons and/or animals and/or property.
- Clothing worn by the operator must be the most appropriate, that is to say, not too loose or too close-fitting, and not have flapping hems and edges.

- Do not wear belts, rings, bracelets and chains. Bundle long hair in a head bayonet.

 **FAILURE TO COMPLY WITH THE ABOVE BANS AUTOMATICALLY IMPLIES THE CANCELLATION OF ANY WARRANTY COVER AND EXEMPTS THE MANUFACTURER OF ALL LIABILITY.**

 **WHEN OPERATING THE MACHINE, THE OPERATOR OR USER MUST APPLY ALL SAFETY STANDARDS REQUIRED BY THE LAWS APPLICABLE IN THE COUNTRY WHERE THE MACHINE IS INSTALLED.**

2. Machine transport, handling and warehousing

Packing

Machine packing consists of a wooden crate. To correctly handle the crate, use a forklift or pallet transporter.

 **ALL TASKS TIED TO MACHINE HANDLING, TRANSPORT AND WAREHOUSING MUST BE CARRIED OUT BY SPECIALIZED PERSONNEL AND IN FULL COMPLIANCE WITH THE LEGISLATION AND STANDARDS APPLICABLE IN THE COUNTRY WHERE THE MACHINE IS INSTALLED.**

 **BEFORE YOU UNPACK THE MACHINE, BE SURE TO CHECK THE PACKING IS INTACT AND INFORM CUSTOMER SERVICE OF ANY UNUSUAL FLAWS.**

Open machine packing

Unpacking

Open the packing and check that the pasta maker is perfectly intact.

Then, remove the pasta maker from its packing and proceed to position it for installation.

 **IF THE MACHINE INCLUDES PACKING, THE OPERATOR MUST STORE IT OVER THE MACHINE'S ENTIRE LIFE CYCLE, IN ORDER TO REUSE IT WHENEVER HANDLING THE MACHINE AFTER ITS INSTALLATION.**

 **IF THE MACHINE DISPLAYS DAMAGE PRIOR TO UNPACKING OR AT ANY RATE PRIOR TO ITS HANDLING, PROMPTLY INFORM CUSTOMER SUPPORT TO RECEIVE CLARIFICATIONS.**

We recommend that you store the packing for future transport tasks.

Handling the pasta machine

 **DURING HANDLING, THE OPERATOR MUST PLACE THE UTMOST ATTENTION TO AVOID THE MACHINE FROM TIPPING OVER.**

 **HANDLE THE MACHINE ONLY WHEN IT IS NOT RUNNING AND IS DISCONNECTED FROM ALL ITS POWER SUPPLIES.**

Positioning and leveling the pasta maker

The machine is capable of operating in outdoor premises at temperatures from +5°C to +35°C and with a humidity of up to 9% without condensation.

After having placed the pasta maker in the desired position, level it with the ground by working on the adjustable supports indicated in the figure.

 **INSTALL THE PASTA MAKER SO THAT IT HAS ENOUGH SPACE AROUND IT FOR THE OPERATOR TO WORK AND ASSEMBLE/DISASSEMBLE THE ACCESSORIES IN TOTAL SAFETY. MOREOVER, PROVIDE SUFFICIENT LIGHTING FOR INSTALLATION.**

3. Use

Pasta machine

The supplied machine consists of the main pasta maker casing and the following parts:

- main parts for pasta dough production
 - (1) dough screw conveyor
 - (2) dough basin
 - (3) drain pipe with open/shut mechanism
 - (4) extruding head
 - (5) out-feed screw conveyor
 - (6) pasta maker die
 - (7) fixing ring nut

Parts for pasta dough:

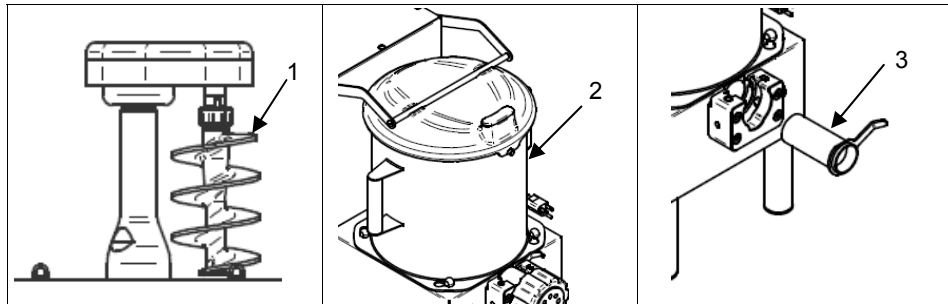

Parts for pasta extrusion:

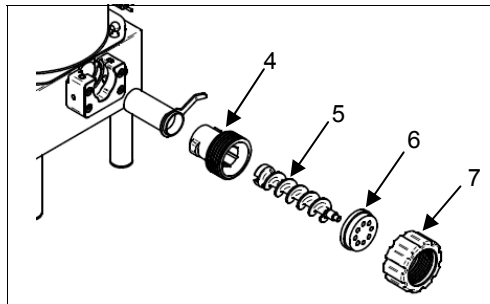

Electrical power supply and controls

The pasta maker plug (1) must be hooked to the electrical power line having the voltage and frequency displayed on the label.

The machine controls are:

- 3) - START button
- 2) - STOP button
- 4) - AUX plug

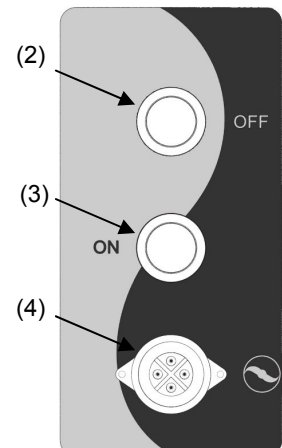
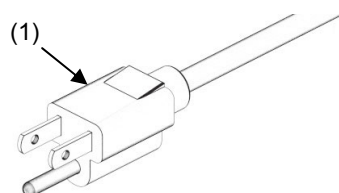

4. Safety devices

The safety sensor (1) is magnetic and controls the presence of the lid (2) where a magnet is fixed. The machine will not start if the lid is not positioned in the right position.

 **WE RECOMMEND THAT YOU CARRY OUT ALL ASSEMBLY, DISASSEMBLY AND CLEANING TASKS ON PARTS WITH THE MACHINE UNPLUGGED FROM ITS SOCKET.**

IT IS FORBIDDEN TO DEACTIVATE THE MICROSWITCH (1).

IT IS FORBIDDEN TO REMOVE THE SAFETY DEVICES.

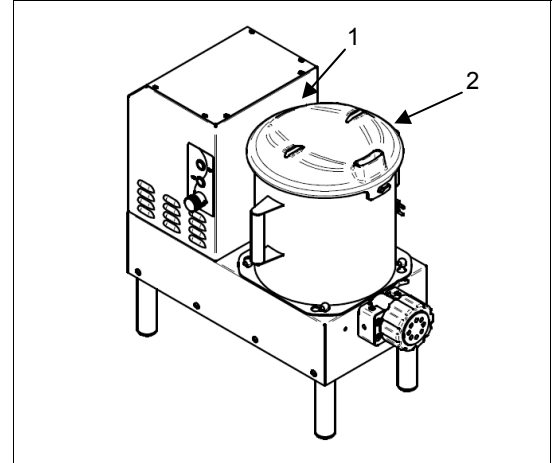

Position of microswitch and safety devices and guards

Assembly of parts for pasta dough production

It is assumed that the pasta maker is "naked", i.e. without any assembled device.

- Assemble the dough spiral (1), fasten the ring nut (2) to the pivot and lock it with the dedicated lever.
- position the tank (3) and turn it clockwise in order to lock it in place using the pins (4).
- fit the pipe (5) to open/shut discharge of the dough and turn it to the letter C (closed)

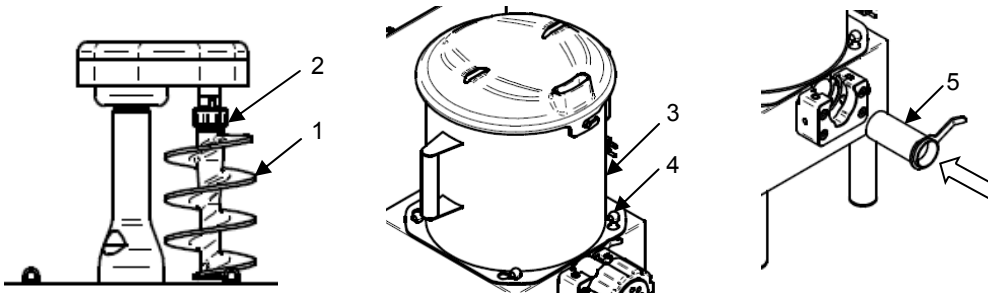

Assembly of parts for pasta extrusion

- insert the extruding head (6), turning and locking it into place with the flywheel (7)
 - push the screw conveyor (8) all the way and turn it so as to be sure its transmission is engaged.
- Now, assemble the following parts, based on the pasta production cycles you wish to perform.

NOTE: to assemble the tank (3) with the devices for discharge already assembled, position the lever (5) of the discharge conduit on C (closed).

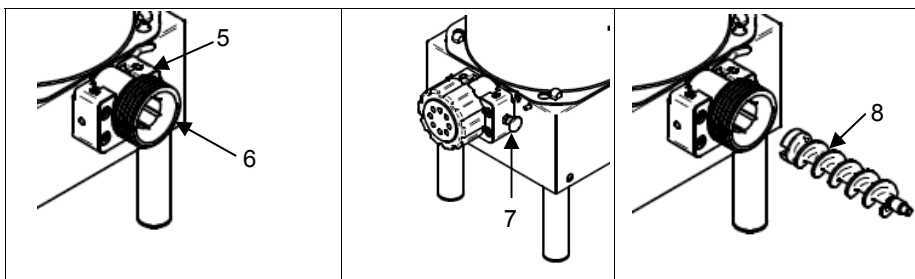

Pasta maker die assembly

After you have assembled the pasta production components, assemble the die, choosing it based on the desired product:

- fit the pasta maker die (1) with the ring nut (2)
- manually tighten the ring nut to the pasta maker as shown in the figure
- further tighten the ring nut to a halt with the relevant wrench (3)

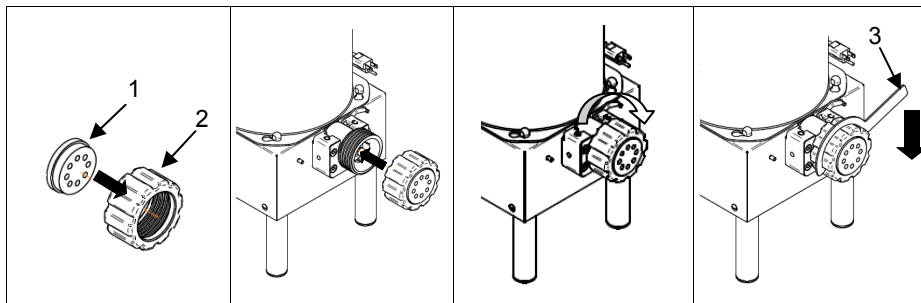

PRODUCTION:

- Check if extrusion gate (4) is closed: handle should be in "C" position.
- Load the tank (3) with max 3 Kg flour
- Close the lid (2) and lock in safety position (1)
- Run the machine pressing START button
- Slowly pour the liquid part (eggs) through the hole on the lid (0,4Kg eggs every Kg of flour: 3 Kg flour = max 1,2 kg eggs)
- Once the eggs are completely poured into the tank, mix until the dough is ready (about 15 min)
- Open the extrusion gate (4) rotating the handle to "O" position
- The machine will start slowly to extrude the requested pasta (5)
- Stop machine pushing OFF button when the dough into the tank is completely extruded

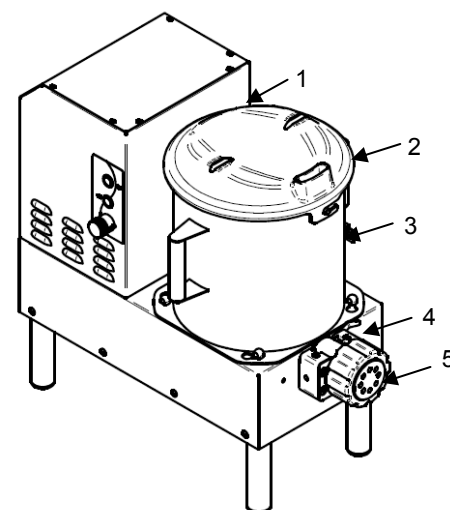

5. Technical specifications

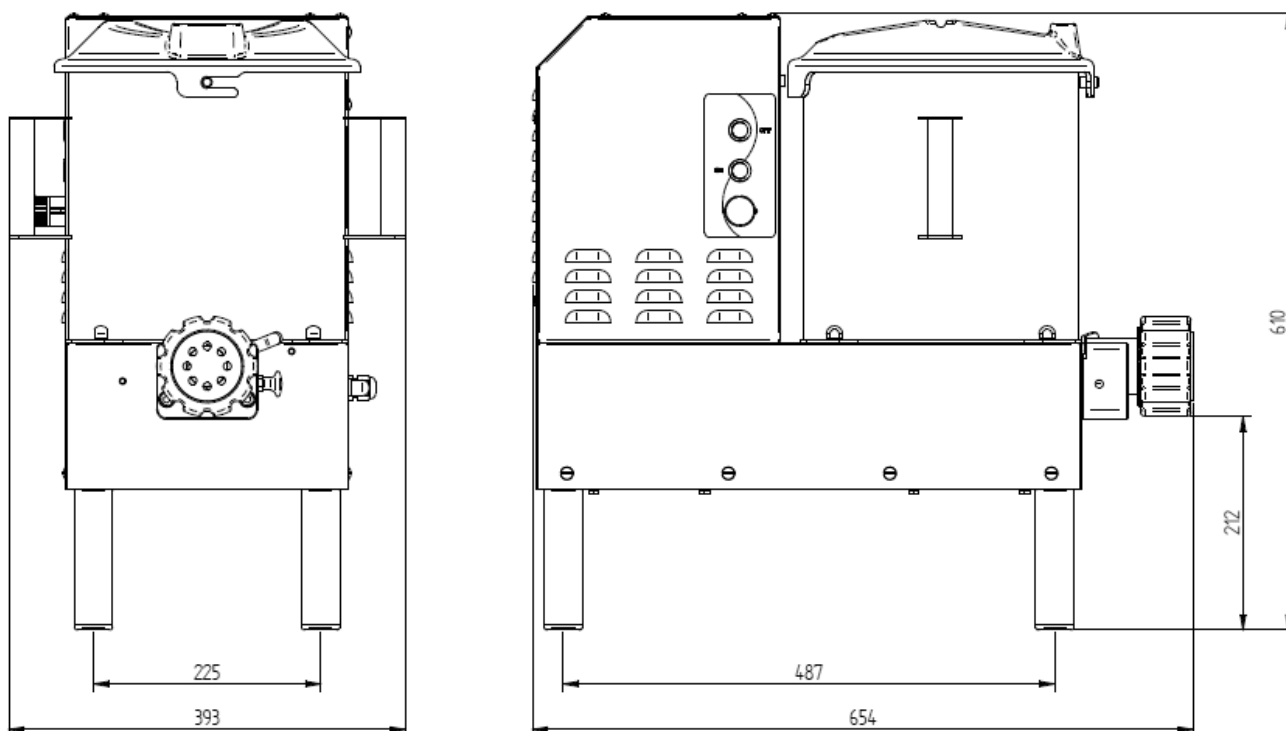

		Upasta-01
Power	<i>Hp</i>	0,75
Voltage/frequency		115V/60Hz
Tank capacity	<i>lt</i>	20
Dough capacity	<i>Kg</i>	4
Production (per hour)	<i>Kg/h.</i>	8/9
Dies	<i>Ø mm</i>	75
Net weight	<i>Kg</i>	52

6. WIRING DIAGRAMS

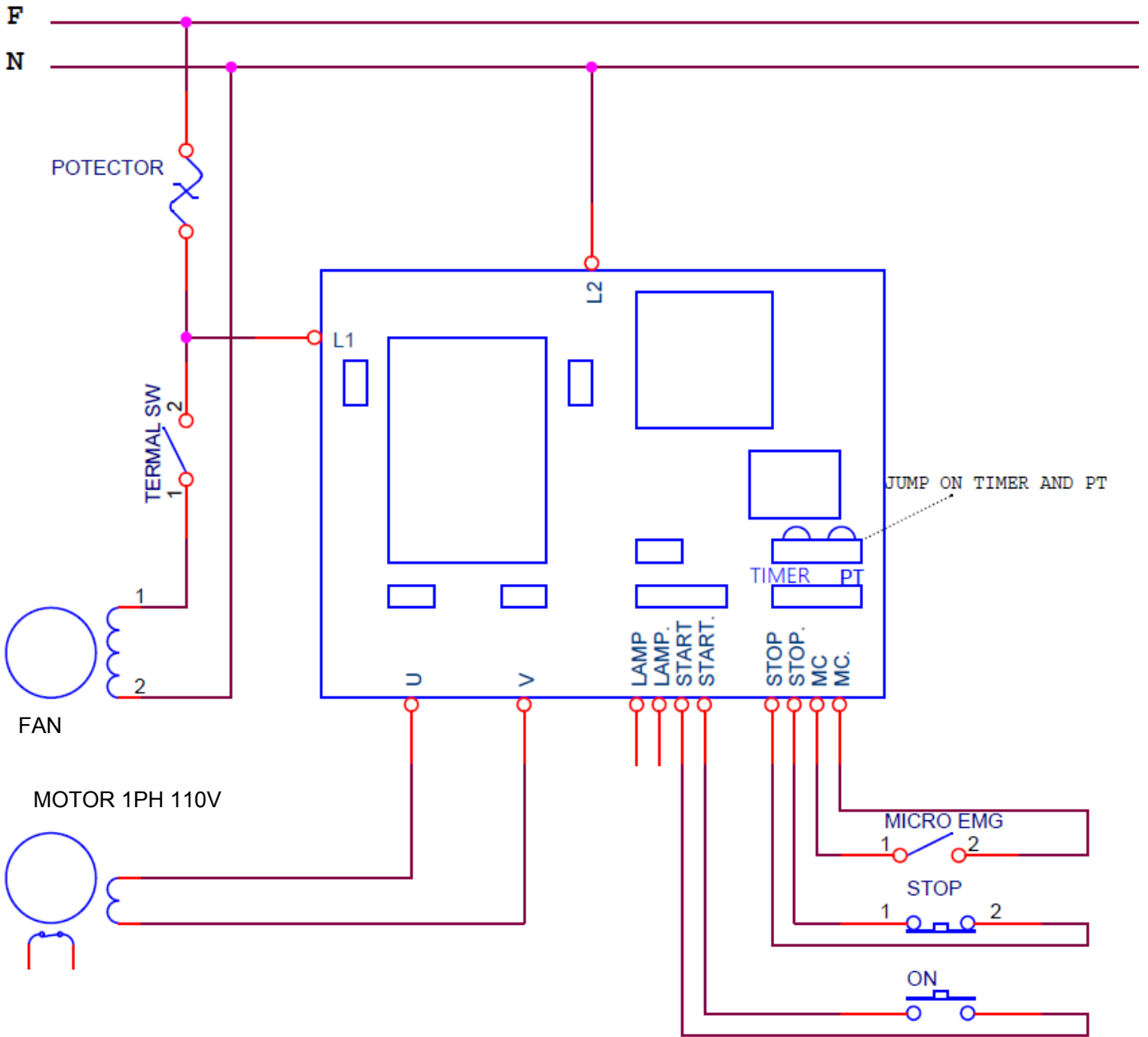



Univex Corp.
3 Old Rockingham Road
Salem, NH 03079 USA

info@univexcorp.com

**SERVICE CENTRE
AUTHORISED DEALER**