

Varimixer



**SPARE PART AND OPERATION MANUAL
FOOD MIXER
Model V80, V80PL, V100PL**

Caution -READ BEFORE OPERATING- Caution

Varimixer recommends that mixer operators must be at least 18 years of age and be thoroughly trained on the use, cleaning and lubrication of the mixer.

This manual should be seen as an integral part of the mixer and should be kept by the machine throughout its working life.

Before the machine is commissioned, it is important to read these instructions thoroughly.

The manufacturer may update the product manual without updating this copy of the manual.

Varimixer recommends that the following precautions be adopted to help make the mixer operation safer and more efficient.

- All operators must be at least 18 years of age.
- All operators must be thoroughly trained before being allowed to operate the mixer.
- NEVER reach into the bowl when the mixer is running.
- Do not wear loose clothing or rings while operating the mixer.
- Stop the mixer and lower the bowl before adding ingredients, scraping the bowl, removing the agitator, or removing the product.
- Stop the mixer before removing or installing attachments into the drive hub.
- Do not attempt to assemble or disassemble attachments while mounted into the drive hub.
- Always use the pusher plate with the slicer/meat grinder attachments.
- NEVER bypass the safety mechanisms supplied on the mixer. Doing so can cause injury and is the responsibility of the user to ensure these safety mechanisms are operating properly.

Limited Mixer Warranty

VARIMIXER warrants to the original purchaser of new equipment that said equipment, when installed in accordance with our instructions within North America and subjected to normal use, is free from defects in material or workmanship for a period of 2 years. Wear parts, such as belts, are excluded. Hub attachments, such as shredders, slicers and grinders have a 1 year warranty that only covers parts. Warranty begins on date of factory shipment to an end user, or up to 6 months after factory shipment to a dealer or distributor. Payment by VARIMIXER for service under this warranty requires that service be authorized in advance. Contact VARIMIXER Technical Support to arrange for service.

THIS WARRANTY IS IN LIEU OF ALL OTHER WARRANTIES, WHETHER EXPRESSED OR IMPLIED. VARIMIXER EXPRESSLY DISCLAIMS ANY IMPLIED WARRANTY OF MERCHANTABILITY OR EXPRESSED OR IMPLIED WARRANTY OF FITNESS FOR A PARTICULAR PURPOSE.

VARIMIXER'S OBLIGATION AND LIABILITY UNDER THIS WARRANTY IS EXPRESSLY LIMITED TO REPAIRING AND REPLACING EQUIPMENT WHICH PROVES TO BE DEFECTIVE IN MATERIAL OR WORKMANSHIP WITHIN THE APPLICABLE WARRANTY PERIOD. All repairs pursuant to this Warranty will be performed by an Authorized Designated VARIMIXER Service Location during normal working hours. IN NO EVENT SHALL VARIMIXER BE LIABLE FOR INCIDENTAL OR CONSEQUENTIAL DAMAGES TO BUYER OR ANY THIRD PARTY, INCLUDING, WITHOUT LIMITATION, LOSS OF PROPERTY, PERSONAL INJURY, LOSS OF BUSINESS OR PROFITS OR OTHER ECONOMIC LOSSES, OR STATUTORY OR EXEMPLARY DAMAGES, WHETHER IN NEGLIGENCE, WARRANTY, STRICT LIABILITY, OR OTHERWISE.

This warranty is given only to the first purchaser from a retail dealer. No warranty is given to subsequent transferees.

This warranty does not cover product failures caused by: failure to maintain, neglect, abuse, damage due to excess water, fire, normal wear, improper set up and use. Periodic maintenance is not covered.

Example of items not covered under warranty, but not limited to just these items:

1. Acts of God, fire, water damage, vandalism, accident, theft.
2. Freight damage.
3. Improper installation or alteration of equipment.
4. Use of generic or after market parts.
5. Repairs made by anyone other than a VARIMIXER designated servicer.
6. Lubrication.
7. Expendable wear parts. (This includes the bowl, flat beater, wire whip, spiral dough hook, and the pastry knife.)
8. Cleaning of equipment.
9. Misuse or abuse.

This warranty is not in force until such time as a properly completed, digitally signed Installation/Warranty Registration has been received by VARIMIXER within 30 days from the date of installation.

Register online at www.varimixerusa.com/support/warranty-registration-form.

THE FOREGOING WARRANTY PROVISIONS ARE A COMPLETE AND EXCLUSIVE STATEMENT BETWEEN THE BUYER AND SELLER. VARIMIXER NEITHER ASSUMES NOR AUTHORIZES ANY PERSONS TO ASSUME FOR IT ANY OTHER OBLIGATION OR LIABILITY IN CONNECTION WITH SAID EQUIPMENT.

WARRANTY REGISTRATION
GO TO WWW.VARIMIXERUSA.COM
TO FILL OUT AND SUBMIT YOUR WARRANTY REGISTRATION.

WWW.VARIMIXERUSA.COM/SUPPORT/WARRANTY-REGISTRATION-FORM

TABLE OF CONTENTS

INSTALLATION INSTRUCTIONS	5
OPERATION OF THE MIXER:	6
PAUSE FUNCTION (POWER LIFT):	6
AUTOMATIC LOWERING OF THE BOWL (POWER LIFT)	7
TIMER FUNCTION:	7
START-UP AFTER STOP AT HIGH SPEED:	7
OVERLOAD:	7
ERROR CODES:	7
CORRECT USE OF TOOLS:	7
CLEANING:	7
CONSTRUCTION OF THE MIXER:	8
CAPACITY CHART	8
MAINTENANCE AND LUBRICATION:	9
GREASE TYPES:	9
RECOMMENDED MAXIMUM SPEEDS:	9
RECOMMENDED MAXIMUM SPEEDS FOR ATTACHMENT HUB:	9
LIST OF ERRORS AND POSSIBLE SOLUTION:	10
ADJUSTMENT OF SPECIAL V-BELT:	10
ADJUSTMENT OF SPEED:	10
ADJUSTMENT OF BOWL CENTERING:	11
ADJUSTMENT OF BOWL FIXING:	11
ADJUSTMENT OF BOWL HEIGHT:	11
MIXER SPARE PARTS	
MACHINE COLUMN V80-V100	13
BOWL LIFT MICROSWITCHES V80-V100	15
MANUAL BOWL LIFT - V80 ONLY	17
POWER BOWL LIFT V80-V100	19
PLANETARY HEAD V80-V100	21
TRANSMISSION V80-V100	23
SPEED LEVER SYSTEM V80-V100	25
ATTACHMENT DRIVE GEARBOX - V80 ONLY	27
BOWL SCREEN V80-V100	29
ELECTRICAL PANEL, MANUAL LIFT V80	31
ELECTRICAL PANEL, POWER LIFT V80 - V100	33
ELECTRICAL POWER SUPPLY, POWER LIFT V80-V100	35
ATTACHMENTS AND OPTIONAL PRODUCTS	37
WIRING DIAGRAM V80 - WITH MANUEL BOWL LIFT 3x208V	38
WIRING DIAGRAM V80 - WITH MANUEL BOWL LIFT 3x480V	39

 Read this page entirely BEFORE beginning installation.

INSTALLATION INSTRUCTIONS

UNDER NO CIRCUMSTANCES ARE THE SPEED LEVER, BOWL LIFT LEVER, OR THE BOWL ARMS TO BE USED TO MOVE THE MIXER INTO PLACE. DAMAGE WILL RESULT TO THE UNIT.

IT IS RECOMMENDED THAT THE TOP LID BE REMOVED BEFORE MOVING THE UNIT.

The mixer must be mounted with the rubber feet, which neutralize both shaking and rusting. Spacers can be inserted under the mixer's feet if the floor is uneven. The mixer can be bolted to the floor if desired.

Before the mixer is connected to power, it should be checked that the voltage and frequency on the rating plate is correct in relation to the place of installation. A unit labeled 220V 3 Phase will operate from 208V to 240V 3 phase safely. The rating plate is located on the rear right side of the mixer. The electrical connection box is located at the top rear of the mixer.

WARNING

Electrical and grounding connections must comply with applicable portions of the National Electrical Code and/or other local electrical codes.

Wire Color Codes

White-Phase 1

Red -Phase 2

Black-Phase 3

Green-Ground

No Neutral is used

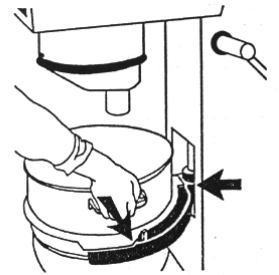
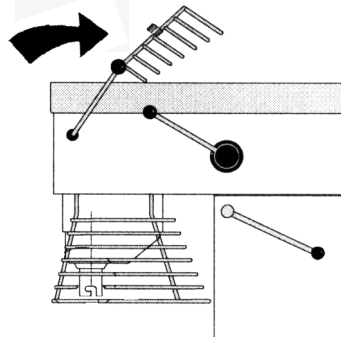
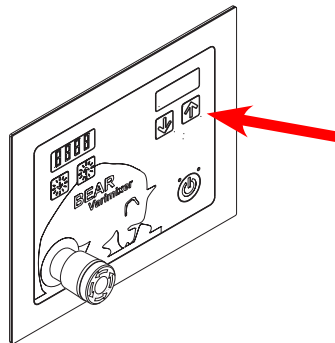
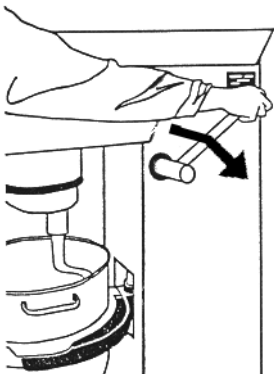

1. Lower the bowl using the bowl lift lever or press the button for bowl lift on the front panel.
2. Open the bowl screen.
3. Remove the bowl and tools.

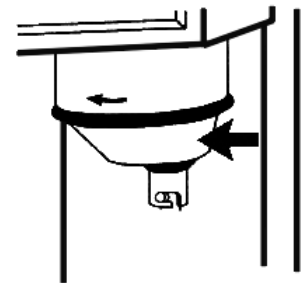
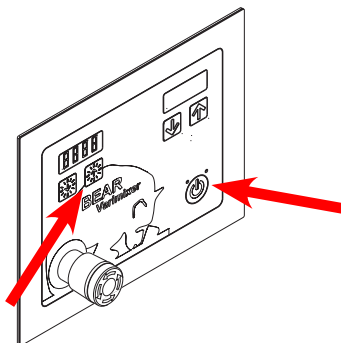
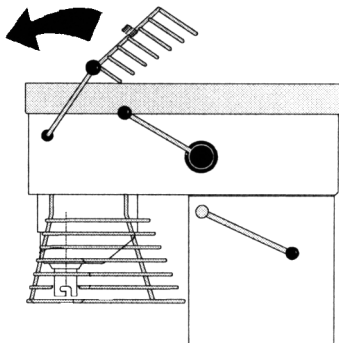

4. Close bowl screen and raise the bowl arms into the up position.
5. Set timer to 10 minutes and push "start".
6. Insure cover is rotating in the correct direction.

OPERATION OF THE MIXER:

- A) Place the tool in the bowl. Open the bowl screen
- B) **Note: the bowl arms must be in the lowest position.** Place the bowl in the bowl arms. Check that the bowl is pushed right back into the arms and that the “centre ear” of the bowl arms is facing the mixer (**fig. 3**). Place the mixer tool in the bayonet shaft. The tap of the tool must be turned right into the bayonet hole. Close the bowl screen.
- C) Raise the bowl to working position by turning the handle for bowl lift towards your selves (**fig. 2**) (manual bowl lift) or by pressing **↑** (**fig. 1**) (Power lift). The bowl will automatically stop in the top position.

- D) The mixing time can be set on the timer using the and buttons. The mixer stops automatically when the mixing time has run out. (If the mixer stops at high speed when the mixing time runs out, follow the instructions “Start-up after stop at high speed” before starting the mixer again).

You can also start the mixer without setting a time. If you do not set a time, the display will function as a clock that counts up. See also “Timer function” on page 7

- E) Start the mixer by pressing (**fig.1**)
- F) Turn the speed selector lever (**fig. 2**) to the rear until the required speed has been obtained, (notice the recommended maximum speeds on page 9).



The speed must be changed only when the mixer is running.

The mixer must not be started in high speed when loaded.

Always change to low speed before stopping the mixer

- G) **Only for power Lift!**
During the mixing process the mixer can be paused by pressing (**first change to low speed**). You can now lower the bowl or open the bowl screen. If you start the mixer again using the timer settings will be unchanged.
- H) Before the mixer is stopped, the speed selector lever must be moved back to lowest speed (**fig.2**). Stop the mixer by pressing (**fig.1**).
- J) When the tool has stopped rotating the bowl can be lowered by pressing (power lift) or by turning lever for bowl lift to the rear.

PAUSE FUNCTION (POWER LIFT):

The mixer has a pause button , which should be used to stop and start the mixer in a process where the timer is used.

- Change to low speed
- Stop the mixer using . The timer will continue to count downwards when you start the mixer again by pressing .
- When you stop the mixer pressing you can lower the bowl and open the bowl screen. When you press again, the timer continues to count downwards.
- If you start the mixer using the settings will be reset. See also “Pause function”

Fig. 1 Operation panel.

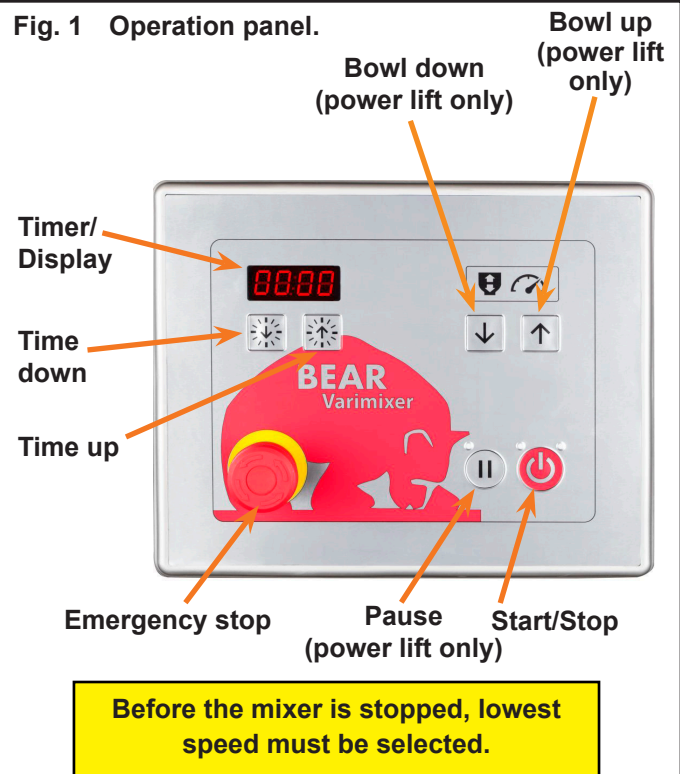

Fig. 2

Speed selector and manual Bowl lift.

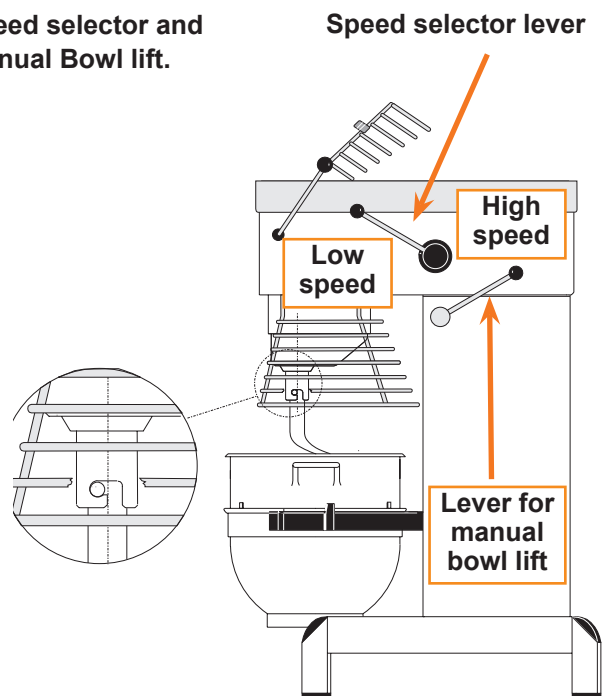
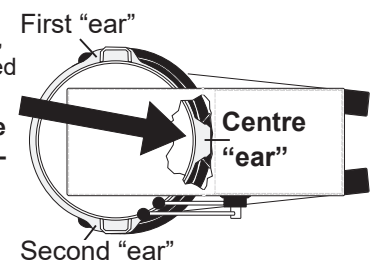





Fig. 3

Mixer seen from above, the bowl has been pushed all the way into the bowl arms. Notice: the centre “ear” of the bowl is facing the mixer





AUTOMATIC LOWERING OF THE BOWL (POWERLIFT)

If the timer is in use, the bowl can automatically be lowered when the time runs out and the mixer stops.



- While the mixer is running, briefly press . The green LED by  will flash until the mixer stops.
- When automatic lowering of the bowl is selected it is important that you use  (first change to low speed) to stop and start the mixer, otherwise the selection will be reset.

TIMER FUNCTION:

The mixer has an optional timer function. If no time is set on the timer, the display will instead show the time the mixer has run for.

- The timer can be set to a maximum of 60 minutes.
-  and  can be used to set the time before starting the mixer or while the mixer is running. The time can be changed after it has been set.
- **When the time runs out the mixer will stop in the selected speed.**

START-UP AFTER STOP AT HIGH SPEED:

This procedure is used in all cases where the mixer has been interrupted at high speed, either because the mixer has been stopped using  or , the mixing time has run out, the emergency stop is activated or the bowl screen is opened:

- 1) Lower the bowl and remove the tool from the bayonet.
- 2) Raise the bowl arms, either empty or with the bowl.
- 3) Close the bowl screen, start the mixer and move the speed selector lever back to lowest speed.
- 4) Switch off the mixer. Now the mixer can be started as usual.

OVERLOAD:



Do not overload the mixer. Sticky and heavy doughs can overload the mixer. Overloading is further exacerbated if the speed of the mixing tool is increased beyond the recommended values or if a wrong mixing tool is used. Large lumps of fat or cooled ingredients must be cut into small parts before they are placed in the bowl.

Longer time overload will interrupt the mixer.

OH will be written in the mixer's display. After a short while the display will change back to normal mode and you can start the mixer again as described in **"Start-up after stop at high speed"**.

ERROR CODES:

If the mixer is overloaded, the motor will stop and  will be shown for 'overheat' in the display.

- Allow the mixer to cool down.
- After a short time, the display will change to normal mode.
- The mixer can be started again. See also the section **"Start-up after stop at high speed"**.

CORRECT USE OF TOOLS:



Whips should not be struck against hard objects as e.g. the edge of the bowl. This will make the life of the tool shorter due to increasing deformity.

Recommended applications for tools:

Whip	Beater	Hook
Cream	Cake dough	Bread dough
Egg whites	Butter cream	Dark bread
Mayonnaise and the like	Waffle dough	and the like
	Minced meat and the like	



For production of mashed potatoes the special wing whip or the whip with thicker wires should be used, alternatively use the beater and the whip.

NOTE: Speed should never exceed 150 RPM when using the dough hook. Our dough hook is designed to give you optimum product on low speed.

CLEANING:



The mixer should be unplugged before cleaning to prevent accidental starting while cleaning.

The mixer should be cleaned daily or after use.

The mixer should be cleaned with a soft cloth and clean water. Sulphonated soaps should be used with caution as they destroy the mixer's lubricants.



Never use high pressure cleaning for the mixer.

Parts made of aluminum should not be used to strongly acidic, highly alkaline or highly salty foodstuffs, which may attack aluminum without coating.

Tools of aluminium must not be washed with strong alkaline detergents (pH between 5 and 8).

The soap suppliers can recommend the correct type of soap.

The inside of the beater shaft should be cleaned once a day with warm, soapy water.

Dough hook Cleaning: Special care should be given to cleaning the dough hook. We recommend that it be cleaned and sanitized in a commercial dish machine. An alternate cleaning procedure is to vigorously scrub the hook with a hot water and detergent solution. Use a heavy bristled brush. After cleaning, sanitize the hook by rinsing it with a 50 ppm solution of sodium hypochlorite.

Cleaning of attachment hub: after use of the attachment hub this should be wiped inside with a soft cloth.

CONSTRUCTION OF THE MIXER:

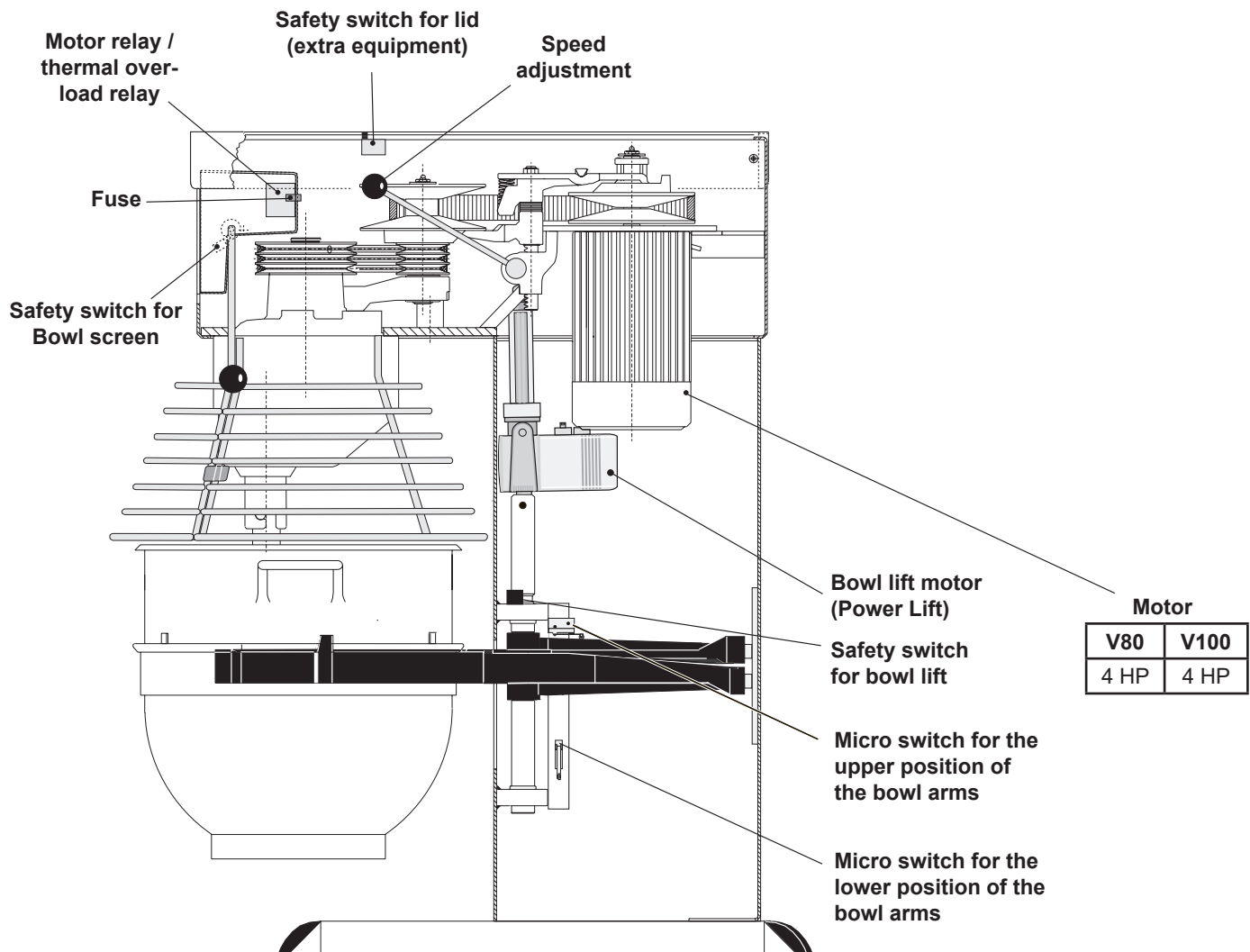

CAPACITY CHART

Product	V80	V100
Dough, Bread-65%AR	105 Lbs.	155 Lbs.
Dough, Pizza-50% AR	90 Lbs.	135 Lbs.
Dough, Donut-Yeast	80 Lbs.	150 Lbs.
Dough, Donut-Cake	60 Lbs.	140 Lbs.
Pie Dough	69 Lbs.	95 Lbs.
Cookie, Dough	68 Lbs.	105 Lbs.
Muffins	90 Lbs.	125 Lbs.
Mashed Potatoes	58 Lbs.	76 Lbs.
Pancakes, Waffles	35 Qts.	44 Qts.
Whipped Cream	16 Qts.	20 Qts.
Cake, Layer	92 Lbs.	125 Lbs.
Eggs & Sugar	40 Lbs.	57 Lbs.
Icing , Fondant	50 Lbs.	76 Lbs.
Egg Whites	2.5 Qts	3 Qts.
Cake, Cup	140 dz.	178 dz.
Cookies, Sugar	132 dz	171 dz.

AR = Absorption Ratio (%AR)
(Liquid in % of solids)

Water weights
 1 Gallon =8.33 lbs.
 1 Quart =2.08 lbs.
 1 Pint (16 oz.) =1.04 lbs.
 1 Cup = .52 lbs.

Batch size and/or speed reduction may be necessary due to one of the following conditions:

- 1.High Gluten Flour-Reduce batch size by 10%
- 2.AR % under 40%-Reduce batch size by 10%
- 3.Water temp under 65 Degrees F
- 4.USE OF ICE REQUIRES A 10% REDUCTION IN BATCH SIZE.
5. Speed should not exceed 100 RPM when mixing dough.

MAINTENANCE AND LUBRICATION:

The infinitely variable gear must be lubricated regularly, i.e. a lubrication interval of approx. 60 hours of operation.

Lubrication of infinitely variable gear:

OBS. Special grease !!(Use the grease gun delivered together with the mixer). Start the mixer and increase the speed to approx. 50%. Stop the mixer (use the emergency stop) and open the lid on the top of the mixer. On the top of each of the two pulley set shafts is a grease nipple (**fig. 4 point 1**). Press grease through the grease nipples.

until the grease gun feels hard to press or until grease comes out between the shaft and the pulleys.



The mixer must not be started until the screws which hold the lid are inserted.

Start the mixer, and set the speed back to low speed.

Stop the mixer and fill the grease gun with new grease so that it is ready for next time.

Lubrication of other movable parts:

The movable parts of the bowl arms, the shaft and the lifting rod must also be lubricated with oil. Remove the rear covering and lubricate the marked points with an oil can. (**fig.4 pkt.2**)

GREASE TYPES:

Grease for the pulley set shafts: **Castrol High Temperature Grease.**

On repair of the planetary head: Grease the toothed wheel and the toothed rim with **Nye Gel 868VH, (PN 868VH)**, the needle bearings in the planetary head must not be lubricated with this type of grease they should be lubricated with **PN Sapphire 2**. Do not use any another type of grease than the one stated here.

On repair of the attachment hub: Fill the attachment hub with **GreaseWay LiCa 80**

RECOMMENDED MAXIMUM SPEEDS:

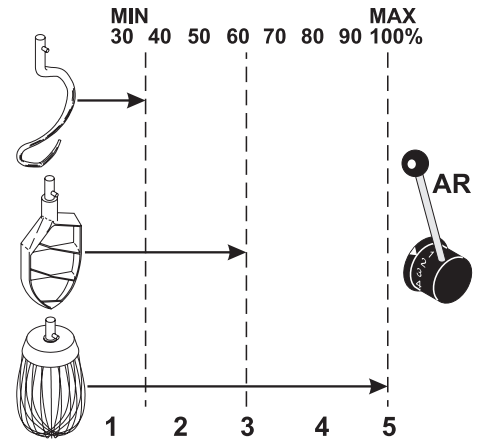

RECOMMENDED MAXIMUM SPEEDS FOR ATTACHMENT HUB (V80):

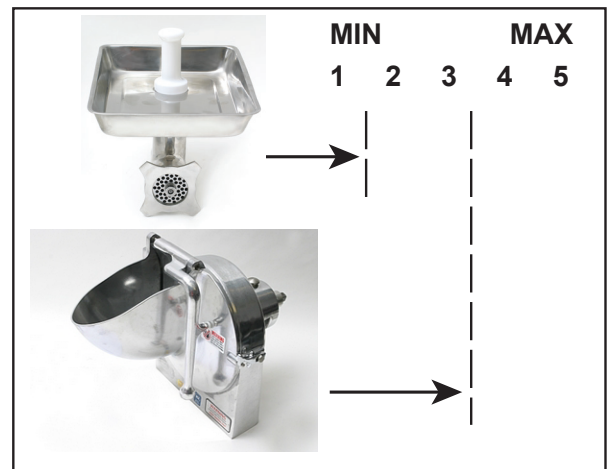
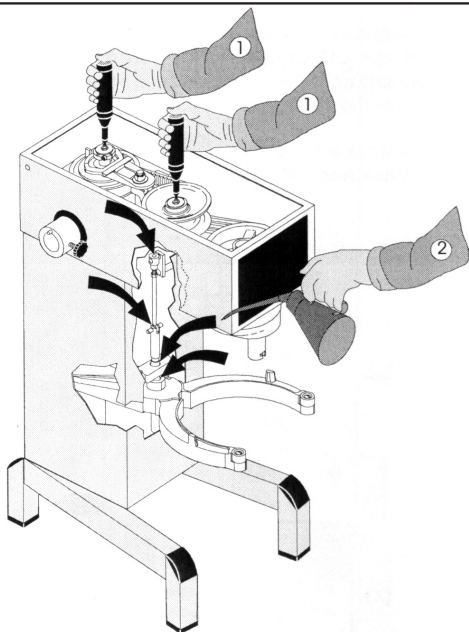

fig.4



LIST OF ERRORS:

POSSIBLE SOLUTION:

A rattling sound from the closed part of the mixer.

Adjustment of special v-belt

The mixer starts "striking" when kneading dough which normally causes no problems.

Adjustment of special v-belt

The mixer changes its speed by itself.

Adjustment of special v-belt

The minimum and the maximum speeds are changing.

Adjustment of speed.

The bowl is too tight or too loose.

Adjustment of bowl fixing

The tool hits the sides of the bowl.

Adjustment of bowl centering

The tool hits the bottom of the bowl.

Adjustment of bowl height



Prior to a possible repair or adjustment, switch off the mixer by disconnecting the power cable.

ADJUSTMENT OF SPECIAL V-BELT:

The distance (X) (Fig. 5) is only indicative as it depends on the tolerance of the special V-belt.

1. Start by tightening the v-belts (*).
2. Tighten the special V-belt (A) by moving one or two washers from (V) to (T).
3. Start the mixer and leave it running while the nut (U) is tightened. Do not tighten it too much.
4. On the front pulley set the stud (E) on the varispeed collar (F) and on the rear pulley set outside the fork for belt tightener (B), (both must point backwards).
5. Tolerances in the transmission might cause that the special V-belt (A) is hitting the pins of the pulley sets when the speed has been adjusted. In such cases the distance (X) must be reduced. (+ or - 1/8" of 12 1/4")
6. Then follow the section: "Adjustment of speed"

ADJUSTMENT OF SPEED:

1. The stop screws (J) (Fig. 5) on the speed lever should be adjusted so that the measurement (H) is 1-2 mm on the front and the rear pulley, at low and high speed, respectively. Tighten the counter nuts (K) when the speed is correctly adjusted.
2. Tolerances in the transmission might cause that the special V-belt (A) is hitting the pins of the pulley sets (Z) when the speed has been adjusted. In such cases the distance (X) must be reduced, see "Adjustment of special v-belt", and the speed must be readjusted.

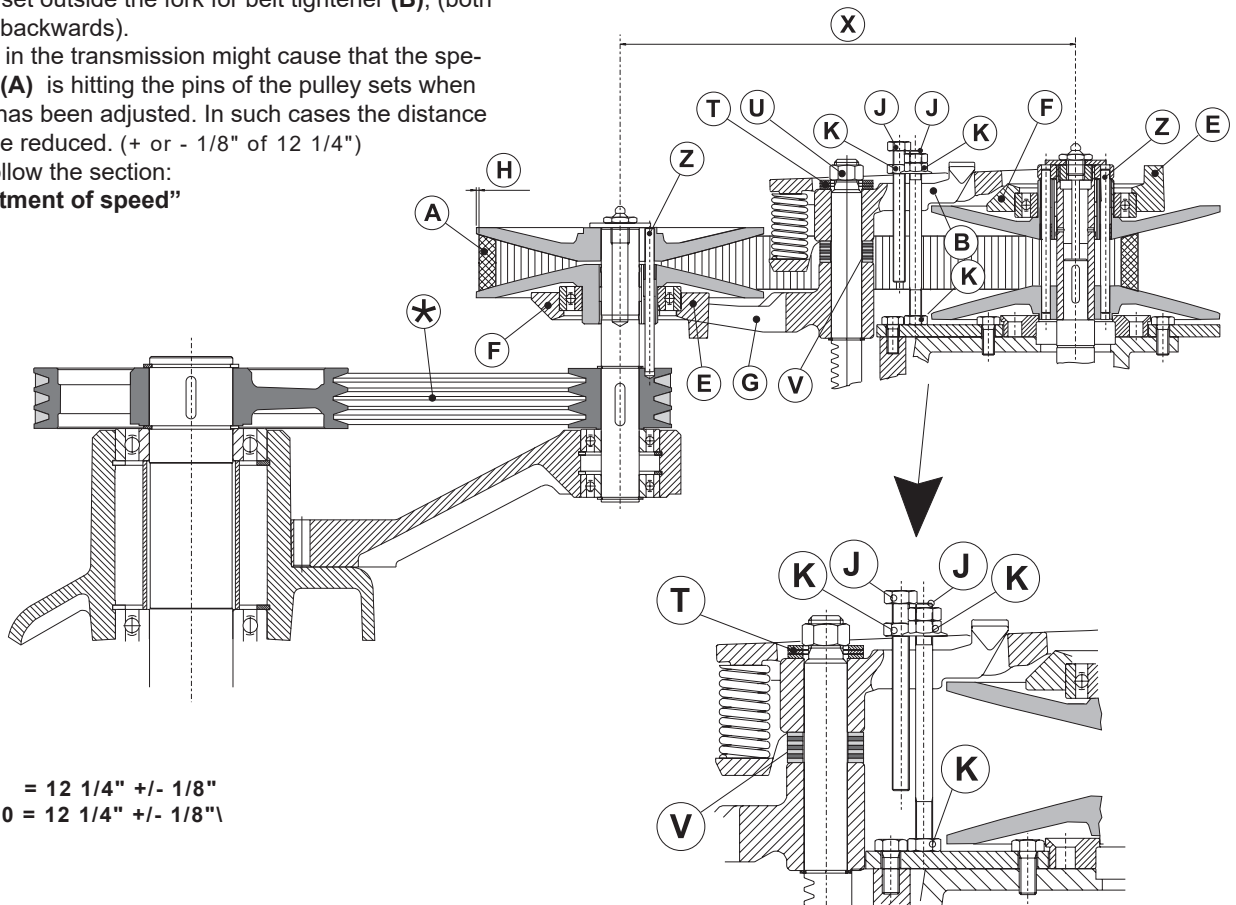

(X) V80 = 12 1/4" +/- 1/8"
 (X) V100 = 12 1/4" +/- 1/8"

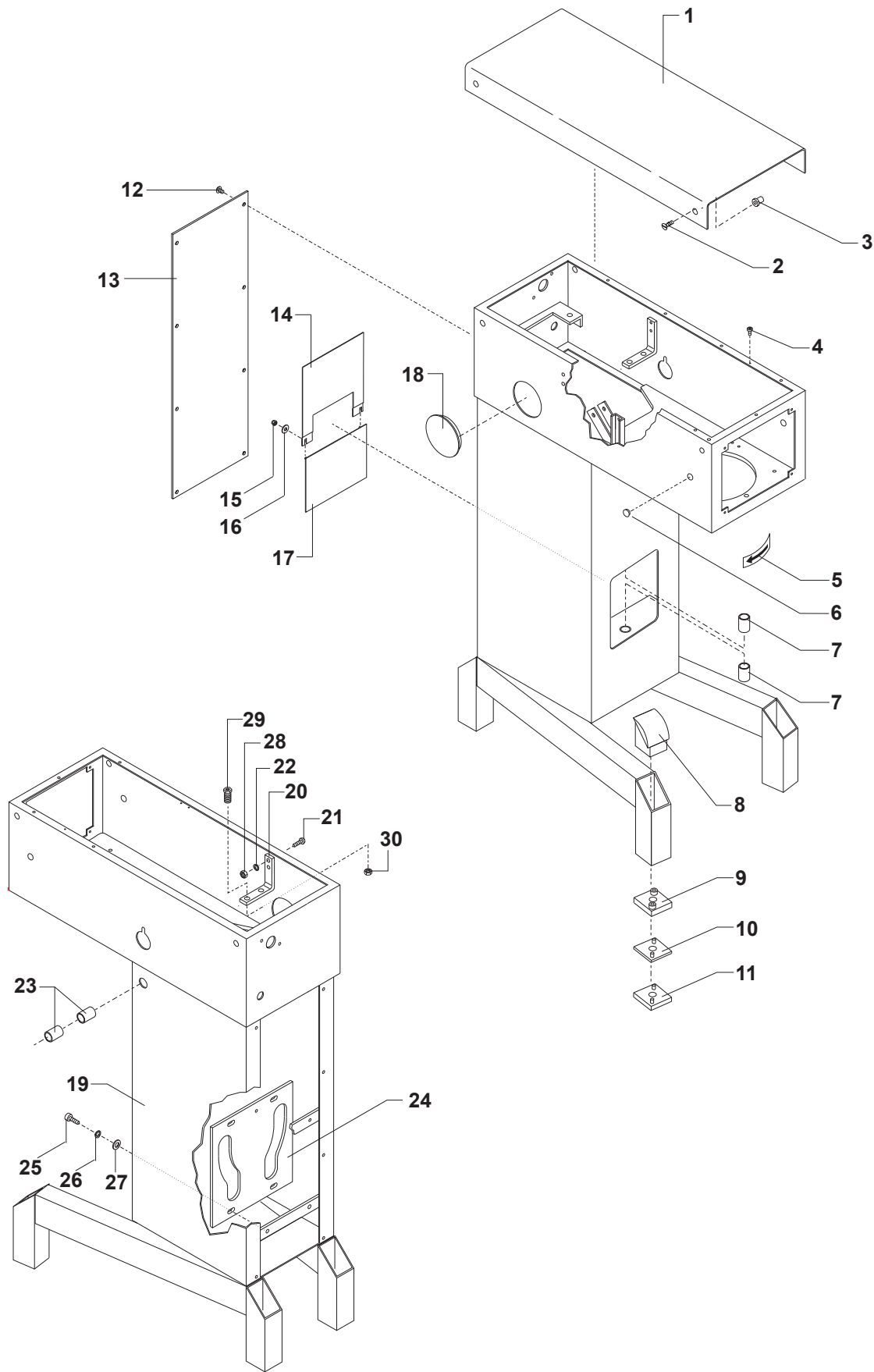

MACHINE COLUMN V80-V100

Fig.No	Description	V80	V100
1.	Top Lid	AR81-21	AR101-21
2.	Screw for Lid M6x20.....	STA 5017	STA 5017
3.	Threaded Bushing	STA 6580.....	STA 6580
4.	Ground Screw.....	STA 5232.....	STA 5232
5.	Arrow Label	R15-245.....	R15-245
6.	Plug Button	STA 6525.....	STA 6525
7.	Bushings for Bowl Arm Shaft.....	STA 2526.....	STA 2526
8.	Knee Pad.....	AR80-212	AR80-212
9.	Foot	AR80-213	AR80-213
10.	3MM Foot	AR80-214.3	AR80-214.3
11.	6MM Foot	AR80-214.6	AR80-214.6
12.	Screw M6X10	STA 5080.....	STA 5080
13.	Rear Panel.....	AR81-22.17R.....	AR101-22.17R
14.	Upper NSF Plate	AR81-270	AR81-270
15.	Lock Nut	STA 5834.....	STA 5834
16.	Washer	STA 6027	STA 6027
17.	Lower NSF Plate	AR81-271	AR81-271
18.	Plug Button f/ No Hub.....	STA 6510.....	N/A
19.	Machine Column.....	AR81-22M0	AR101-22M0
20.	Motor mount	AR81-148.1	AR81-148.1
21.	Bolt	STA 5686.....	STA 5686
22.	Washer	STA 6056.....	STA 6056
23.	Bushings for Bowl Lift Lever.....	STA 2515.....	N/A
24.	Bowl Arm Guide Plade.....	AR81-71	AR81-71
25.	Screw.....	STA 5322.....	STA 5322
26.	spring washer	STA 6056.....	STA 6056
27.	Washer	STA 6020.....	STA 6020
28.	Nut.....	STA 5810.....	STA 5810
29.	Threaded Bush	R20-148.....	R20-148
30.	Nut.....	STA5815.....	STA 5815

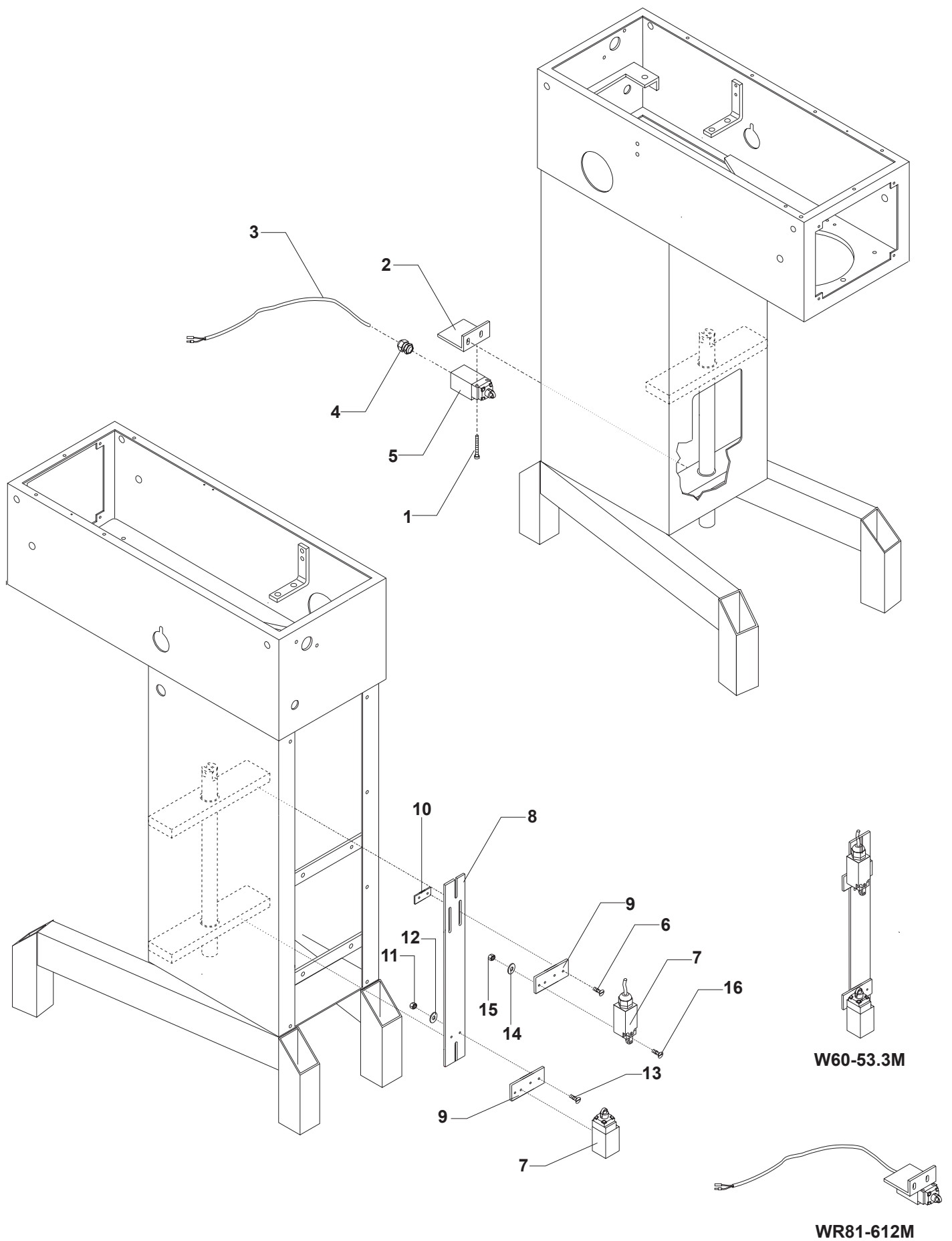

BOWL LIFT MICROSWITCHES V80-V100

Fig.No	Description	V80 - V100
1.	Screw.....	STA 56277
2.	Microswitch Bracket.....	AR81-612
3.	Microswitch Cable	AR81-194.11
4.	Cable Inlet	STA 3002
5.	Microswitch.....	WR81-194.11
6.	Screw.....	STA 5619
7.	Microswitch.....	AR81-173
8.	Microswitch Bracket.....	AR61-53.1
9.	Microswitch Plate.....	AR61-53.3
10.	Threaded Plate	AR31-712
11.	Nut.....	STA 5819
12.	Washer	STA 6053
13.	Screw.....	STA 5619
14.	Washer	STA 6085
15.	Nut.....	STA 5816
16.	Screw.....	STA 5274
	CE Microswitch assy.....	W60-53.3M
	Microswitch for lift.....	WR81-612M

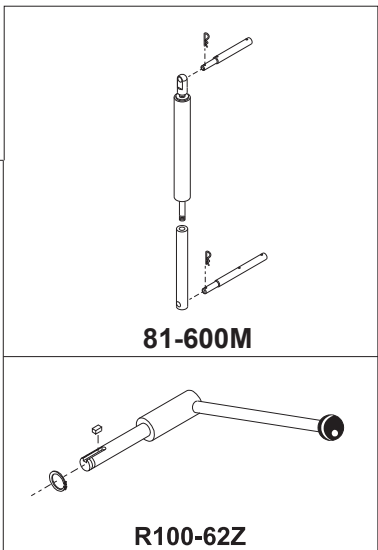
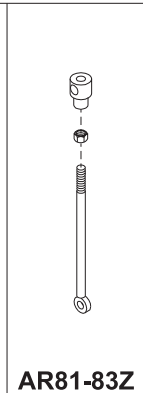
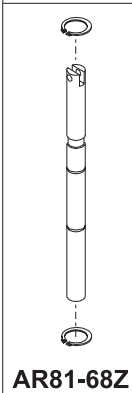
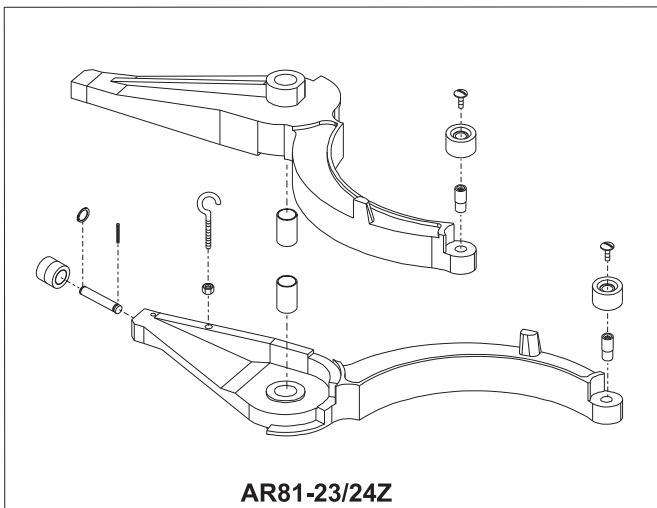
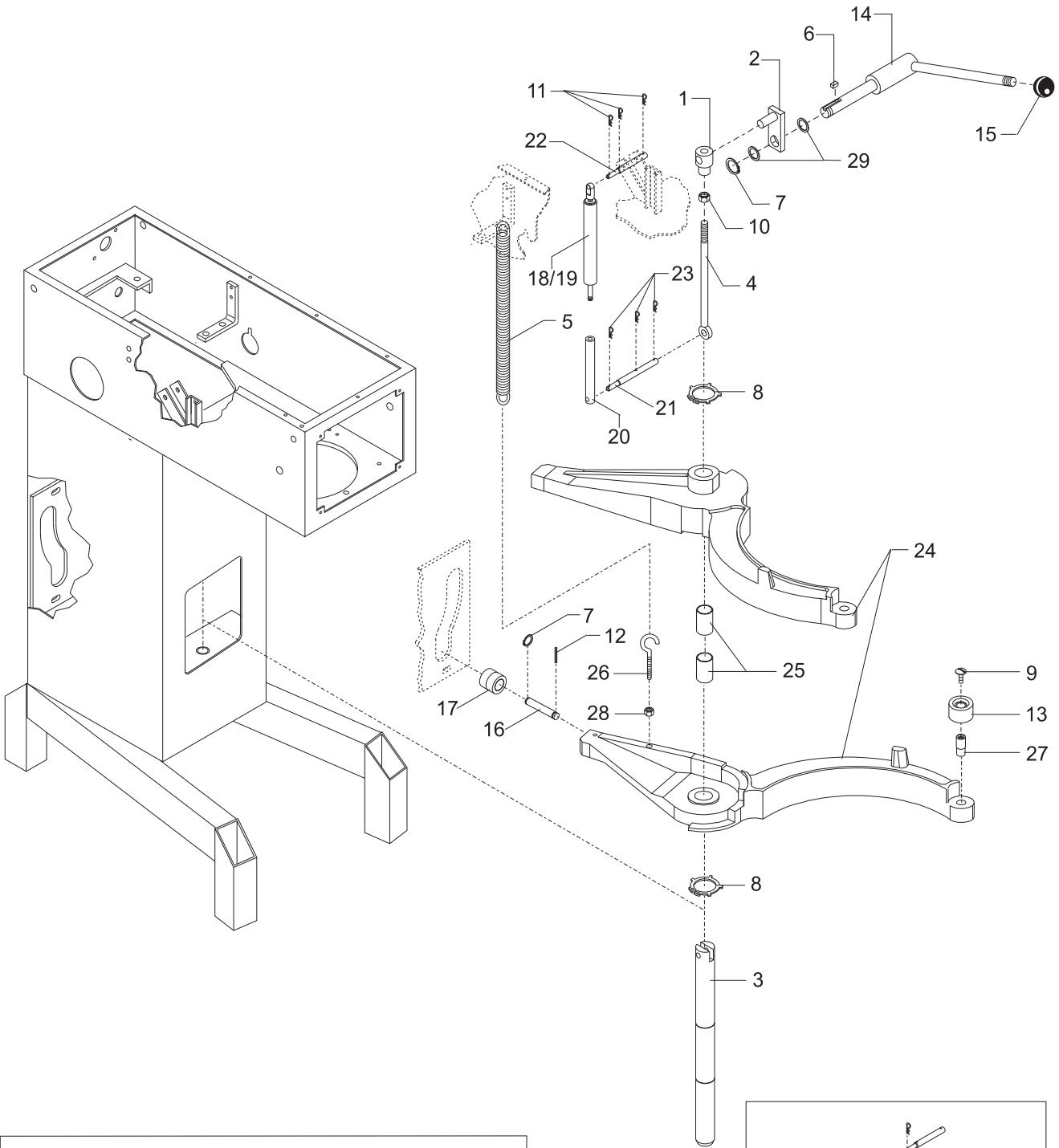

MANUAL BOWL LIFT - V80 ONLY

Fig.No	Description	V80
1.	Lift Nut	R15-65
2.	Crank Arm.....	R60-63Z
3.	Bowl Arm Shaft.....	R81-68Z
4.	Lifting Rod	R81-83Z
5.	Lift Spring	R60-110
6.	Key	STA 2020
7.	Snap Ring.....	STA 3408
8.	Snap Ring.....	STA 3462
9.	Screw.....	STA 5088
10.	Nut.....	STA 5827
11.	Pin	STA 6205
12.	Pin	STA 6370
13.	Roller	AR31-128
14.	Lift Lever.....	R100-62Z
15.	Ball.....	STA 3308
16.	Shaft.....	AR81-71.10
17.	Roller	AR81-71.5M
18.	Bowl Lift Dampener	W60-604
19.	Bowl Lift Dampener, assy	AR81-600.1M
20.	Cotter Pin.....	AR81-606
21.	Pin For Lift/Dampener	AR81-67.1
22.	Upper Mounting Bracket F/Dampener	AR81-609.1
23.	Cotter Pin.....	STA 6205
24.	Bowl Arm Set.....	AR81-23/24Z
25.	Bushings for Bowl Arms.....	STA 2526
26.	Eye Bolt for Bowl Arm Spring	STA 5550
27.	Roller Shaft.....	AR31-127
28.	Nut.....	STA 5819
29.	Washer	STA 6044

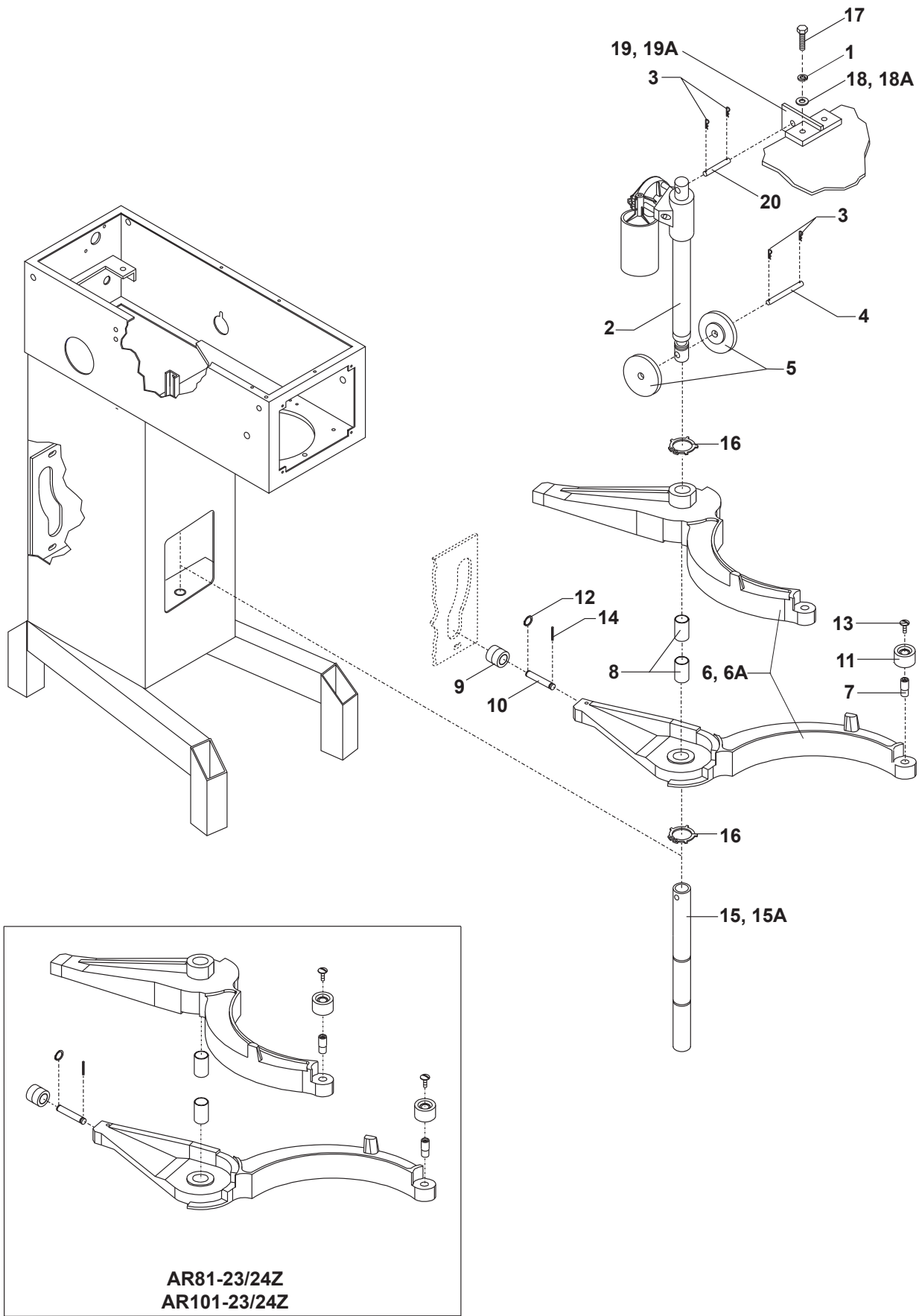

POWER BOWL LIFT V80-V100

Fig.No	Description	V80 - V100
1.	Washer	STA 6056
2.	Bowl Lift Motor.....	AR30-86.2B
3.	Pin	STA 6205
4.	Lifting Rod	RN100-67
5.	Guide	RN100-66
6.	Bowl Arm Set for V80	AR81-23/24M2
6A.	Bowl Arm Set for V100	AR101-23/24M2
7.	Roller Shaft.....	AR31-127
8.	Bushings for Bowl Arms.....	STA 2526
9.	Roller	AR81-71.5M
10.	Shaft	AR81-71.10
11.	Roller	AR31-128
12.	Snap Ring.....	STA 3407
13.	Screw.....	STA 5088
14.	Pin	STA 6370
15.	Bowl Arm Shaft for V80	AR81-68Z
15A.	Bowl Arm Shaft for V100	AR101-68Z
16.	Snap Ring.....	STA 3462
17.	Screw.....	STA 5322
18.	Washer for V80.....	STA 6020
18A.	Washer vor V100.....	STA 6034
19.	Fitting for Bowl Lift Motor for V80	AR81-86.40M4
19A.	Fitting for Bowl Lift Motor for V100	AR101-86.40
20.	Pin	AR81-86.41

V80 3 belts total
V100 4 belts total

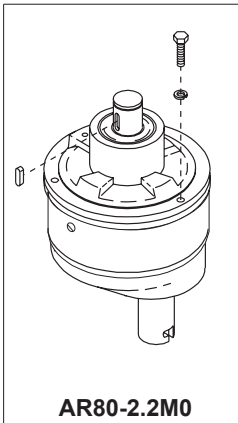
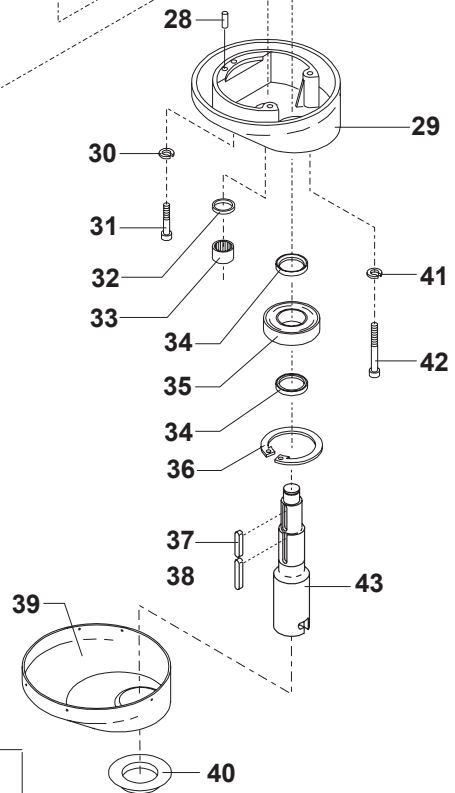
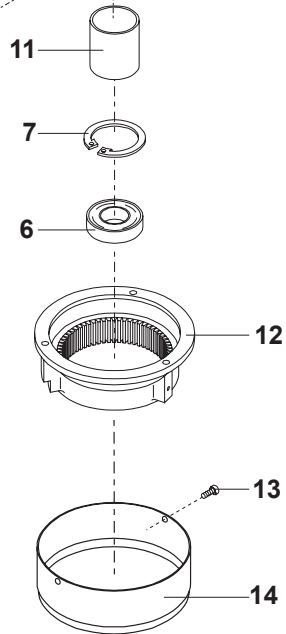
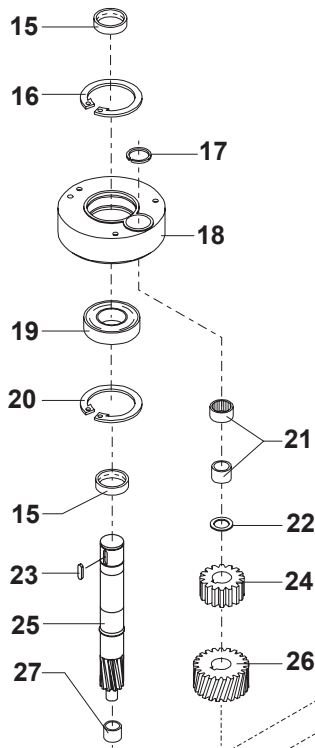
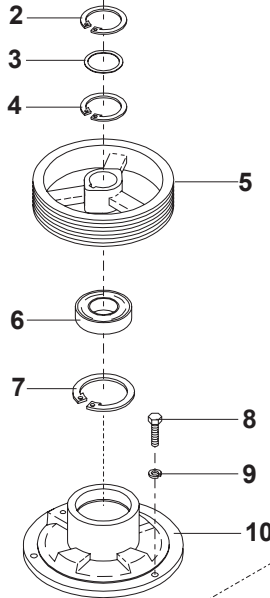
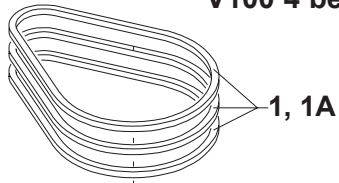

AR80-2.2M0

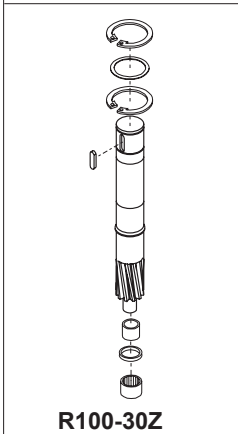

R100-30Z

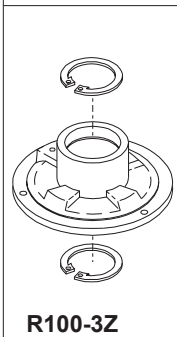

R100-3Z

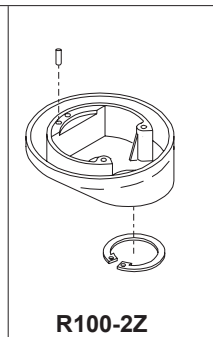

R100-2Z

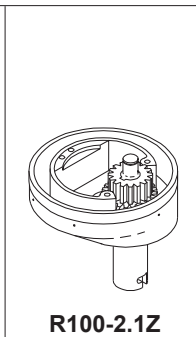

R100-2.1Z

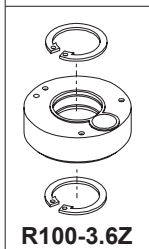

R100-3.6Z

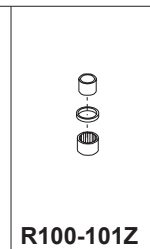

R100-101Z

PLANETARY HEAD V80-V100

<u>Fig.No</u>	<u>Description</u>	<u>V80 - V100</u>
1.	V-Belt for V80 (Must be changed as a set).....	R100-90.1 Order qty 3
1A.	V-Belt for V100 (Must be changed as a set).....	RN100-90.2 Order qty 4
2.	Snap Ring.....	STA 3419
3.	Washer.....	STA 6048
4.	Snap Ring.....	STA 3419
5.	Planetary Pulley.....	R100-129A
6.	Ball Bearing.....	R100-99
7.	Snap Ring.....	STA 3532
8.	Bolt.....	STA 5346
9.	Lockwasher.....	STA 6057
10.	Main Bearing Casting.....	R100-3
11.	Distance Tube.....	R100-141
12.	Gear Wheel.....	R100-1
13.	Screw.....	STA 5044
14.	Cap.....	AR80-162H
15.	Spacer.....	R100-37
16.	Snap Ring.....	STA 3530
17.	Snap Ring.....	STA 3478
18.	Eccentric Disc.....	R100-36Z
19.	Ball Bearing.....	R100-100
20.	Snap Ring.....	STA 3530
21.	Needle Bearing w/ Race.....	R100-96
22.	Washer.....	R100-235
23.	Key.....	STA 2030
24.	Upper Rim Pinion.....	AR140-31
25.	Main Shaft.....	R100-30Z
26.	Lower Rim Pinion.....	R100-32.1
27.	Race for Needle Bearing.....	R100-101Z
28.	Pin.....	STA 6460
29.	Lower Planetary Head Casting.....	R100-2
30.	Lockwasher.....	STA 6057
31.	Bolt.....	STA 5644
32.	Seal.....	R100-101Z
33.	Needle Bearing w/Race.....	R100-101Z
34.	Spacer.....	R100-37
35.	Ball Bearing.....	R100-97
36.	Snap Ring.....	STA 3532
37.	Key.....	STA 2034
38.	Key.....	STA 2039
39.	Stainless Steel Cover.....	W100-272
40.	Rubber Ring.....	R100-209
41.	Lockwasher.....	STA 6057
42.	Bolt (Allen Head-under cover).....	STA 5650
43.	Bayonet Shaft.....	RN100-33.2

AR80-2.2M0.....Planetary head assy
R100-30Z.....Main shaft assy.
R100-3Z.....Main bearing mounted
RN100-33.2Z.....Bayonet shaft assy.
R100-2Z.....Eccentric head compl.
RN100-2.1Z.....Eccentric head mounted
R100-36Z.....Eccentric disc mounted

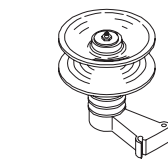
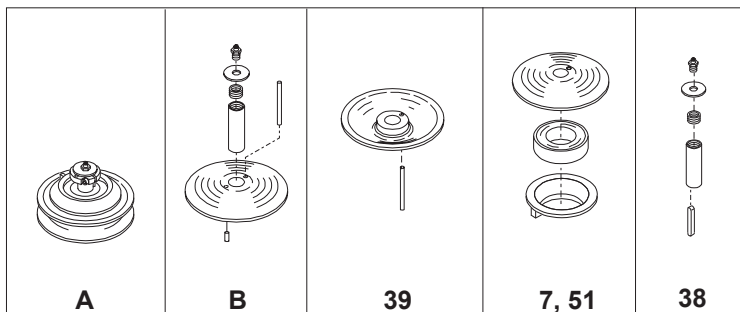
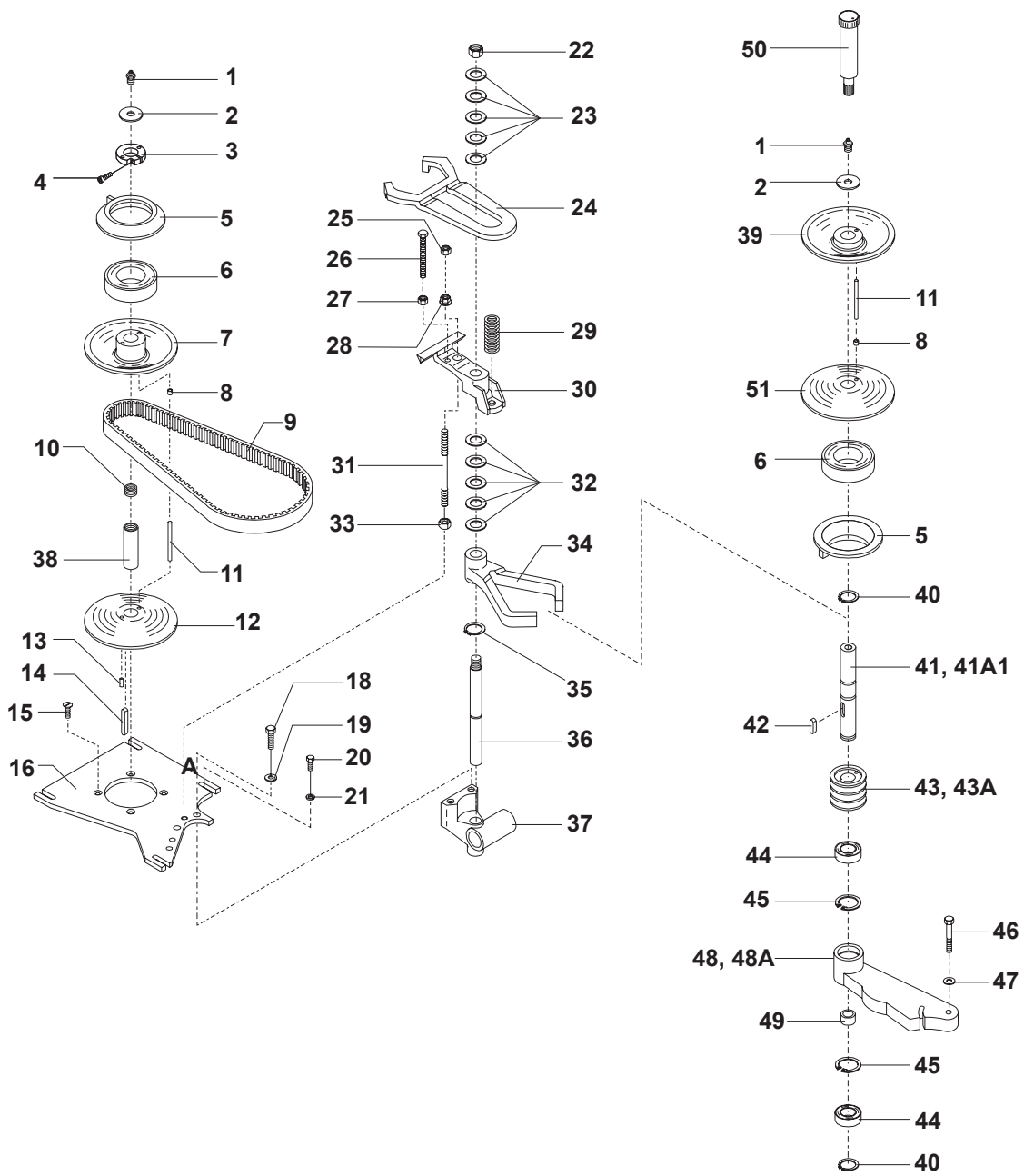

100-6M 100N-6M
V80 3-belt V100 4-belt

TRANSMISSION V80-V100

Fig.No	Description	V80 - V100
1.	Grease Zerk.....	STA 3220
2.	Washer	STA 6018
3.	Clamping Ring w/screw.....	R27-227E
4.	Screw f/clamping ring	STA 5627
5.	Vari Speed Collar.....	R15-17.1
6.	Ball Bearing	R15-103
7.	Movable Pulley	R60-15Z
8.	Bushing.....	STA 2505
9.	Vari Speed Belt.....	R60-91
10.	Reducer	R15-156
11.	Drive Pin.....	R60-285
12.	Motor Pulley Bottom Half Assembly	R60-13.1Z
13.	Set Screw	STA 5602
14.	Key (no attachment drive)	STA 2011
15.	Slotted Screw f/motor mount plate	STA 5018
16.	Motor Mount Plate	R60-61.1E
18.	Mounting Bolt f/speed mechanism	STA 5345
19.	Washer	STA 6010
20.	Bolt f/motor mount plate	STA 5433
21.	Washer	STA 6026
22.	Nut f/rack	STA 5815
23.	Washers for spring fork	STA 6040
24.	Upper Fork.....	R20-19
25.	Jam Nut f/ low speed stop	STA 5810
26.	Bolt f/high speed stop	STA 5446
27.	Jam Nut f/ high speed stop.....	STA 5810
28.	Flanged Nut f/low speed stop	STA 5895
29.	Vari Spring	W40P-275
30.	Trestle.....	R20-26.1M4
31.	Pin Bolt f/low speed stop	AR81-305
32.	Washers for spring fork	STA 6040
33.	Flanged Nut f/low speed stop	STA 5810
34.	Lower Fork.....	R27-16M4
35.	Snap ring f/rack	STA 3407
36.	Rack	R15-46.0
37.	Bearing for Rack.....	R15-18.2
38.	Motor pulley shaft, assembly	R60-59Z
39.	Upper Pedestal Pulley	R60-13.1
40.	Snap Ring.....	STA 3410
41.	Pedestal Shaft for V80.....	R60-41Z
41A.	Pedestal Shaft for V100.....	RN100-41
42.	Key f/Pedestal Shaft	STA 2024
43.	Pulley f/Pedestal Shaft for V80.....	R100-128 (3V)
43A.	Pulley f/Pedestal Shaft for V100.....	RN100-128 (4V)
44.	Ball Bearing	6205 2RS
45.	Snap Ring.....	STA 3514
46.	Bolt	STA 5348
47.	Washer	STA 6033
48.	Pedestal Arm for V80.....	R100-6
48A.	Pedestal Arm for V100.....	R100-6
49.	Spacer	RN100-143
50.	Grease gun.....	R15-142
51.	Lower Pulley, assembly	R60-15.1Z
A.	Motor pulley assembly.....	R60-59.1Z
B.	Motor Pulley Bottom Half Assy	R60-13.1Z

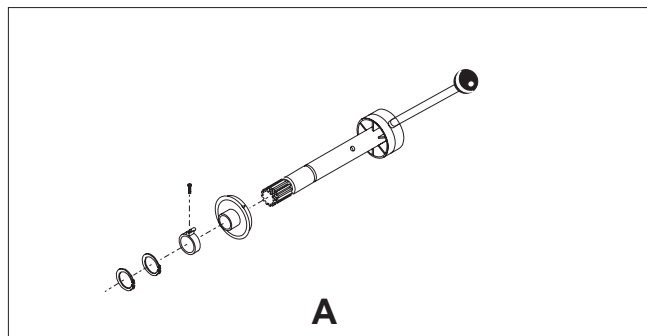
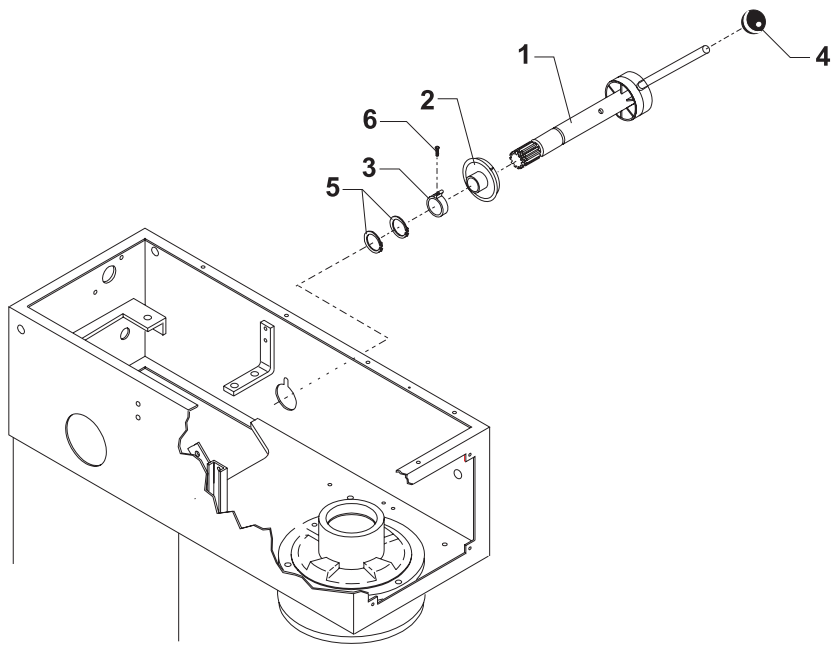

SPEED LEVER SYSTEM V80-V100

Fig.No	Description	V80 - V100
1.	Speed Lever W80.....	W81-47M
2.	Disc w/ arrow.....	AR30-47.10
3.	White Clamp.....	AR30-47.11
4.	Black Knob	STA 3306
5.	Snap Ring.....	STA 3414
6.	Screw.....	STA 5247
A	Lever assy.	AR81-47Z

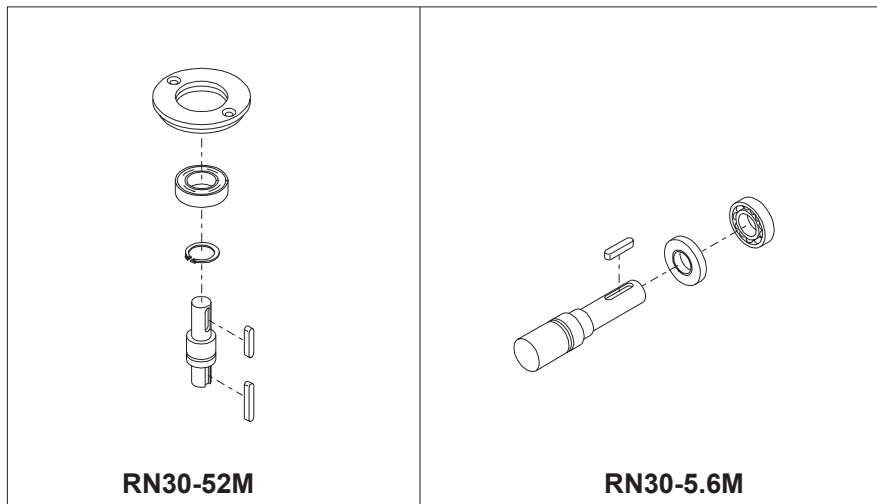
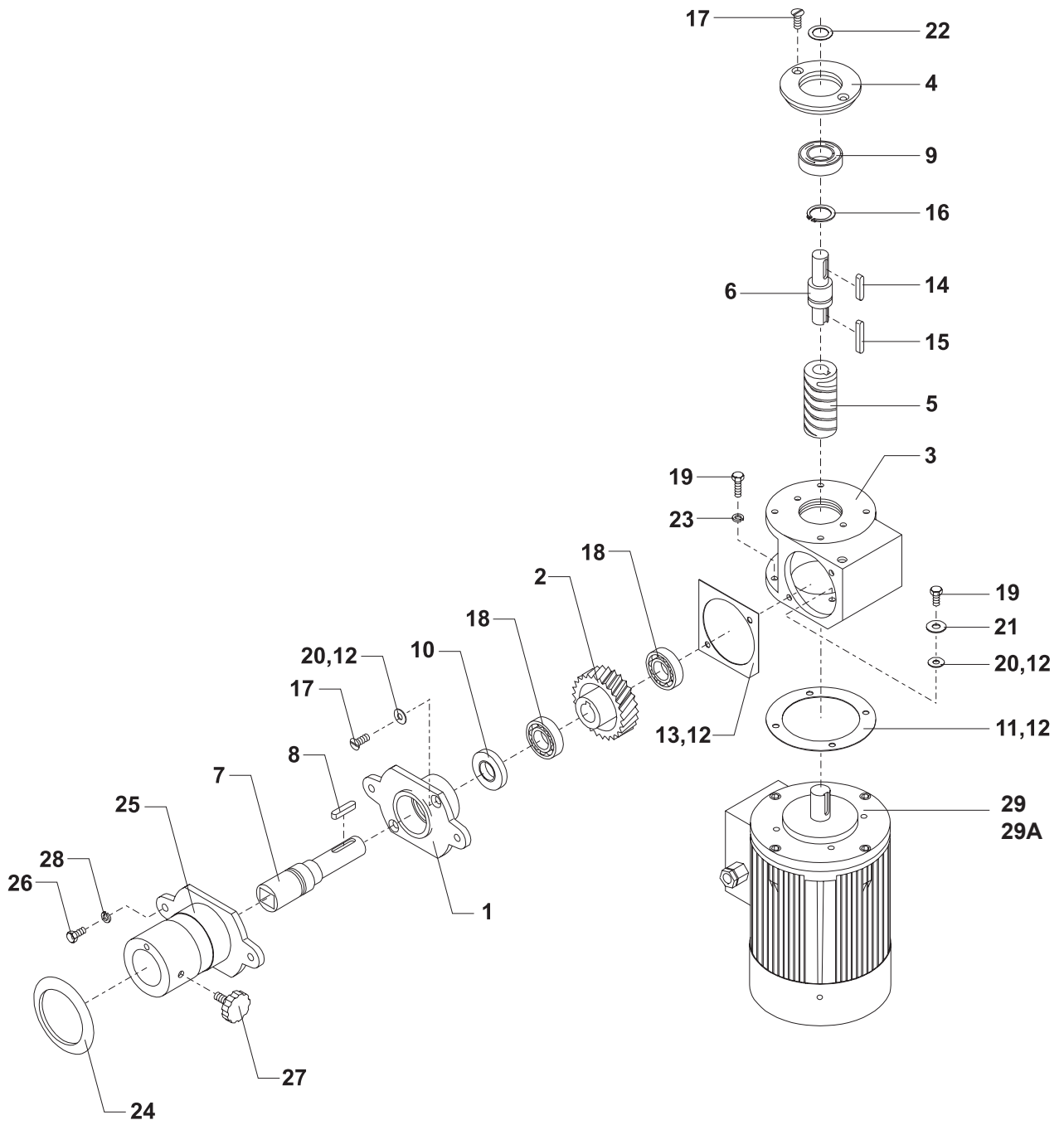

ATTACHMENT DRIVE GEARBOX - V80 ONLY

Fig.No	Description	V80
1.	Bearing Hub.....	R15-5
2.	Wormwheel.....	R20-9
3.	Gear Case	R15-10
4.	Gear Case Cover.....	R15-11
5.	Worm Gear.....	R20-49
6.	Gear Shaft	R20-52Z
7.	Attachment Drive Shaft # 12.....	R15-50.6
8.	Key	STA 2032
9.	Bearing	R20-104
10.	Seal	R20-107
11.	Gasket - Use RTV Silicone	R20-300
12.	Gasket - Use RTV Silicone	STA 5908
13.	Gasket - Use RTV Silicone	R20-301
14.	Key	STA 2007
15.	Key	STA 2011
16.	Snap Ring.....	STA 3410
17.	Screw.....	STA 5018
18.	Bearing	6005 2RS
19.	Bolt	STA 5433
20.	Seal Washer	STA 5908
21.	Washer	STA 6020
22.	Washer	STA 6054
23.	Lock Washer.....	STA6056
24.	Rubber Ring	R15-211
25.	Hub #12	R15-8.6M0
26.	Bolt	STA 5322
27.	Thumbscrew #12	4R-125
28.	Washer	STA 6056
29.	Motor 4HP 3 phase 208V	R100-85.52
29A.	Motor 4HP 3 phase 480V	R100-85.1

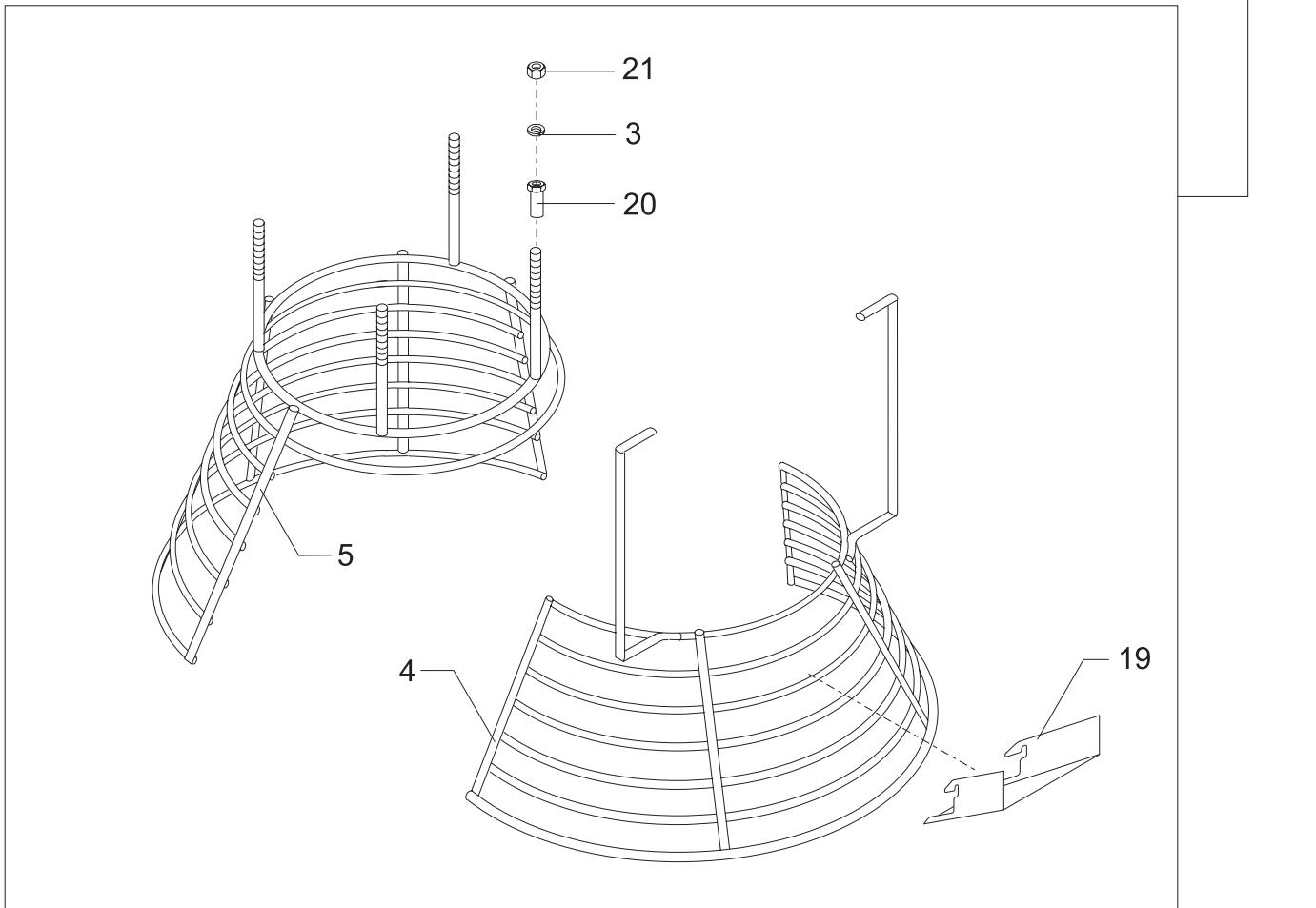
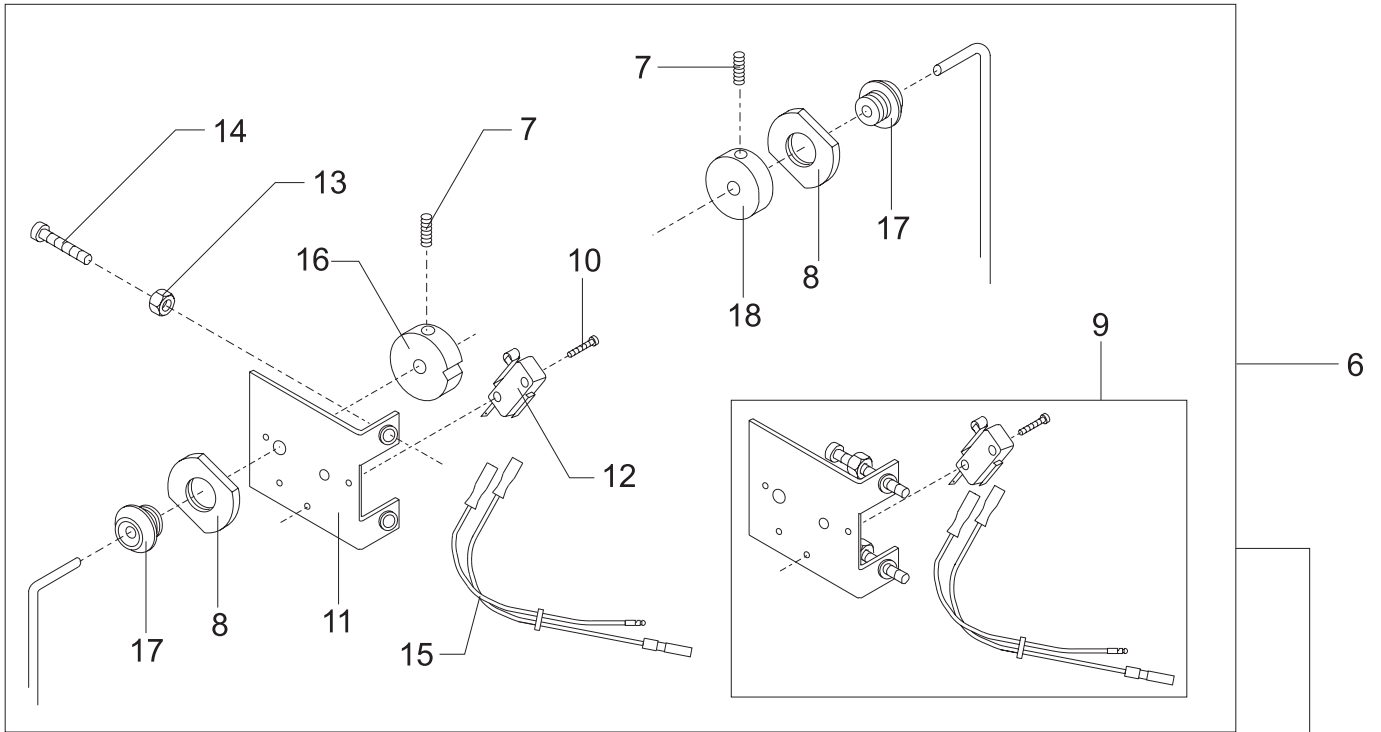

BOWL SCREEN V80-V100

Fig.No	Description	V80 - V100
1.	Bowl Screen Kit	14080-0001
3.	lockwasher.....	STA 6056
4.	Front bowl screen.....	56G81-21
5.	Rear bowl screen.....	56G81-22
6.	Fitting for bowl screen	56P60-75
7.	Set Screw f/keeper	STA 5665
8.	Nut f/ bushing	56SN60-24
9.	Microswitch bracket assembly.....	56P30-15
10.	Screw f/microswitch.....	STA 5251
11.	Bracket f/ microswitch.....	56SN30-13
12.	Microswitch.....	56SN20-30
13.	Nut.....	STA 5819
14.	Screw.....	STA 5250
15.	Cable for microswitch	AR30-193M
16.	Bowl Screen Cam notched.....	56SN30-22
17.	Bushing	56SN30-21
18.	Cam.....	56SN30-23
19.	Ingredient Chute	56G20-280
20.	Nut f/bowl screen adjustment	56G30-26
21.	Nut.....	STA 5810

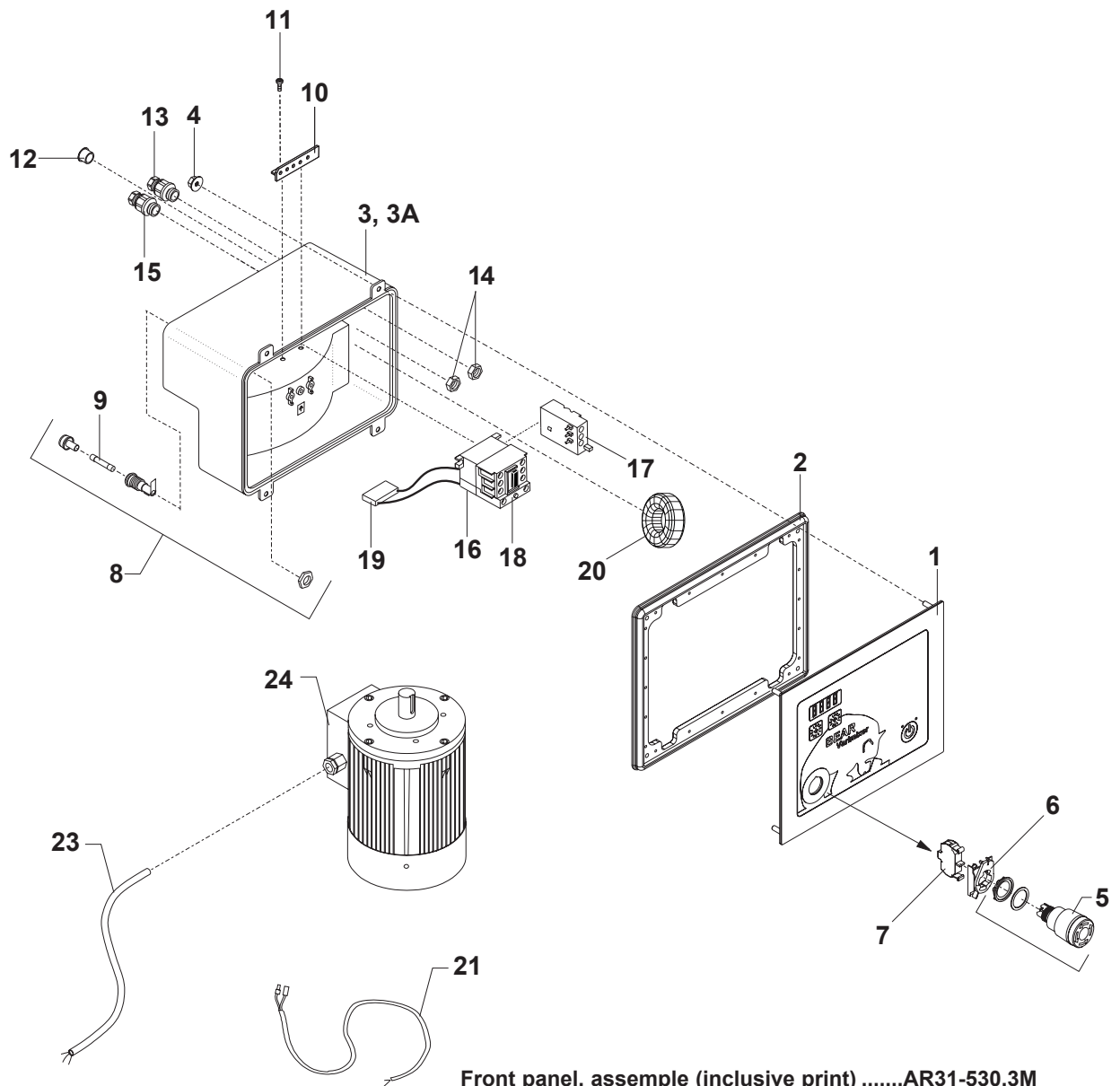

Front panel, assemple (inclusive print)AR31-530.3M
 Cover for front panel, assembly AR31-152.1Z

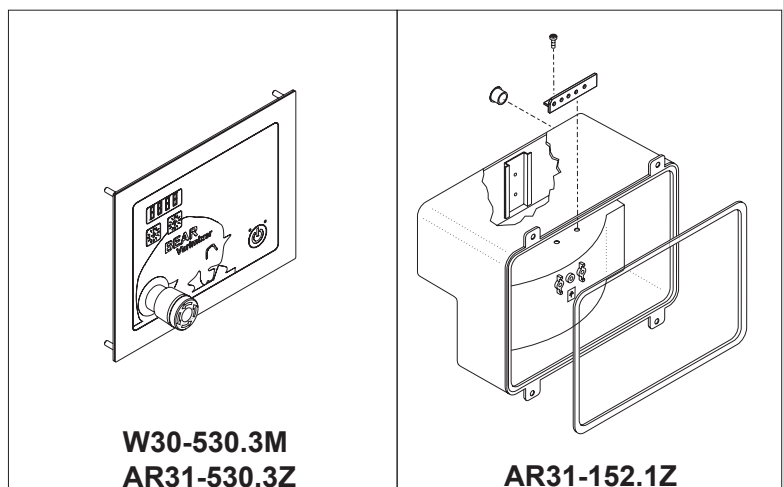
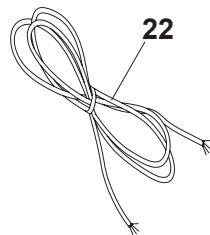

ELECTRICAL PANEL, MANUAL LIFT V80

Fig.No	Description	V80
1.	Front Panel VL1, assembly	AR31-530.3Z
2.	Gasket VL1 Front Panel	AR31-562V
3.	Cover for 3x208V	AR31-152.1Z
3A.	Cover for 3x480V	AR31-152.4
4.	Nut	STA 5897
5.	Emergency Stop Actuator	AR31-174.11
6.	Emergency Stop Adapter	AR31-174.12
7.	Contact Element NC	AR31-174.14
8.	Fuse Holder Complete	R20E-416.1
9.	Fuse 1.5A, Slow	R20E-418.2
10.	Grounding Clamp	AR31-458
11.	Screw	STA 5232
12.	Cover Button	STA 6519
13.	Cable Inlet	STA 3002
14.	Nut	STA 5801
15.	Cable Inlet only for 3x480V	STA 3118
16.	Contactor 3X208V, 3X480V	R100-88.8
17.	Thermal Overload 3X208V	R20-88.24
	Thermal Overload 3X480V	R20-88.22
18.	Auxiliary Switch 3X208V	R20-88.44
	Auxiliary Switch 3X480V	R20-88.47
19.	Capacitor 3x208V	AR31-85.320M
20.	Transformer 3x480V	AR10E-430
21.	Main Circuit Cable 3X208V, 3X480V	WR31-194.350M
22.	Lead Cable 3X208V	WR41-194.150M
	Lead Cable 3X480V	WR41-194.151M
23.	Motor Cable 3x208V	W41-194.250M
	Motor Cable 3x480V	W41-194.251M
24.	Motor 4HP 3x208V	R100-85.52
	Motor 4HP 3x480V	R100-85.1

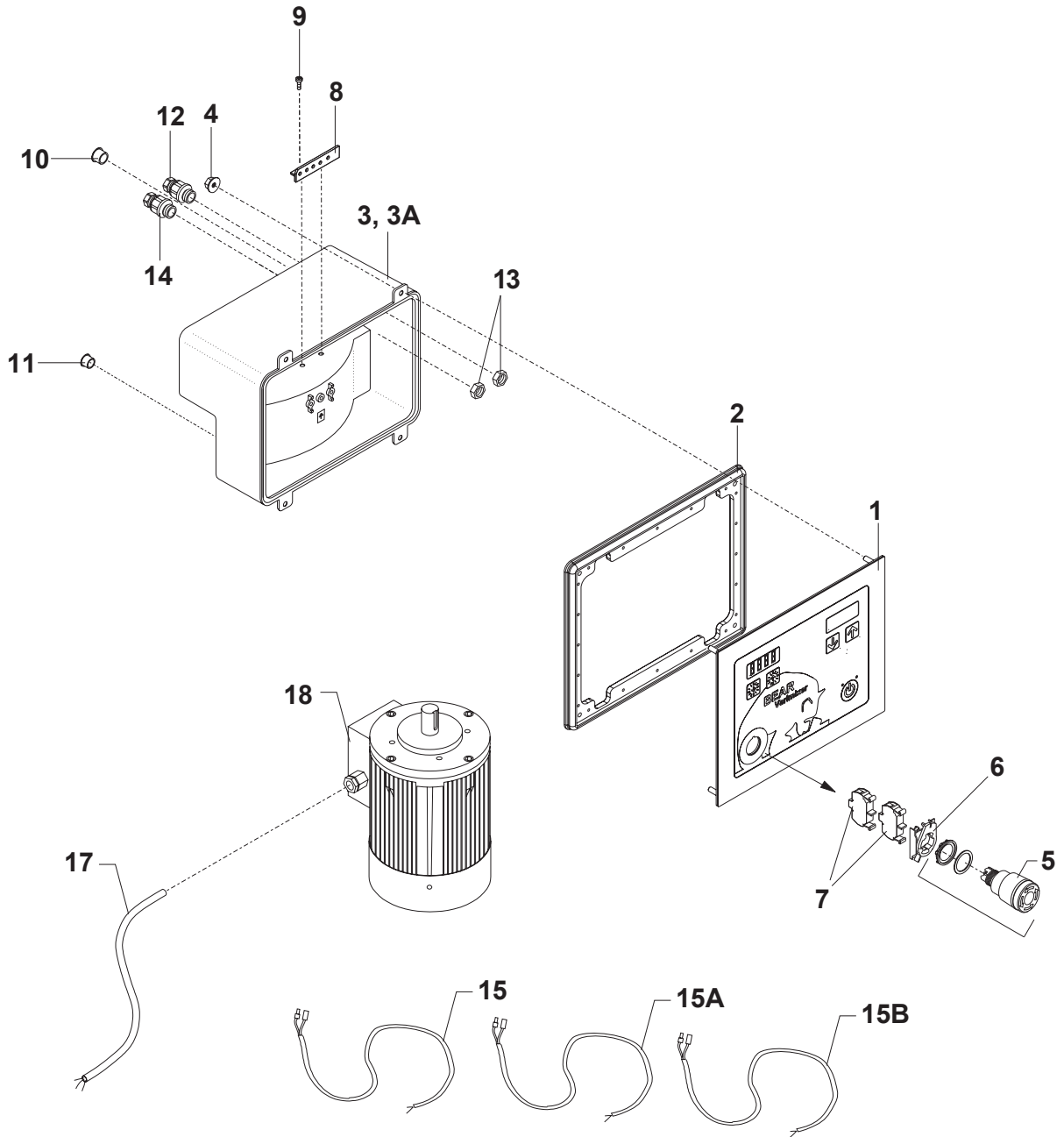

Front panel VL1L, assemple (inclusive print)AR31-530.6M
 Cover for front panel, assemblyAR31-152.1Z

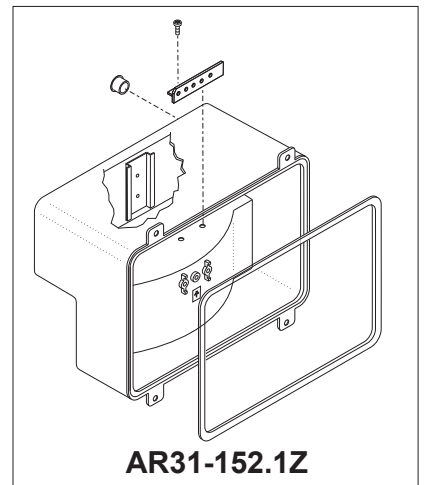
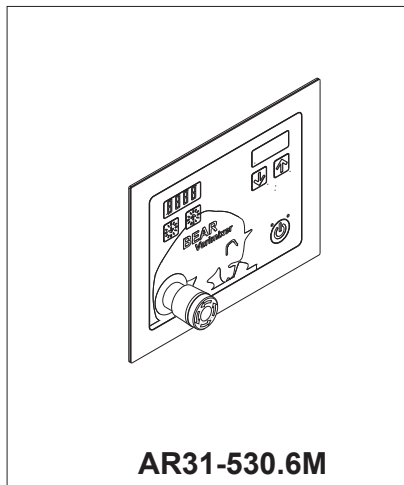
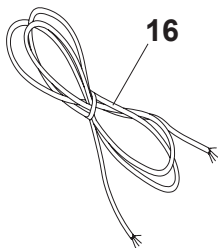

ELECTRICAL PANEL, POWER LIFT V80 -V100

<u>Fig.No</u>	<u>Description</u>	<u>V80 - V100</u>
1.	Front Panel VL1L, assembly	AR31-530.6M
2.	Gasket VL1 Front Panel.....	AR31-562
3.	Cover for 3x208V	AR31-152
3A.	Cover for 3x480V	AR31-152.4
4.	Nut.....	STA 5897
5.	Emergency Stop Actuator.....	AR31-174.11
6.	Emergency Stop Adapter	AR31-174.12
7.	Contact Element NC.....	AR31-174.14
8.	Grounding Clamp	AR31-458
9.	Screw.....	STA 5232
10.	Cover Button	STA 6519
11.	Cover Button	STA 6525
12.	Cable Inlet	STA 3002
13.	Nut	STA 5801
14.	Cable Inlet only for 3x480V	STA 3118
15.	Circuit Cable 3X208V, 3X480V	WR31-194.350M
15A.	Circuit Cable 3X208V, 3X480V	AR31-428.1
15B.	Circuit Cable 3X208V + 3X480V for V100PL.....	AR31-428
16.	Lead Cable 3X208V	WR41-194.150M
	Lead Cable 3X480V	WR41-194.151M
17.	Motor Cable 3x208V.....	W41-194.250M
	Motor Cable 3x480V.....	W41-194.251M
18.	Motor 4HP 3x208V	R100-85.52
	Motor 4HP 3x480V	R100-85.1

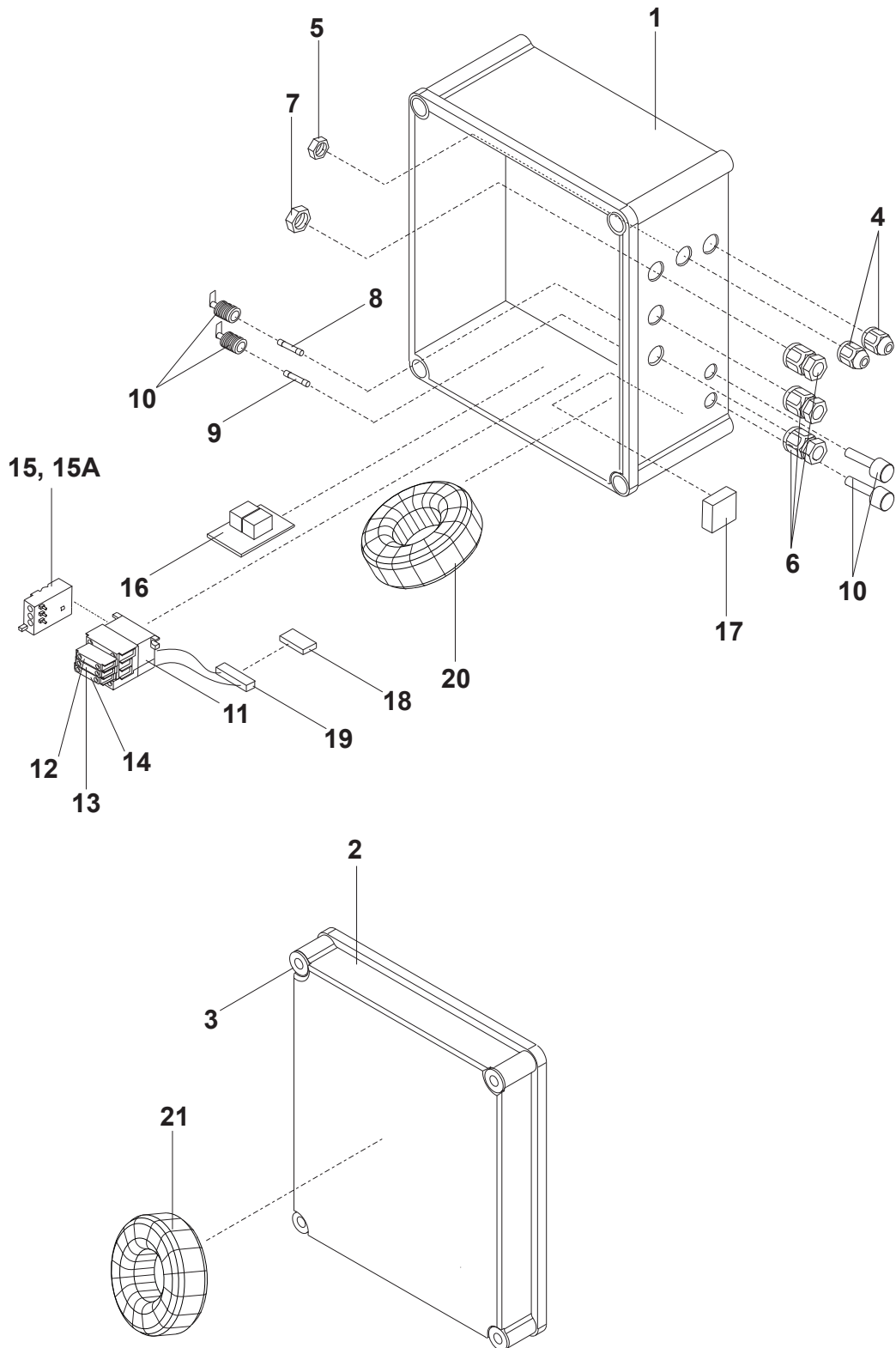

ELECTRICAL POWER SUPPLY V80-V100

<u>Fig.No</u>	<u>Description</u>	<u>V80 - V100</u>
1.	Power supply box.....	WR31-418
2.	Lid for Power supply box.....	WR31-418.1
3.	Screw for Power supply box.....	AR31-418.5
4.	Cable Inlet	STA 3074
5.	Nut.....	STA 3038
6.	Cable Inlet	STA 3002
7.	Nut.....	STA 3014
8.	Fuse 1.5A, slow.....	R20E-418.2
9.	Fuse 8A, slow.....	R20E-418.8
10.	Fuse holder	R20E-416.01
11.	Contactor 208V, 480V	R100-88.8
12.	Auxiliary Switch for LPC.....	R20-88.44
13.	Auxiliary Switch CB-NO, 3x480V	R20-88.47
14.	Auxiliary Switch CB-NC.....	R20-88.46
15.	Thermal Overload T116C 6-9.2	R20-88.22
15A.	Thermal Overload T116C 11-16	R20-88.24
16.	Overcurrent relay for Linak LA30	AR30-425
17.	Rectifier	R150E-425
18.	Relay 24Vdc 1P IDEC	AR140E-420
19.	Socket for relay IDEC.....	AR140E-421
20.	Transformer 230/24	R60E-430.1
21.	Transformer 400-480/230V 220VA.....	AR30E-430

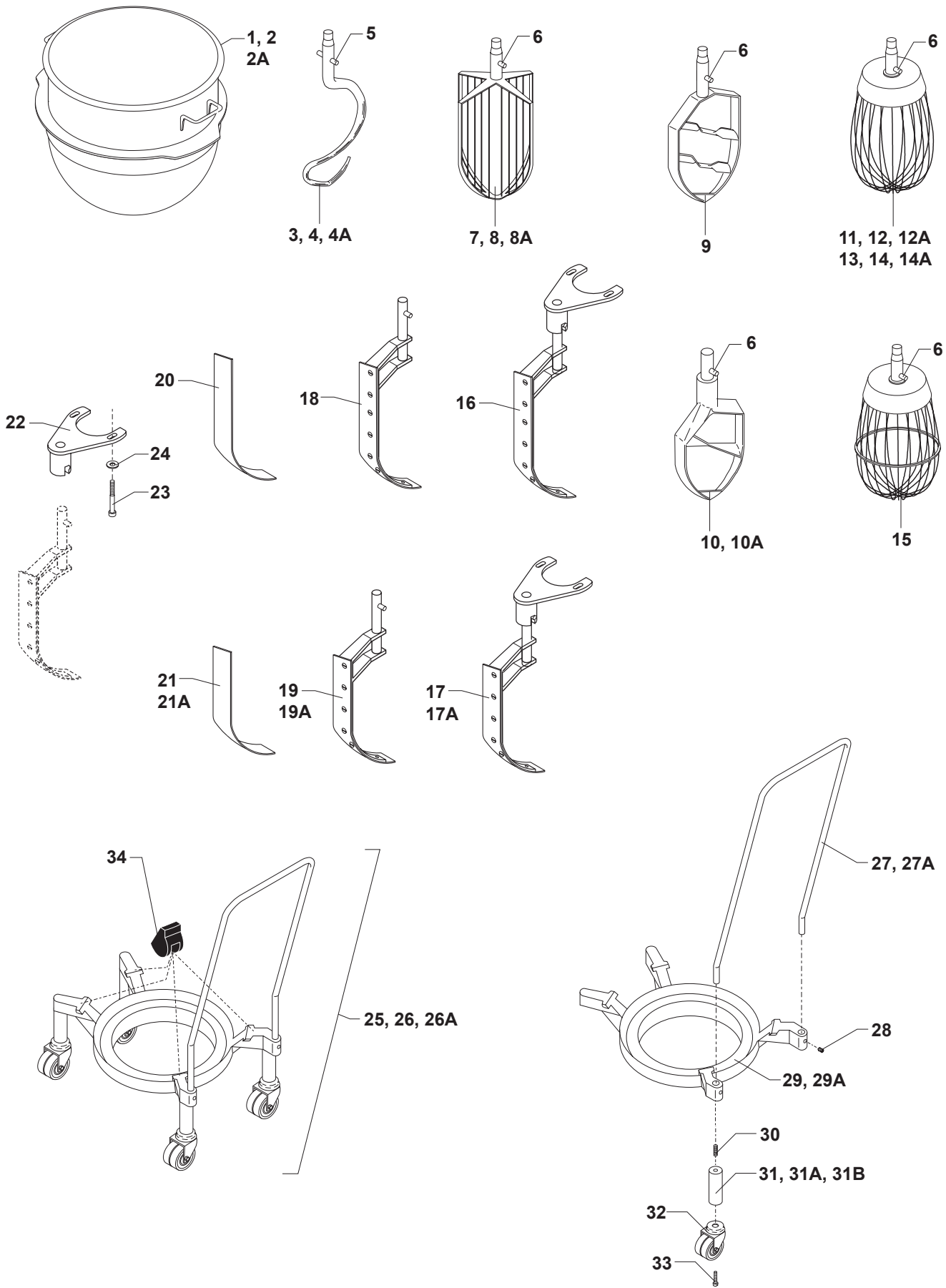

ATTACHMENTS AND OPTIONAL PRODUCTS

Fig.No	Description	V80	Sold As	V100	Sold As
1.	Stainless Steel Bowl (Standard).....	AR80-75M.....	VBOWL-80.....	RN100-75M.....	VBOWL-100
2.	Stainless Steel Bowl (Downsize 60).....	N/A.....	N/A.....	WN100-75AM.....	VBOWL60-100
2A.	Stainless Steel Bowl (Downsize 40).....	AR80-75AM.....	VBOWL40-80.....	WN100-75BM.....	VBOWL40-100
3.	Dough Hook (Double Pin).....	R100-78.5M.....	VHOOK-80.....	RN100-78.5M.....	VHOOK-100
4.	Dough Hook (Downsize 60).....	N/A.....	N/A.....	RN100-78.5AM.....	N/A
4A.	Dough Hook (Downsize 40, Double Pin).....	RN100-78BM.....	VHOOK40-100.....	RN100-78BM.....	VHOOK40-100
5.	Tool Pin (Double).....	AR60-79.....	N/A.....	AR60-79.....	N/A
6.	Tool Pin.....	STA 6263.....	N/A.....	STA 6263.....	N/A
7.	Wing Whip.....	14AR80.....	VWINGWHIP-80.....	14RN100.....	VWINGWHIP-100
8.	Wing Whip (Downsize 60).....	N/A.....	N/A.....	N/A.....	N/A
8A.	Wing Whip (Downsize 40).....	N/A.....	N/A.....	N/A.....	N/A
9.	Alu. Flat Beater (Double Pin).....	R100-18B2M.....	N/A.....	RN100-28.5M.....	VWHIP-100
10.	Flat Beater (Downsize 60, Aluminum).....	N/A.....	N/A.....	RN100-28A2M.....	N/A
10A.	Flat Beater (Downsize 40, Aluminum).....	RN100-28BM.....	VWHIP40-100.....	RN100-28BM.....	VWHIP40-100
11.	Wire Whip (Heavy Duty).....	N/A.....	N/A.....	N/A.....	N/A
12.	Wire Whip (Heavy Duty, Downsize 60).....	N/A.....	N/A.....	N/A.....	N/A
12A.	Wire Whip (Heavy Duty, Downsize 40).....	14RN100B.....	N/A.....	14RN100B.....	N/A
13.	S/S Wire Whip.....	AR80-28M.....	VWHIP-80.....	RN100-28.5M.....	VWHIP-100
14.	S/S Wire Whip (Downsize 60).....	N/A.....	N/A.....	RN100-27A2M.....	VBEAT60-100SS
14A.	S/S Wire Whip (Downsize 40).....	RN100-28BM.....	VWHIP40-100.....	RN100-28.B2M.....	N/A
15.	Wire Whip Reinforced.....	44AR80.....	VHDWHIP-80.....	44RN100.5FM.....	N/A
16.	Bowl Scaper.....	42AR80.....	VSCRIP-80.....	42RN100P.....	VSCRIP-100
17.	Bowl Scaper(downsize 60).....	N/A.....	N/A.....	42RN100AP.....	VSCRIP60-100
17A.	Bowl Scaper(downsize 40).....	224/40BN.....	VSCRIP40-100NH.....	42RN100BP.....	VSCRIP40-100
18.	Holder w/Blade.....	42AR80-202.....	N/A.....	42RN100-202.....	N/A
19.	Holder w/Blade (downsize 60).....	N/A.....	N/A.....	N/A.....	N/A
19A.	Holder w/Blade (downsize 40).....	42AR41A-202.....	VSCRIP20-40NH.....	42RN100B-202.....	VSCRIP40-80NH
20.	Nylon Blade.....	42AR80-204.....	N/A.....	42RN100-204.....	N/A
21.	Nylon Blade (downsize 60).....	N/A.....	N/A.....	N/A.....	N/A
21A.	Nylon Blade (downsize 40).....	42R40-204.....	N/A.....	42R40-204.....	N/A
22.	Scrapers Holder.....	42RN100-101M.....	N/A.....	42RN100-101M.....	N/A
23.	Screw.....	STA 6552.....	N/A.....	STA 6552.....	N/A
24.	Washer.....	STA 6029.....	N/A.....	STA 6029.....	N/A
25.	Bowl Truck.....	22WR80.....	VBTRUCK-80.....	22WN100.....	N/A
26.	Bowl Truck (Downsize Bowl 60).....	N/A.....	N/A.....	22WN100A.....	N/A
26A.	Bowl Truck (Downsize Bowl 40).....	22WR80A.....	N/A.....	22WN100B.....	N/A
27.	Bowl Truck Handle.....	22R271.....	N/A.....	22R271.....	N/A
27A.	Bowl Truck Handle (Downsize Bowl).....	22R277.....	N/A.....	22R277.....	N/A
28.	Set Screw.....	STA 5675.....	N/A.....	STA 5675.....	N/A
29.	Bowl Truck Frame.....	22R100-40.....	N/A.....	22R100-40.....	N/A
29A.	Bowl Truck Frame (Downsize Bowl).....	22R20-40.....	N/A.....	22R20-40.....	N/A
30.	Screw.....	STA 5608.....	N/A.....	STA 5608.....	N/A
31.	Spacer (For Standard Bowl).....	22R140.6.....	N/A.....	22R140.1-7W.....	N/A
31A.	Spacer (For Downsize Bowl 60).....	N/A.....	N/A.....	22R140.1-8W.....	N/A
31B.	Spacer (For Downsize Bowl 40).....	22R140.1-3W.....	N/A.....	22R140.1-8W.....	N/A
32.	Castor, Dual Wheel Bowl Truck.....	22R150-520.....	N/A.....	22R150-520.....	N/A
33.	Bolt.....	STA 5131.....	N/A.....	STA 5131.....	N/A
34.	Rubber Block (4 per bowl truck).....	30-206.....	N/A.....	30-206.....	N/A

Wiring Diagram V80 - with manuel Bowl Lift

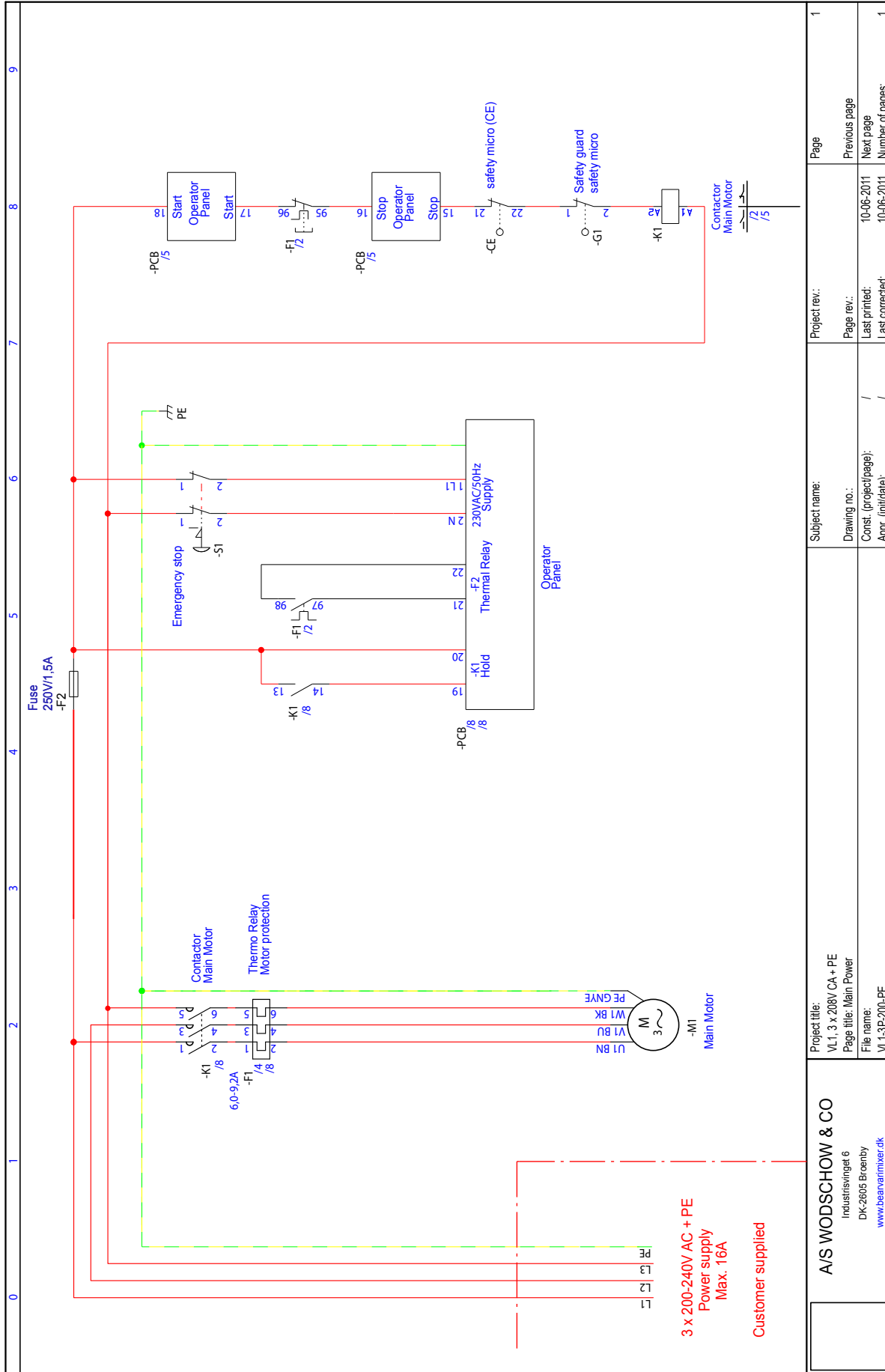

A/S WODSCHOW & CO Industrisvinget 6 DK-2605 Breeby www.beaunimixer.dk	Project title: VL1.3 x 208V CA + PE	Subject name: /	Project rev.: /	Page 1
	Page title: Main Power File name: VL1.3P-200-PE	Drawing no.: Const. (project/page): Appr. (initiate):	Page rev.: Last printed: Last corrected:	Page rev.: Last printed: Last corrected:

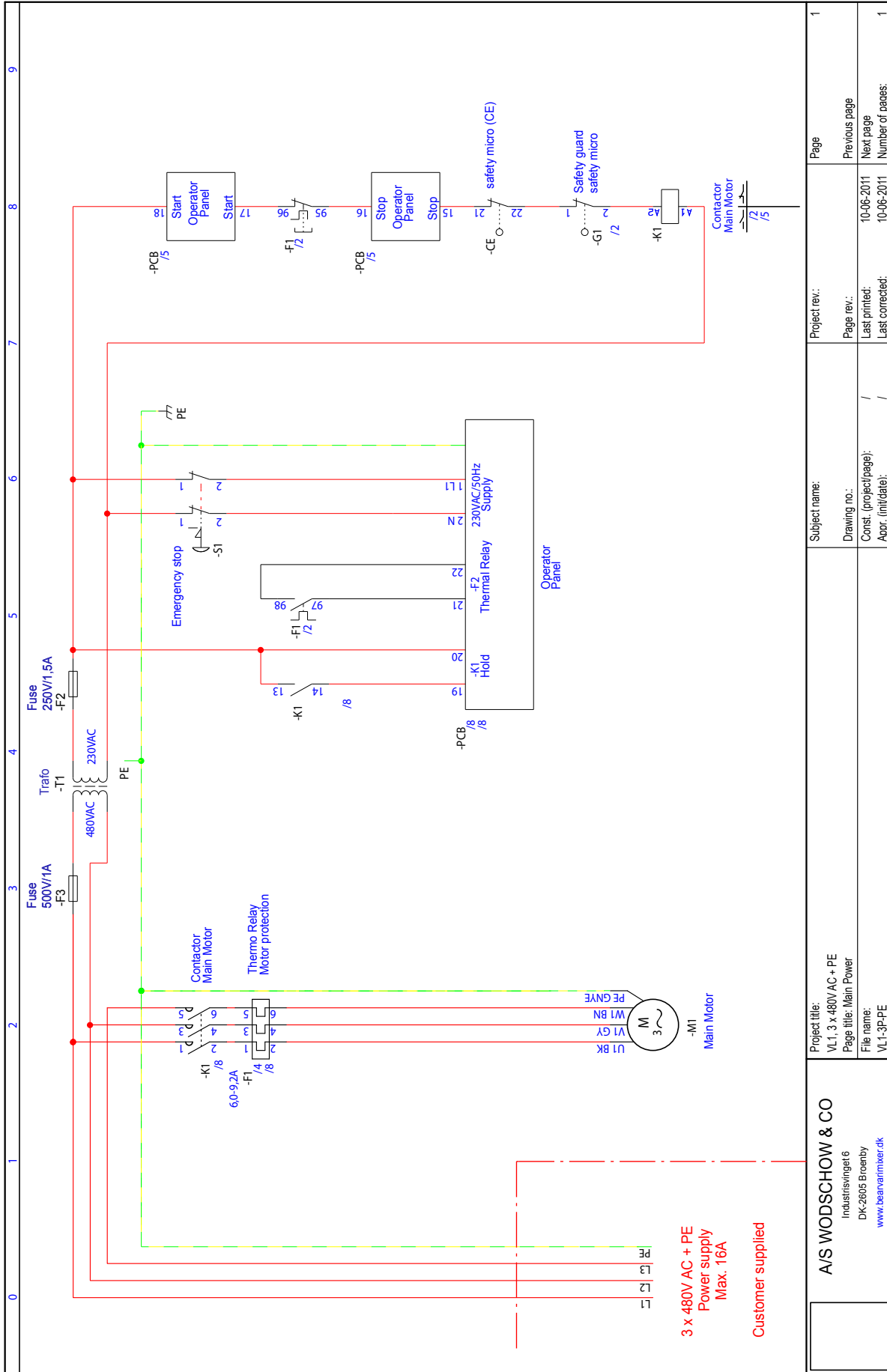



Varimixer

Varimixer
2215 East River Road
Dayton, OH 45439, US
P: (800) 222-1138
E: mixer@varimixer.com
www.varimixerusa.com