



Models Included

- WB5GT

**IMPORTANT**  
**CAUTION:** Equipment must be installed to comply with applicable federal, state, and local plumbing/electrical codes.

**IMPORTANT**  
**CAUTION:** Follow this setup procedure before attempting to use this unit. Failure to follow these instructions can result in injury and/or void of warranty.

**IMPORTANT**  
**CAUTION:** DO NOT connect the unit to hot water supply. The inlet valve is not rated for hot water.

**Important Safeguards/Symbols**

This equipment is designed for commercial use. Any servicing other than cleaning and routine maintenance should be performed by an authorized Wilbur Curtis Company service technician.

- DO NOT immerse the unit in water or any other liquid
- To reduce the risk of fire or electric shock, DO NOT open service panels. There are no user serviceable parts inside.
- Keep hands and other items away from hot areas of the unit during operation.
- Never clean with scouring powders or harsh chemicals.

**Symbols:**



**WARNINGS – To help avoid personal injury**



**Important Notes/Cautions – from the factory**



**Sanitation Requirements**

**INSTALLATION**

This Curtis unit is pre-set and ready to go from the factory.

**System Requirements:**

- Water Supply 20 – 90 PSI (MINIMUM FLOW RATE of 1 gpm)
- Electrical: See electrical schematic.

**SETUP STEPS**

1. The unit should be level (left to right - front to back), on a secure surface.
2. Connect the water line to the water inlet fitting on the rear of the unit. Water volume going to the machine should be consistent. Use tubing sized sufficiently to provide a minimum flow rate of one gallon per minute.

*NOTE: A water filtration system must be used to help maintain trouble-free operation. In areas with extremely hard water, we highly recommend the use of a Curtis approved water filter. (For our full line of filters, please log on to [www.wilburcurtis.com](http://www.wilburcurtis.com)) A water filtration system will greatly prolong the life of the unit and enhance the quality and taste of the product.*



*NSF requires the following water connection:*

1. A quick disconnect or additional coiled tubing (at least 2x the depth of the unit) is required so that the unit can be moved for cleaning.
2. This unit must be installed with adequate backflow protection to comply with applicable federal, state and local codes.
3. Water pipe connections and fixtures directly connected to a portable water supply shall be sized, installed and maintained in accordance with federal, state, and local codes.

3. Connect the unit to electrical outlet with appropriate amperage rating (See serial tag on machine).
4. Once power has been supplied to the unit, flip the toggle switch to the 'ON' position (located on the rear of the unit), the water tank will begin to fill. When the water level in the tank reaches the probe, the heating element will turn on.
5. Water in the heating tank will require 60 to 70 minutes before reaching operating temperature (factory setting of 204°F).

**WB5GT  
Rough-In  
Drawing**

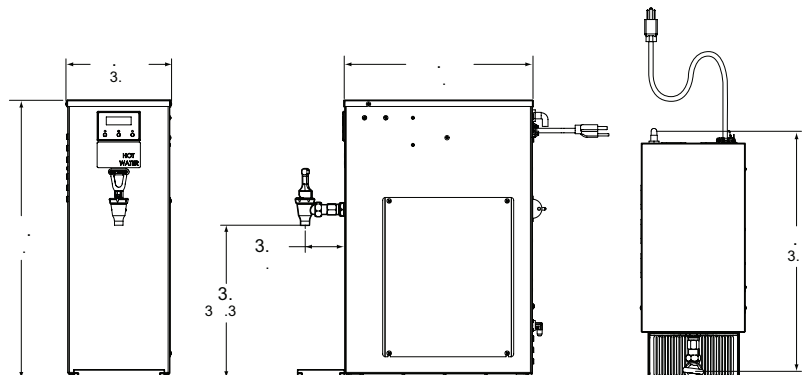

ISO 9001:2008 REGISTERED

WILBUR CURTIS CO.  
 6913 Acco Street,  
 Montebello, CA 90640-5403  
 For the latest information go to  
[www.wilburcurtis.com](http://www.wilburcurtis.com)  
 Tel: 800/421-6150  
 Fax: 323/837-2410



# PROGRAMMING

## UNIVERSAL CONTROL MODULE (UCM)

### A FUNCTION

1. Press **TEMP** button for **1** second to check the set point temperature.
2. Press **TEMP** button for **3** seconds to enter heating tank temperature programming mode. The temperature in the heating tank is adjustable from 140° to 210° F.

To change temperature setting:

- a. Press  to increase at 2° increments.
- b. Press  to decrease temperature.
- c. Press  to set and exit programming.

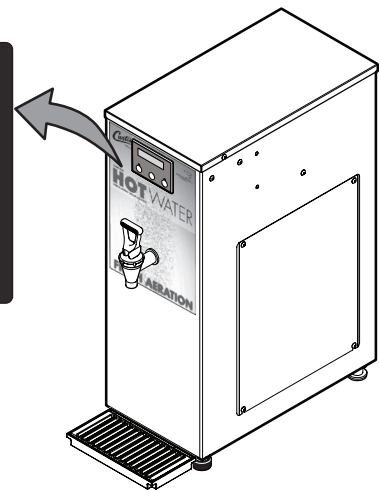
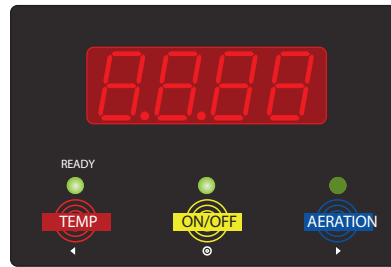

### B FUNCTION

1. Press the **AERATION** button to pump air through the water in the heating tank.
2. Aerator pump will run as long as you hold down the button. Release button to stop.

### I/O FUNCTION

1. **ON/OFF** button. Press once to activate control panel.
2. **ON/OFF** button used to set and exit programming.

## OTHER FEATURES

### LED SCREEN DISPLAY

When the unit is on and not in programming mode, the UCM will stay on and the LED screen will display the current tank temperature. The factory setting is 204°F. In the UCM programming, there is an option to change the screen display to read **HOT** instead of the set point temperature. You may also change the temperature units from Fahrenheit to Celsius.

To Change the LED To Read **HOT**:

1. Press the left **TEMP** button and hold down for **5** seconds. The **F** will start flashing.
2. Continue holding the **TEMP** button, at the same time, press and hold the **ON/OFF** button for **5** seconds.
3. Release both buttons. The program is now changed and the LED screen will display **HOT**.
4. While in the **HOT** display, pressing the **TEMP** button for 1 second will display the tank temperature.

To Change the LED To Read In Celsius:

1. Press and hold down the **TEMP** button for **10** seconds. The temperature reading will change to Celsius.
2. Release the **TEMP** button. The LED screen will display the temperature in degrees Celsius (default is 96°C).

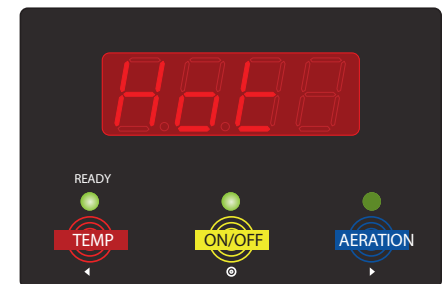
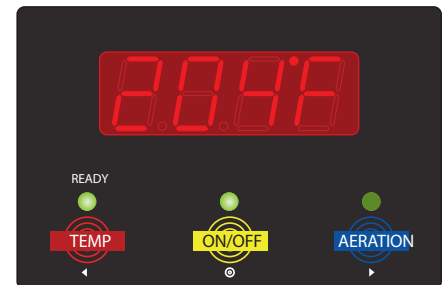

### AERATOR

The aerator pump will automatically come on every 30 minutes. Aeration is factory set to run for 5 seconds. When the aeration is running, the display shows the LED bars chasing from left to right.

### ERROR CODES

ERR1 = Overflow. Water level error.

ERR2 = Open sensor. Break in temperature thermistor circuit.

# ILLUSTRATED PARTS LIST

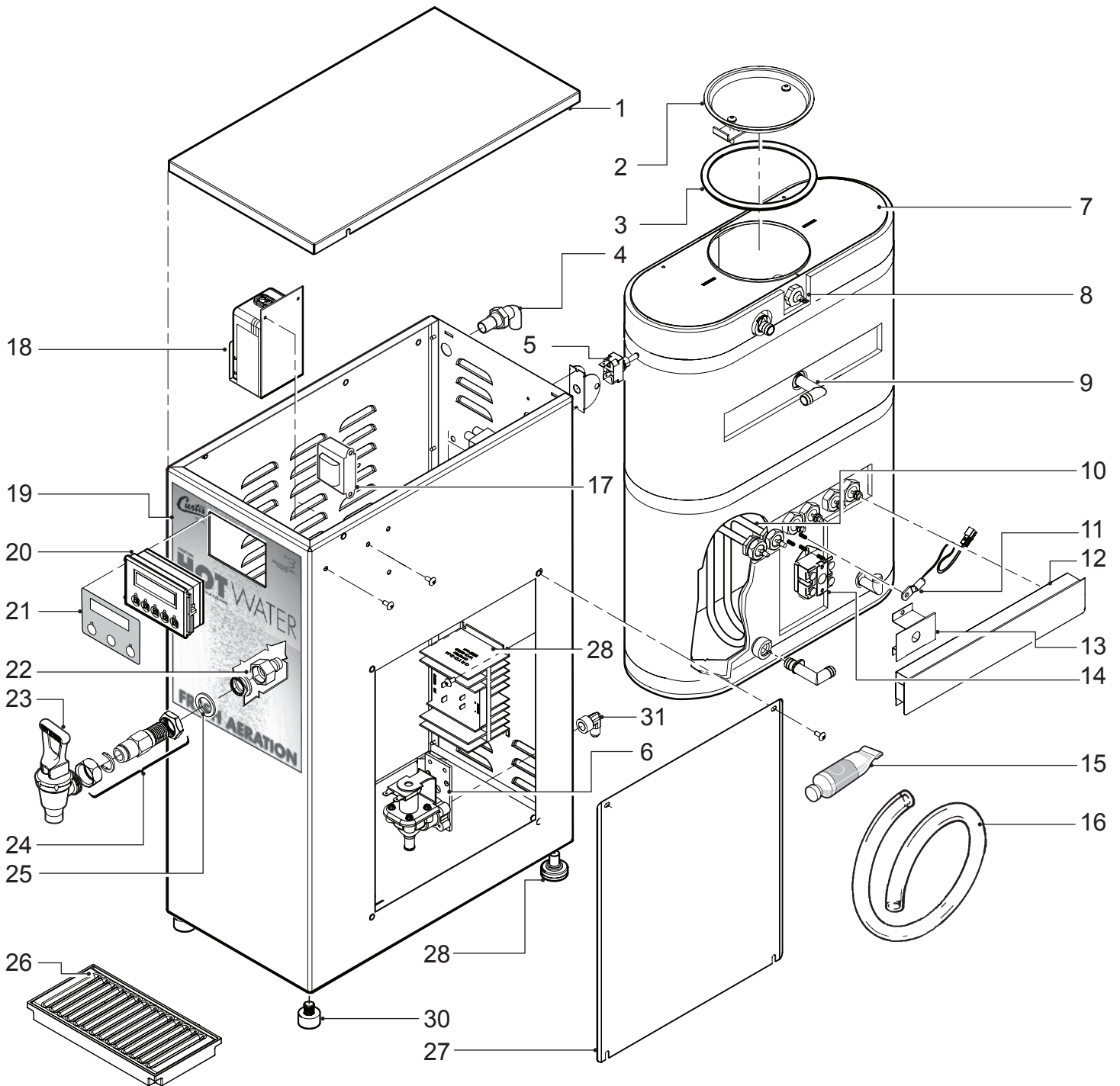

## PARTS LIST

ITEM Nº	PART Nº	DESCRIPTION
1	WC-58117	TOP COVER
2	WC-5661	LID ASSY, TANK
3	WC-43067*	O' RING, 4-1/2 I.D. x Ø.285 SILICONE
4	WC-2948	FITTING, TANK OVERFLOW NICKEL PLATED
5	WC- 102*	SWITCH, TOGGLE NON-LIT SPST 25A 125/250VAC
6	WC-826L*	VALVE, INLET 1.15GPM 120VAC 10W
7	WC-62045	TANK, COMPLETE WB5GT63
7A	WC-62044	TANK, COMPLETE WB5GT19
8	WC-5521*	PROBE, ASSY LIQUID LEVEL ULTEM
9	WC-29047	ELBOW, OVERFLOW PLASTIC ULTEM (8mm)
10	WC- 934-04*	HEATING ELEMENT, 220V 2500W
11	WC-1438-101*	SENSOR, TEMPERATURE TANK
12	WC-4382*	GUARD, SHOCK HTNG ELMNT DOUBLE
13	WC-43055	GUARD, SHOCK RESET THERMOSTAT
14	WC- 522*	THERMOSTAT, HI LIMIT HTR CNTRL DPST 277V 40A
15	WC-5231*	COMPOUND, SILICONE 5 oz
16	WC-5310*	TUBING, 5/16" ID X 1/8" W SILICONE
17	WC- 718*	TRANSFORMER, 120VAC-12VAC
17A	WC- 719*	TRANSFORMER, 240/120VAC-12VAC
18	WC-1048-101*	PUMP, ASSY AGITATION WB5GT
19	WC-39610	LABEL, FRONT OUTER
20	WC- 794*	CONTROL MODULE, 120V MINI WB
21	WC-39602	LABEL, MUCM CONTROL PANEL
22	WC-29082	FITTING, 1/2"-14 NPSF ASSEMBLY
23	WC-1866HW*	FAUCET, LOCKING HOT WATER
24	WC-1902	SHANK, FAUCET PLAIN W/NUTS
25	WC-1813	WASHER, 1 1/8" O.D.
26	DTP-08	DRIP TRAY ASSEMBLY
27	WC-61549	COVER, SIDE ACCESS
28	WC-3518*	LEG, GLIDE 3/8"-16 STUD SCREW
29	WC-8559*	RELAY, SOLID STATE W/INTEGRATED HT SINK
30	WC-3503*	LEG, 3/8"-16 STUD SCREW BUMPER
31	WC-2401	ELBOW, 3/8 NPT x 1/4 FLARE PLTD

\* SUGGESTED PARTS TO STOCK

# ELECTRICAL SCHEMATIC 120/220V SINGLE PHASE

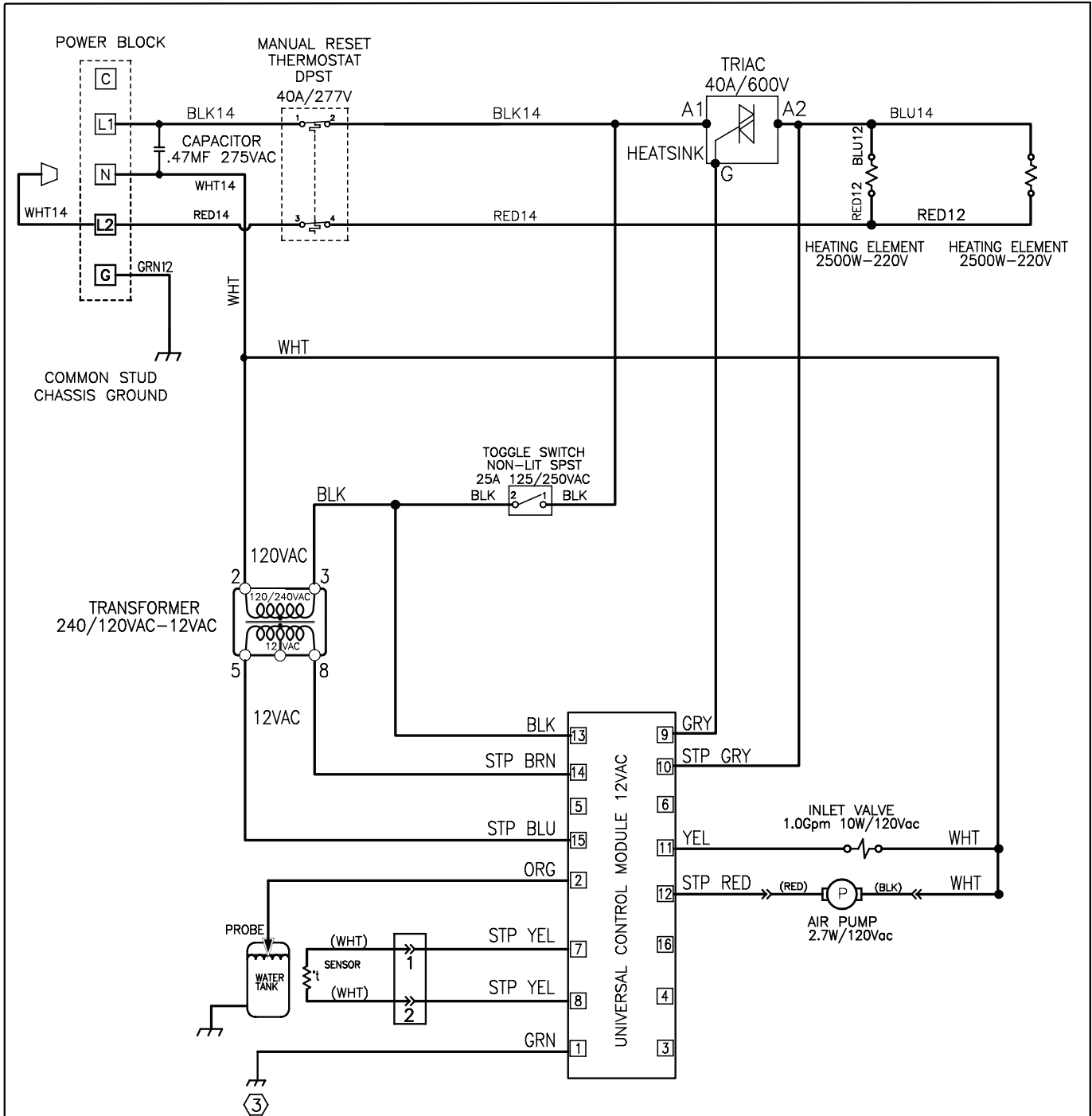

## MUCM PIN ASSIGNMENTS

PIN ASSIGNMENTS
PIN 01: GROUND
PIN 02: LEVEL PROBE
PIN 03: NOT USED
PIN 04: NOT USED
PIN 05: SSR (+5Vdc)
PIN 06: NOT USED
PIN 07: TEMP SENSOR
PIN 08: TEMP SENSOR
PIN 09: TRIAC GATE
PIN 10: TRIAC RETURN A2
PIN 11: INLET VALVE
PIN 12: AIR PUMP
PIN 13: 120Vac HOT (BLK)
PIN 14: 12V TRANSFORMER
PIN 15: 12V TRANSFORMER
PIN 16: SSR (0V)

## TRIAC PIN ASSIGNMENTS

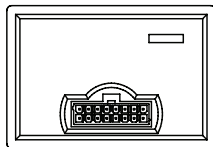
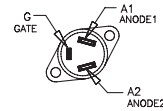

- FOR USE WITH 120V: REMOVE CAP FROM JUMPER & CONNECT TO POINT N ON TERMINAL BLOCK. FOR USE WITH 220V (FACTORY DEFAULT): JUMPER TO BE DISCONNECTED AND CAPPED.
- INSTALL A GROUND WIRE ASSEMBLY FROM THE HARNESS TO THE SEPARATE GROUND STUD ON TANK.
- DO NOT CHANGE NOR SUBSTITUTE WIRE COLORS.
- ALL WIRES SHALL BE 18 AWG MINIMUM.

NOTES: UNLESS OTHERWISE SPECIFIED

Voltage	Wattage	Amp	Voltage	Model Number	Title
120Vac	1500W	12.5A	120/220VAC	WB5GT63	LADDER DIAGRAM WB5GT 120/220V
220Vac	5000W	22.7A	WATTAGE: 1500/5000W AMPENAGE: 12.5/22.7A HERTZ: 50/60Hz WRES: 2W/3W + GND PHASE: 1 PHASE	DRAWN BY: JY DATE: 04/20/07	PART NUMBER: LD-WB5GT-63 REVISION: A

# ELECTRICAL SCHEMATIC 220V THREE PHASE

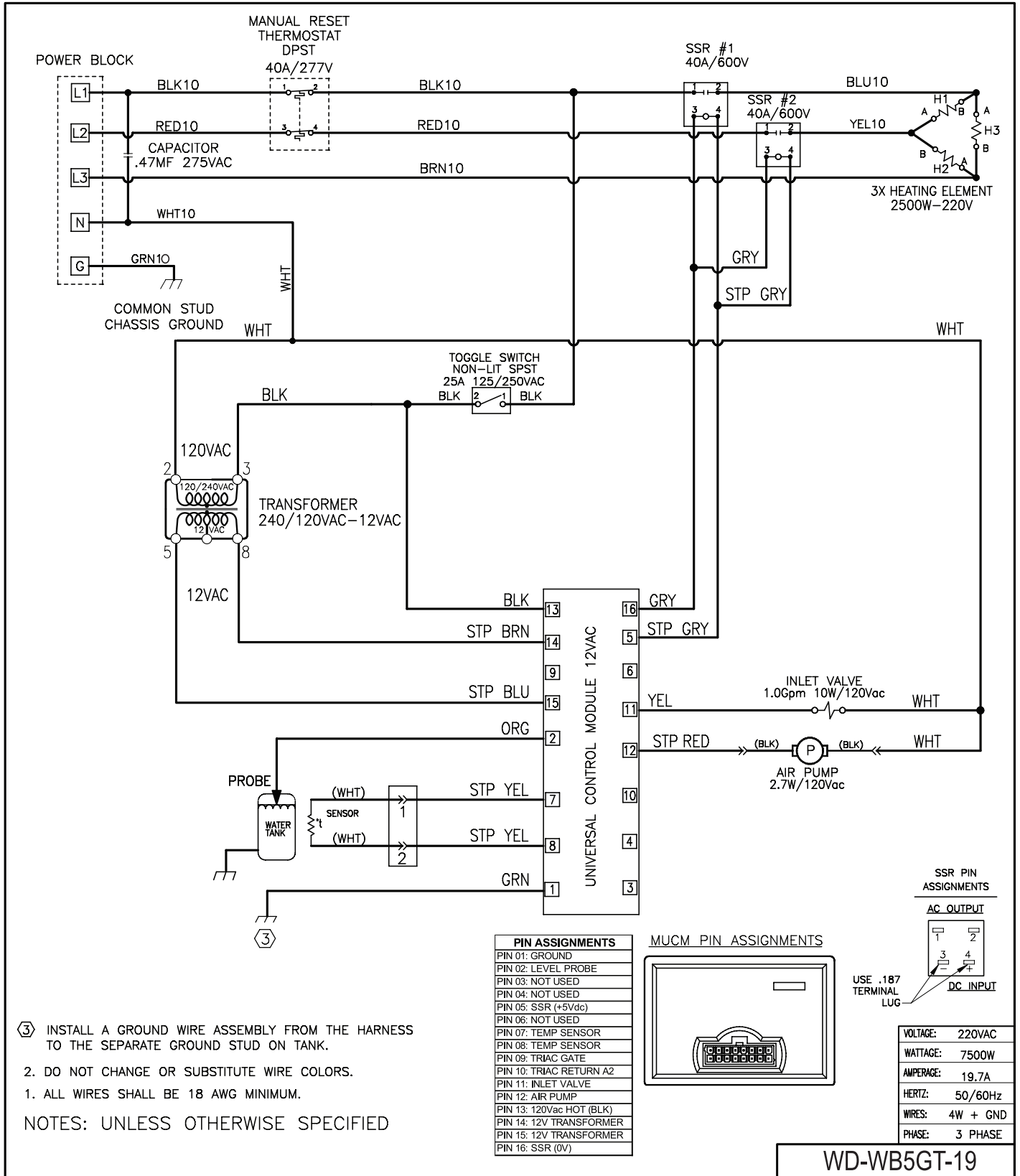

- ③ INSTALL A GROUND WIRE ASSEMBLY FROM THE HARNESS TO THE SEPARATE GROUND STUD ON TANK.
- DO NOT CHANGE OR SUBSTITUTE WIRE COLORS.
  - ALL WIRES SHALL BE 18 AWG MINIMUM.
- NOTES: UNLESS OTHERWISE SPECIFIED

PIN ASSIGNMENTS	
PIN 01:	GROUND
PIN 02:	LEVEL PROBE
PIN 03:	NOT USED
PIN 04:	NOT USED
PIN 05:	SSR (+5Vdc)
PIN 06:	NOT USED
PIN 07:	TEMP SENSOR
PIN 08:	TEMP SENSOR
PIN 09:	TRIAC GATE
PIN 10:	TRIAC RETURN A2
PIN 11:	INLET VALVE
PIN 12:	AIR PUMP
PIN 13:	120Vac HOT (BLK)
PIN 14:	12V TRANSFORMER
PIN 15:	12V TRANSFORMER
PIN 16:	SSR (0V)

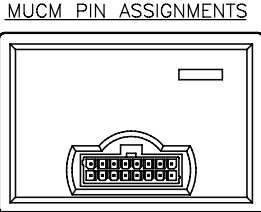

SSR PIN ASSIGNMENTS

AC OUTPUT

USE .187 TERMINAL LUG

VOLTAGE:	220VAC
WATTAGE:	7500W
AMPERAGE:	19.7A
HERTZ:	50/60Hz
WIRES:	4W + GND
PHASE:	3 PHASE

**WD-WB5GT-19**

## WALL MOUNT OPTION

This wall mount kit allows you to place your Curtis water boiler, model WB5GT, against a wall surface. The water boiler may be mounted with the faucet facing in either direction. The kit requires some assembly. To order the kit request Curtis part number WC-37347.

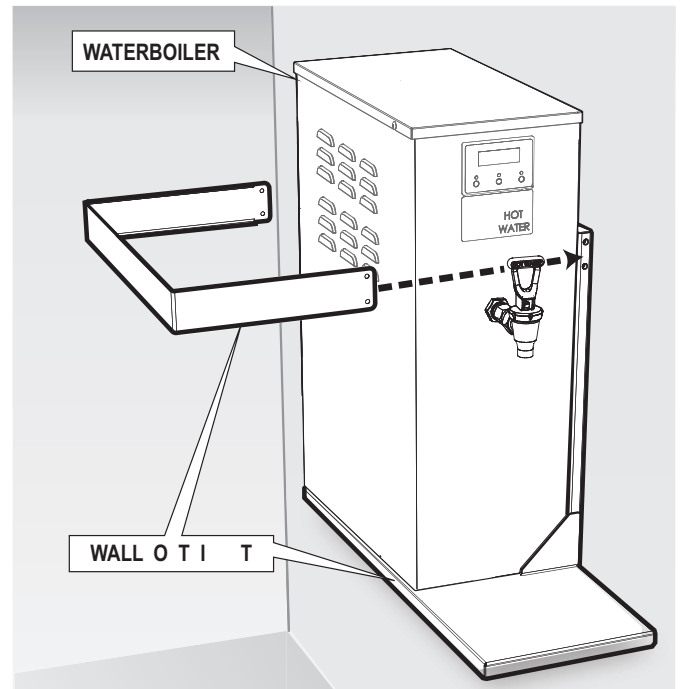



## Product Warranty Information

The Wilbur Curtis Company certifies that its products are free from defects in material and workmanship under normal use. The following limited warranties and conditions apply:

3 Years, Parts and Labor, from Original Date of Purchase on digital control boards.

2 Years, Parts, from Original Date of Purchase on all other electrical components, fittings and tubing.

1 Year, Labor, from Original Date of Purchase on all electrical components, fittings and tubing.

Additionally, the Wilbur Curtis Company warrants its Grinding Burrs for Forty (40) months from date of purchase or 40,000 pounds of coffee, whichever comes first. Stainless Steel components are warranted for two (2) years from date of purchase against leaking or pitting and replacement parts are warranted for ninety (90) days from date of purchase or for the remainder of the limited warranty period in which the component is installed.

All in-warranty service calls must have prior authorization. For Authorization, call the Technical Support Department at 1-800-995-0417. Effective date of this policy is April 1, 2003.

Additional conditions may apply. Go to [www.wilburcurtis.com](http://www.wilburcurtis.com) to view the full product warranty information.

### CONDITIONS & EXCEPTIONS

The warranty covers original equipment at time of purchase only. The Wilbur Curtis Company, Inc., assumes no responsibility for substitute replacement parts installed on Curtis equipment that have not been purchased from the Wilbur Curtis Company, Inc. The Wilbur Curtis Company will not accept any responsibility if the following conditions are not met. The warranty does not cover and is void under the following circumstances:

- 1) Improper operation of equipment: The equipment must be used for its designed and intended purpose and function.
- 2) Improper installation of equipment: This equipment must be installed by a professional technician and must comply with all local electrical, mechanical and plumbing codes.
- 3) Improper voltage: Equipment must be installed at the voltage stated on the serial plate supplied with this equipment.
- 4) Improper water supply: This includes, but is not limited to, excessive or low water pressure, and inadequate or fluctuating water flow rate.
- 5) Adjustments and cleaning: The resetting of safety thermostats and circuit breakers, programming and temperature adjustments are the responsibility of the equipment owner. The owner is responsible for proper cleaning and regular maintenance of this equipment.
- 6) Damaged in transit: Equipment damaged in transit is the responsibility of the freight company and a claim should be made with the carrier.
- 7) Abuse or neglect (including failure to periodically clean or remove lime accumulations): Manufacturer is not responsible for variation in equipment operation due to excessive lime or local water conditions. The equipment must be maintained according to the manufacturer's recommendations.
- 8) Replacement of items subject to normal use and wear: This shall include, but is not limited to, light bulbs, shear disks, "O" rings, gaskets, silicone tube, canister assemblies, whipper chambers and plates, mixing bowls, agitation assemblies and whipper propellers.
- 9) Repairs and/or Replacements are subject to our decision that the workmanship or parts were faulty and the defects showed up under normal use. All labor shall be performed during regular working hours. Overtime charges are the responsibility of the owner. Charges incurred by delays, waiting time, or operating restrictions that hinder the service technician's ability to perform service is the responsibility of the owner of the equipment. This includes institutional and correctional facilities. The Wilbur Curtis Company will allow up to 100 miles, round trip, per in-warranty service call.

RETURN MERCHANDISE AUTHORIZATION: All claims under this warranty must be submitted to the Wilbur Curtis Company Technical Support Department prior to performing any repair work or return of this equipment to the factory. All returned equipment must be repackaged properly in the original carton. No units will be accepted if they are damaged in transit due to improper packaging. NO UNITS OR PARTS WILL BE ACCEPTED WITHOUT A RETURN MERCHANDISE AUTHORIZATION (RMA). RMA NUMBER MUST BE MARKED ON THE CARTON OR SHIPPING LABEL. All in-warranty service calls must be performed by an authorized service agent. Call the Wilbur Curtis Technical Support Department to find an agent near you.

ECN 13065 . 3/30/11 @ 10.0  
ECN 13026 . 3/9/11 @ 16.0  
ecn 10504 . 7/13/9 @ 13.8  
ecn xxx . 8/20/8 @ 13.1  
ecn 9868 . 7/18/8 @ 15.3  
ECN 9068 . 10/16/7 @ 15.5  
EDR 4964 4/27/7 @ 10.3



#### WILBUR CURTIS CO., INC.

6913 Acco St., Montebello, CA 90640-5403 USA

Phone: 800/421-6150 ♦ Fax: 323-837-2410

♦ Technical Support Phone: 800/995-0417 (M-F 5:30A - 4:00P PST) ♦ E-Mail: [techsupport@wilburcurtis.com](mailto:techsupport@wilburcurtis.com)

♦ Web Site: [www.wilburcurtis.com](http://www.wilburcurtis.com)

FOR THE LATEST SPECIFICATION INFORMATION GO TO [WWW.WILBURCURTIS.COM](http://WWW.WILBURCURTIS.COM)