



Atlas Metal

INDUSTRIES, INC.

A subsidiary of Mercury Aircraft, Inc

1135 N.W. 159th DRIVE, MIAMI, FLORIDA 33169

TEL.: (305) 625-2451 TOLL FREE (800) 762-7565 FAX: (305) 623-0475

COLD PAN REFRIGERATED AIR FLOW SYSTEM WCM-BT SERIES

Service and Installation Manual

Please read this manual completely before attempting to install or operate this equipment!
Notify carrier of damage! Inspect all components immediately. See page 1.



**DROP-IN COLD PAN
REFRIGERATED, AIR FLOW SYSTEM
SELF-CONTAINED WITH DEFROST SYSTEM**



Effective Date: 2017
IMPORTANT INFORMATION
READ BEFORE USE

CONTENTS

RECEIVING & INSPECTING EQUIPMENT.....	1
SERIAL AND MODEL # LOCATION.....	1
WCM-BT - SPECIFICATIONS, FEATURES AND ACCESSORIES.....	2
ELECTRICAL CHARACTERISTICS, CUT-OUT REQUIREMENTS AND REFRIGERATION CHART.....	3
INSTALLATION, OPERATION AND S/S MAINTENANCE.....	4
PARTS LIST.....	5
TROUBLE SHOOTING GUIDE.....	6
ELECTRICAL SCHEMATICS.....	7
LIMITED WARRANTY.....	8
WARRANTY INFORMATION.....	9

RECEIVING AND INSPECTING THE EQUIPMENT

1. VISUALLY INSPECT THE SHIPPING CRATE. DAMAGE SHOULD BE NOTED AND REPORTED TO THE DELIVERING CARRIER.
2. IF DAMAGED, OPEN AND INSPECT CONTENTS WITH CARRIER.
3. IF CRATE IS NOT DAMAGED AND THERE IS CONCEALED DAMAGE TO THE EQUIPMENT, NOTIFY THE CARRIER. NOTIFICATION MUST BE MADE VERBALLY AND IN WRITING.
4. REQUEST AN INSPECTION BY THE SHIPPING COMPANY FOR THE DAMAGED EQUIPMENT WITHIN 10 DAYS FROM RECEIPT OF THE EQUIPMENT
5. FREIGHT CARRIERS CAN SUPPLY THE NECESSARY FORMS ON REQUEST.
6. SAVE ALL CRATING MATERIALS UNTIL INSPECTION HAS BEEN MADE OR WAIVED.

SERIAL NUMBER LOCATION

THE SERIAL AND MODEL# CAN BE FOUND ON THE CONDENSING UNIT ENCLOSURE - SEE OPERATORS SIDE CONTROL PANEL WHEN CALLING ATLAS FOR PARTS AND SERVICE. ALWAYS HAVE THIS INFORMATION AVAILABLE.

SERIAL #: _____

MODEL #: _____

INSTALLATION DATE: _____



Atlas Metal
INDUSTRIES, INC.

A subsidiary of Mercury Aircraft, Inc

1135 N.W. 159th DRIVE, MIAMI, FLORIDA 33169

TEL.: (305) 625-2451 TOLL FREE (800) 762-7565 FAX: (305) 623-0475

Web Page: www.atlasfoodserv.com E-Mail: sales@atlasfoodserv.com

Project: _____

Item No.: _____

Quantity: _____

DROP-IN SERVING EQUIPMENT



WCM-BT-4

COLD PAN

Refrigerated
Air Flow System
Self-Contained with
Defrost System

- WCM-BT-3**
- WCM-BT-4**
- WCM-BT-5**
- WCM-BT-6**

SPECIFICATIONS

TOP: Constructed of 18 gauge, type 304 stainless steel, die stamped with a raised perimeter bead. There shall be a solid vinyl gasket under the beaded edge to form a seal to the counter top, thus preventing seepage or marring of the counter top. Embossed mounting lugs are provided along the inner surface of the top to hold a full set of removable separator channels in place.

LINER: The inner liner shall be 18 gauge, type 304 stainless steel, one piece construction, all welded, ground and polished to a uniform finish. All corners are covered with a minimum 1/4" radius.

INSULATION: The pan is fully insulated with high density polystyrene, 1" thick on all sides, 2" thick on the bottom and enclosed with a 22 gauge galvanized steel outer case.

REFRIGERATION SYSTEM: The compressor housing shall be fabricated from 14 gauge galvanized and bolted to the base of the unit. A fully self-contained condensing unit is provided with a hermetically sealed compressor and a thermostat control. The system is also provided with a forced air evaporator for even temperature throughout the pan that drains into a condensate evaporator pre-wired in the unit. Automatic defrost system is provided. The system is fully charged with CFC free refrigerant and ready to operate.

NOTE: Proper ventilation must be provided in counter.

ELECTRICAL: The unit will be wired for 15 amps., 120 volt, single phase operation with an on/off thermostat switch and pilot light. A 6' long, 3-wire cord and plug (NEMA 5-15P) will be provided.

Specifications subject to change without notice.

STANDARD FEATURES

- Forced air evaporator blower system for maximum efficiency in cooling - more consistent food product temperature
- Automatic Defrost System
- Fully insulated for maximum efficiency and energy savings
- Factory applied gasket - makes installation a snap and seals units to the counter top, thus eliminating seepage
- Accommodates standard 12" X 20" pans with the use of separator channel(s), or fractional size pans with the use of optional adapter bars
- 1-Year Parts & Labor Warranty
- UL Listed

ACCESSORIES

- **5YW** - 5-Year Compressor Warranty
- Stainless Steel adapter bars (pg DI-51-52)
- Stainless Steel adapter plates (pg DI-51-52)
- **CP** - Cover Plate with handles, S/S
- **RS** - Remote on/off switch for counter mounting
- * **220 Volt - 50 Cycle** Compressor

*Please see Operation & Installation Manual for ALL operation and maintenance details.

* Units with these accessories are not currently UL listed.

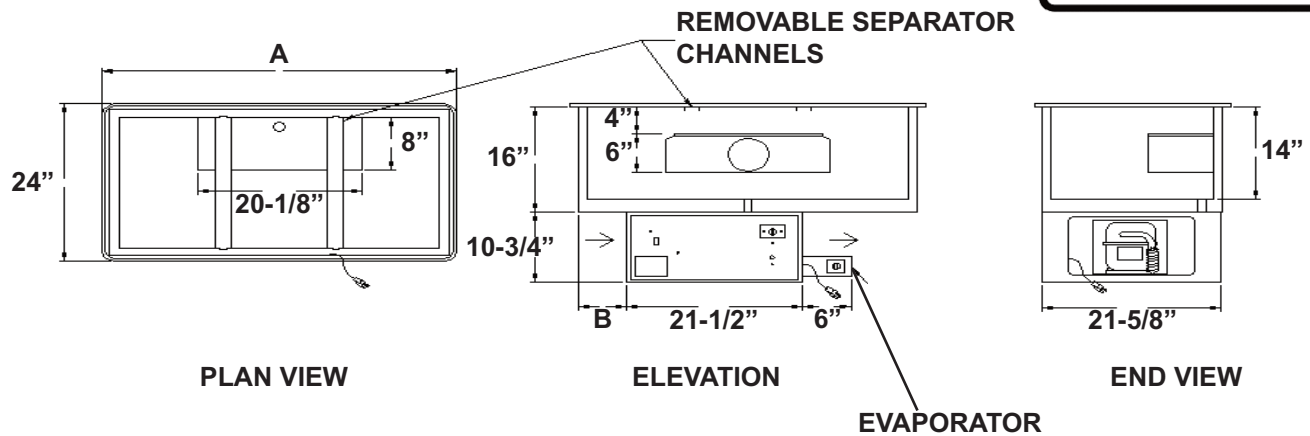

MODEL	"A"	"B"	PAN SIZE	ELECTRICAL CHARACTERISTICS	CUT-OUT REQUIRED	SHIP WT. (LBS.)
WCM-BT-3	43-1/2" (110.4cm)	5-7/8" (14.9cm)	19-7/8" X 39-1/4" X 14" (50.4 X 99.6 X 35.5cm)	6.8 amps. - 120V - 1/4HP	22-1/4" X 41-3/4" (56.5 X 106cm)	228 (103.4kg)
WCM-BT-4	57-1/4" (145.4cm)	4" (10.1cm)	19-7/8" X 53" X 14" (50.4 X 134.6 X 35.5cm)	9.2 amps. - 120V - 1/3HP	22-1/4" X 55-1/2" (56.5 X 140.9cm)	268 (121.5kg)
WCM-BT-5	71" (180.3cm)	6-7/8" (17.4cm)	19-7/8" X 66-3/4" X 14" (50.4 X 169.5 X 35.5cm)	9.2 amps. - 120V - 1/3HP	22-1/4" X 69-1/4" (56.5 X 175.8cm)	311 (141.1kg)
WCM-BT-6	84-3/4" (215.2cm)	5-7/8" (14.9cm)	19-7/8" X 80-1/2" X 14" (50.4 X 204.4 X 35.5cm)	9.2 amps. - 120V - 1/3HP	22-1/4" X 83" (56.5 X 210.8cm)	345 (156.4kg)

REMOTE REFRIGERATION MODEL	LESS COMP. SHIP WT. (LBS.)
WCM-BTX-3	180 (81.6kg)
WCM-BTX-4	222 (100.6kg)
WCM-BTX-5	259 (117.4kg)
WCM-BTX-6	299 (135.6kg)

REFRIGERATION CHART						
MODEL	HP	REF.	OZ.	LOW PSIG.	HIGH PSIG.	BTU M10 90A
WCM-BT-3	1/4	134A	8	10	170	1070
WCM-BT-4	1/3	134A	10	9	190	1285
WCM-BT-5	1/3	134A	10	9	160	1285
WCM-BT-6	1/3	134A	10	9	125	1285

WCM-BTX - REFRIGERATED COLD PAN WITHOUT COMPRESSOR

Units include Refrigerated Cold Pan, Thermostat, Cap Tube & Drier (for hook up in field by others)

COMPRESSORS FOR REMOTE INSTALLATIONS

2029-1 - 1/4 HP for WCM-BTX-3
2029-2 - 1/3 HP for WCM-BTX-4, 5 & 6

REFRIGERATED PAN WITH EVAPORATOR BLOWER & TIMER

WCMBT SERIES

INSTALLATION

Provide the correct counter cut-out opening (see chart below) and drop in. The vinyl gasket assures complete seating. A non-toxic silicone seal may be used between the gasket and counter top (not required).

NOTE: Units are supplied with the nipple PVC and pipe connected to condensing evaporator.

MODEL NUMBER	CUT-OUT SIZE
WCMBT-3	22 1/4 X 41 3/4
WCMBT-4	22 1/4 X 55 1/2
WCMBT-5	22 1/4 X 69 1/4
WCMBT-6	22 1/4 X 83

The unit should be level for draining purposes. When installing unit in a counter, it is recommended that the operator side of the counter be completely open for air circulation. When this is not possible, such as in an island counter, it is recommended that two grill openings are provided approximately 18" x 18" of free air for intake and exhaust at the opposite ends of the counter.

The unit is supplied with a power cord and NEMA plug. Refer to the data plate on the compressor housing for the amperage and voltage information. Use a licensed electrician when installing power source.

OPERATION

The unit should be turned on one hour before serving and turned off after completing the serving period. If the compressor does not start immediately there is a chance the unit is in a defrost mode. A timer is installed to shut down the compressor for defrosting every 8 hour for 15 minutes. For maximum efficiency, empty food pans or covers must be in the openings until unit is ready for product. Do not block discharge or intake openings inside the unit.

The thermostat has an off position and numbers from #1 through #7 (number 7 is the coldest). The unit should be turned off every day after used. Note: **The unit should not operate 24/7.**

MAINTENANCE

NEVER CLEAN PANS WITH A CHLORIDE BASED PRODUCT. CHLORIDES OR IMPROPER CLEANING COULD SCAR, MARK AND/OR CORRODE PANS. **DO NOT** USE STEEL WOOL OR ABRASIVE PRODUCTS. TO CLEAN USE SOAPY WARM WATER, RINSE THOROUGHLY TO REMOVE ALL RESIDUES. **FAILURE TO MEET THESE CONDITIONS WILL VOID WARRANTY.**
CLEAN CONDENSER COIL REGULARLY.

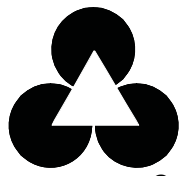

Atlas Metal INDUSTRIES, INC.

Subsidiary of Mercury Aircraft, Inc.

1135 N.W. 159th DR., MIAMI, FL 33169
 PHONE (305) 625-2451, (800) 762-7565, FAX (305) 623-0475, E-mail: sales@atlasfoodserv.com

PARTS LIST REFRIGERATED PAN WITH BLOWER & TIMER WCMBT SERIES

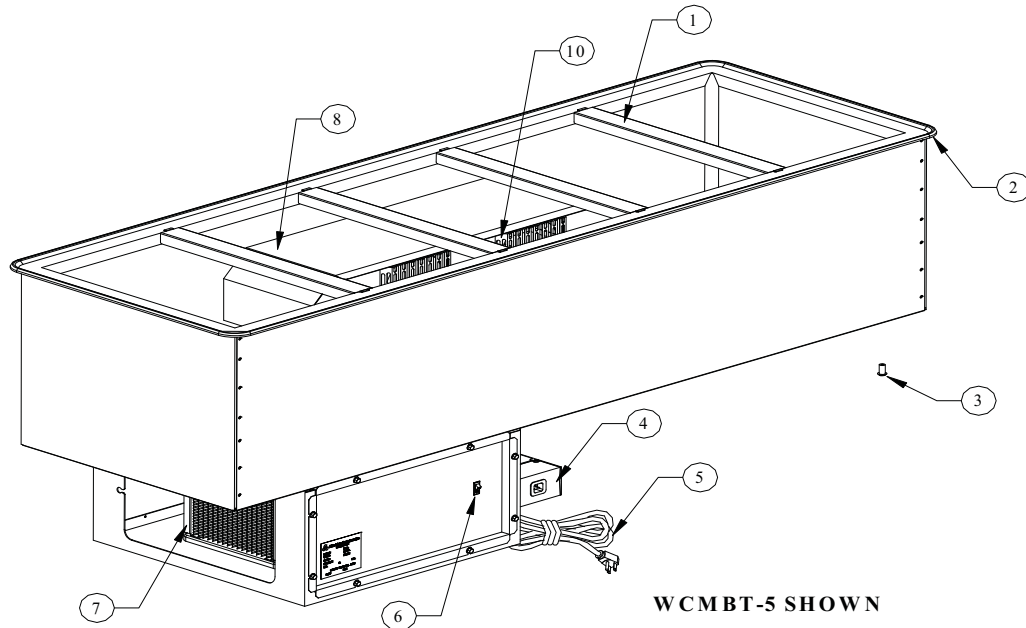

ITEM NUMBER	PART NUMBER	DESCRIPTION
1	S80103-0	Separator Channel
2	7002-0+Model	Vinyl Bead Gasket
3	7020-0	Nylon Spacer
4	2060-1	Condensing Water Evaporator
5	1003-0	Power Cord with Plug
6	1069-1	Switch with Light
7	2029-1	1/4 H.P. Compressor WCMBT-3
	2029-2	1/3 H.P. Compressor WCMBT-4, 5, 6
8	S11855-0	Blower Housing Assembly WCMBT-3
	S81857-0	Blower Housing Assembly WCMBT-4, 5, 6
9	2014-5	Fan Blade (Not Shown)
10	S81443-0	Fan Guard
11	2013-0	Fan Motor (Not Shown)
12	S11857-0	Drain Pan WCMBT-3 (Not Shown)
13	S81862-0	Drain Pan WCMBT-4, 5, 6 (Not Shown)
12	2119-3	Evaporator Coil WCMBT-3 (Not Shown)
	2119-1	Evaporator Coil WCMBT-4, 5, 6 (Not Shown)
13	22-1399	Defrost Thermostat (Not Shown)
14	20-3010	Timer (Not shown)
15	111-1080	Heating Element WCMBT-3 (Not Shown)
	111-1071	Heating Element WCMBT-4, 5, 6 (Not Shown)
16	2026-0	0.042 Cap Tube (Not Shown)
17	1150	Harness (Not Shown)
18	2025-0	Drier (Not Shown)
19	2044-0	Thermostat (Not Shown)

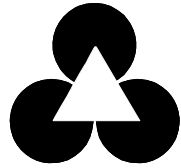

Atlas Metal INDUSTRIES, INC.

Subsidiary of Mercury Aircraft, Inc.

1135 N.W. 159th DR., MIAMI, FL 33169

PHONE (305) 625-2451, (800) 762-7565, FAX (305) 623-0475, E-mail: sales@atlasfoodserv.com

Refrigerated Drop-In Trouble Shooting Guide	
Symptom	Probable Cause
Unit will not run	Unit not plugged in. No power at receptacle. Thermostat and or switch not in the on position. Unit may be in a defrost cycle (if supplied) wait approximately 20 min. Call factory for service at 1-800-762-7565
Condenser runs but short cycles	Condenser coil dirty Inadequate ventilation. Call factory for service at 1-800-762-7565
Condenser runs constantly.	Condenser coil dirty. Inadequate ventilation. Unit installed in a hot location Call factory for service at 1-800-762-7565 NOTE: WF series runs constantly.
Food product not cold enough.	Food product must be chilled to 33-35 deg. when placed in unit. Air movement over food product. Food product not being stirred or rotated. Call factory for service at 1-800-762-7565

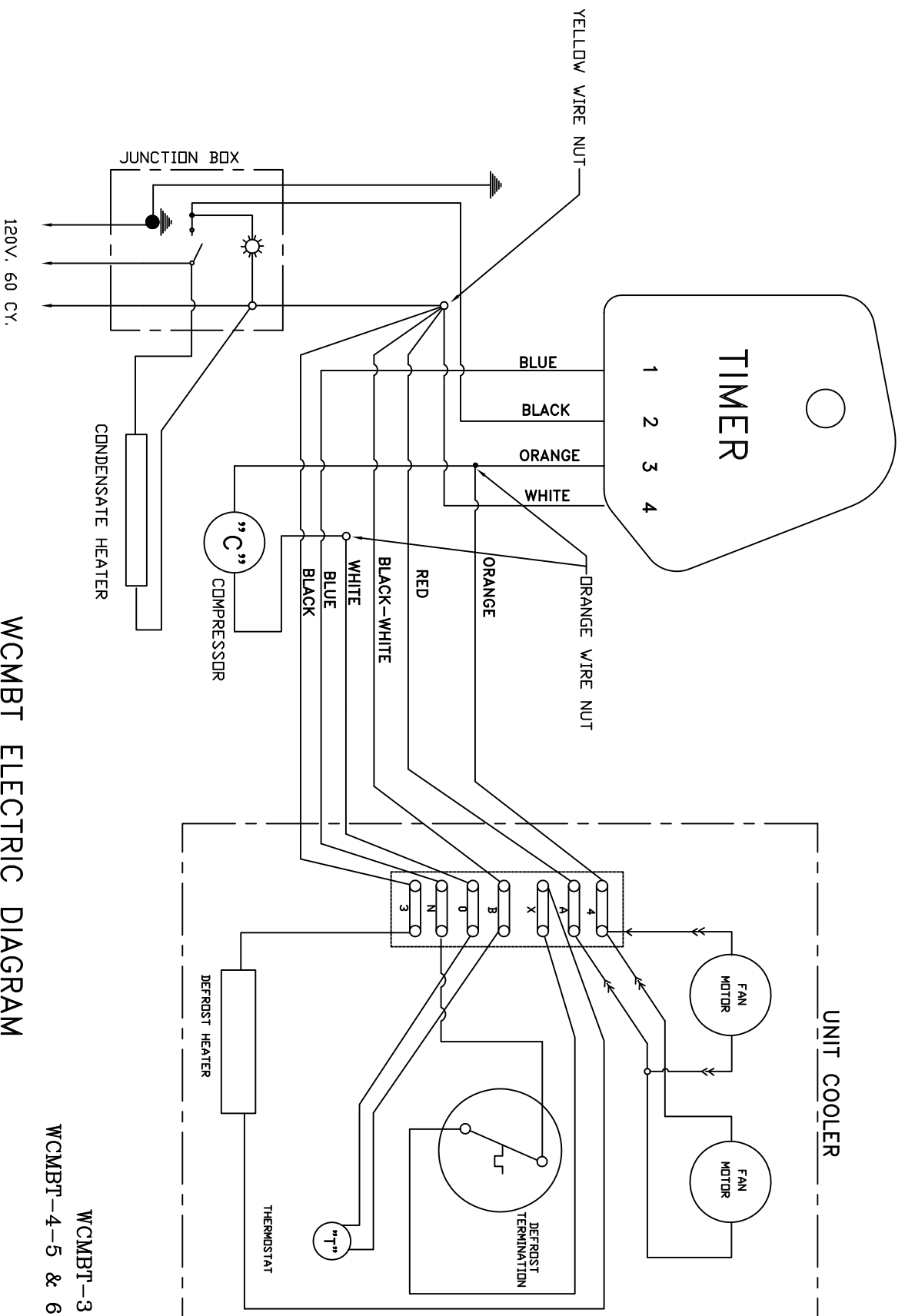

WCMBT ELECTRIC DIAGRAM

WCMBT-3 1/4 H.P
 WCMBT-4-5 & 6 1/3 H.P

These plans are the exclusive property of Atlas Metal Industries Inc. Any unauthorized use without written consent of Atlas Metal Industries Inc., is strictly prohibited.

ATLAS METAL INDUSTRIES, INC.
 1135 NW 159TH DRIVE
 MIAMI, FLORIDA 33169

REVISION CHANGES		DATE:	CUSTOMER:
DATE:	DESCRIPTION:	9-17-08	WCMBT ELECTRICAL SCHEMATIC
9-17-08	ON CAD	MHA	REFERENCE:
		MHA	WCMBT 3-4-5-6
		NEILSONS	DRAWING No.
			WCMBT ELECT.SCHEMATIC
			SCALE 3/4"=1'
			SHEET NO. 1 of 1

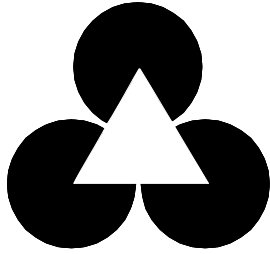

Atlas Metal
INDUSTRIES, INC.

LIMITED WARRANTY

Atlas Metal Industries, Inc. warrants to the Purchaser of this product that the same shall be free from defects in the workmanship and material for a period of one year from the date of original installation of the equipment, but not to exceed eighteen (18) months after date of shipment from factory. During this period of time Atlas Metal Industries, Inc. will replace all defective parts and will pay for authorized replacement labor. Replacement and installation of such parts and labor shall be provided only upon prior written authority of Atlas Metal Industries, Inc.

The Refrigeration warranty is for a twenty (20) month time period and includes supplying the compressor at a no charge basis provided the damage to the compressor was not caused by the customer or end user. Authorized replacement labor will be paid for a period of one year from date of installation. Freight costs for defective unit to and from Atlas Metal Industries, Inc. are not included, and all defective parts must be returned to the factory freight prepaid for evaluation. **ALL WARRANTY LABOR MUST BE AUTHORIZED BY ATLAS METAL INDUSTRIES, INC. PRIOR TO THE ACTUAL WORK BEING DONE.** This warranty does not apply to any equipment or any part thereof, which has been subjected to shipping damage, improper voltage, alteration, abuse or misuses, and does not cover loss of food, other products, or damage to property due to mechanical or electrical malfunction.

THERE ARE NO WARRANTIES WHICH EXTEND BEYOND THE DESCRIPTION OF THE FACE HEREOF. SELLER DISCLAIMS ANY IMPLIED WARRANTY OF MERCHANTABILITY OF THE GOODS OR THE FITNESS OF THE GOODS FOR ANY PURPOSE AND BUYER AGREES THAT THE GOODS ARE SOLD "AS IS."

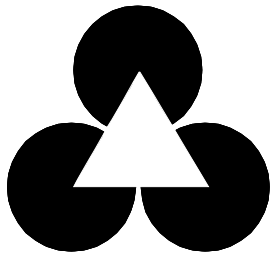

Atlas Metal
INDUSTRIES, INC.

WARRANTY INFORMATION

In order to have your invoice approved for payment by the factory, please note the following:

An authorization number must be obtained from the factory prior to performing any warranty service.

Atlas Metal will not approve excessive labor due to poor access to the unit being serviced. If design does not allow reasonable access, contact the factory.

All travel time that exceeds 100 miles round trip must be authorized by the factory.

**Thank You:
Warranty service Dept.**