

1135 N.W. 159th DR., MIAMI, FL 33169
PHONE (305) 625-2451, (800) 762-7565, FAX (305) 623-0475, E-mail: sales@atlasfoodserv.com

PARTS LIST ICE CREAM FREEZERS WDF & WDFL SERIES

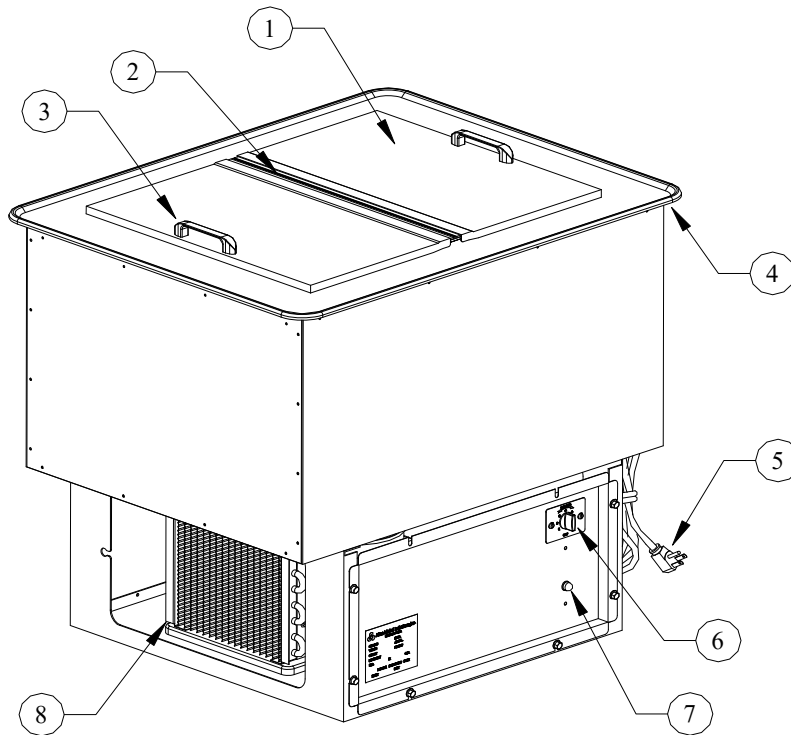

**WDF-2
SHOWN**

ITEM NUMBER	PART NUMBER	DESCRIPTION
1	S11054 + Model #	WDF Lid Assembly
	S33155-0	WDFL Lid Assembly
2	S11014-0	WDF Hinge
	S81809-0	WDFL Hinge
3	6043-0	Lid Handles
4	7002-0+Model #	Vinyl Bead Gasket
5	1003-0	Power Cord with Plug
6	2043-0	Thermostat
7	1099-0	Pilot Light
8	2029-0	1/5 H.P. Compressor WDFL
	2029-1	1/4 H.P. Compressor WDF-2 & 3
9	4043-1	Handle Screws (Not Shown)
10	7003-0+Model #	Throat Gasket (Not Shown)
11	2027-0	0.031 Cap Tube for 1/5 H.P. Comp. WDFL only (Not Shown)
12	2026-0	0.042 Cap Tube for 1/4, H.P. Comp. (Not Shown)
13	2025-0	Drier (Not Shown)
14	7030-0	WDFL Plastic Underlid (Not shown)
15	7031-0	WDF-2-3 Plastic Underlid (Not Shown)
16	7032-0	WDF-3 Center Underlid (Not Shown)
16	600008	Thermostat Knob

ICE CREAM FREEZERS

WDF & WDFL SERIES

INSTALLATION

Provide the correct counter cut-out opening (see chart below) and drop in. The vinyl gasket assures complete seating. A non-toxic silicone seal may be used between the gasket and counter top (not required).

MODEL NUMBER	CUT-OUT SIZE
WDF-2	22 1/4 X 28
WDF-3	22 1/4 X 41 3/4
WDF-L	15 X 26

When installing unit in a counter, it is recommended that the operator side of the counter be completely open for air circulation. When this is not possible, such as in an island counter, it is recommended that two grill openings are provided approximately 18" x 18" of free air for intake and exhaust at the opposite ends of the counter.

The unit is supplied with a power cord and NEMA plug. Refer to the data plate on the compressor housing for the amperage and voltage information. Use a licensed electrician when installing power source.

OPERATION

The unit is ready to operate as soon as it is plugged in. The thermostat has an off position and numbers from #1 through #7 (number 7 is the coldest). The unit should be turned off every day after used and turned on one hour before serving.

MAINTENANCE

NEVER CLEAN PANS WITH A CHLORIDE BASED PRODUCT. CHLORIDES OR IMPROPER CLEANING COULD SCAR, MARK AND/OR CORRODE PANS. **DO NOT** USE STEEL WOOL OR ABRASIVE PRODUCTS. TO CLEAN USE SOAPY WARM WATER, RINSE THOROUGHLY TO REMOVE ALL RESIDUES. **FAILURE TO MEET THESE CONDITIONS WILL VOID WARRANTY.**

CLEAN CONDENSER COIL REGULARLY.