



ATLAS METAL

1135 N.W. 159th DRIVE, MIAMI, FLORIDA 33169

TEL 305.625.2451

TOLL FREE 800.762.7565

FAX 305.623.0475

WIH 17-67 SERIES

Service and Installation Manual

Please read this manual completely before attempting to install or operate this equipment!
Notify carrier of damage! Inspect all components immediately. See page 1.



WIH-37



Effective Date: 2023
IMPORTANT INFORMATION
READ BEFORE USE

CONTENTS

RECEIVING & INSPECTING EQUIPMENT.....	1
SERIAL AND MODEL NUMBER LOCATION.....	1
SPECIFICATIONS, FEATURES AND ACCESSORIES.....	2
ELECTRICAL CHARACTERISTICS AND CUT-OUT REQUIREMENTS.....	3
REMOTE CONTROL INSTALLATION.....	4
PARTS LIST.....	5
INSTALLATION, OPERATION AND S/S MAINTENANCE.....	6-7
AUTOMATIC WATER FILL INSTALLATION, OPERATION & PARTS DIAGRAM.....	8-11
TROUBLE SHOOTING GUIDE.....	12
ELECTRICAL SCHEMATICS 120V.....	13
ELECTRICAL SCHEMATICS 208V - 240V.....	14
LIMITED WARRANTY.....	15
WARRANTY INFORMATION.....	16

RECEIVING AND INSPECTING THE EQUIPMENT

1. VISUALLY INSPECT THE SHIPPING CRATE. DAMAGE SHOULD BE NOTED AND REPORTED TO THE DELIVERING CARRIER.
2. IF DAMAGED, OPEN AND INSPECT CONTENTS WITH CARRIER.
3. IF CRATE IS NOT DAMAGED AND THERE IS CONCEALED DAMAGE TO THE EQUIPMENT, NOTIFY THE CARRIER. NOTIFICATION MUST BE MADE VERBALLY AND IN WRITING.
4. REQUEST AN INSPECTION BY THE SHIPPING COMPANY FOR THE DAMAGED EQUIPMENT WITHIN 10 DAYS FROM RECEIPT OF THE EQUIPMENT
5. FREIGHT CARRIERS CAN SUPPLY THE NECESSARY FORMS ON REQUEST.
6. SAVE ALL CRATING MATERIALS UNTIL INSPECTION HAS BEEN MADE OR WAIVED.

SERIAL NUMBER LOCATION

THE SERIAL AND MODEL# CAN BE FOUND ON THE OPERATORS CONTROL PANEL. WHEN CALLING ATLAS FOR PARTS AND SERVICE ALWAYS HAVE THIS INFORMATION AVAILABLE.

SERIAL #: _____

MODEL #: _____

INSTALLATION DATE: _____



ATLAS METAL

1135 N.W. 159th DRIVE, MIAMI, FLORIDA 33169

TEL 305.625.2451

TOLL FREE 800.762.7565

FAX 305.623.0475

WWW.ATLASFOODSERV.COM

SALES@ATLASFOODSERV.COM

Project: _____

Item No.: _____

Quantity: _____

DROP-IN SERVING EQUIPMENT



WIH-37

HOT PAN

Electrically Heated
Individual Controls
Large Capacity 12" X 27"
Pan Size Opening

- WIH-17
- WIH-27
- WIH-37
- WIH-47
- WIH-57
- WIH-67

SPECIFICATIONS

TOP: Constructed of 18 gauge, type 304 stainless steel, die stamped with a raised perimeter bead. There shall be a solid vinyl gasket under the beaded edge to form a seal to the counter top, thus preventing seepage or marring of the counter top.

HOT FOOD WELLS: Individual hot food wells shall be 18 gauge, type 304 stainless steel, one piece construction, all welded, ground and polished to a uniform finish. All corners are covered with a minimum 1/4" radius. Each well is provided with an 850 watt heating element (1000 watt on the WIH-17).

INSULATION: The pan is fully insulated with high density fiberglass, 1" thick on all sides, 2" thick on the bottom and enclosed with a 22 gauge galvanized steel outer case.

ELECTRICAL: The unit is provided with an individual thermostat control with a pilot light for each well. All heating elements and controls are pre-wired, and a 6' long, 3-wire cord and plug is provided, extending from the control box located under the unit, on operator's left. Bottom of outer case can be removed for access to electrical components.

Specifications subject to change without notice.

STANDARD FEATURES

- Fully insulated to retain heat - protects fixtures and saves energy
- Individual thermostat controls - the operator can control the temperature of each well separately
- Factory applied gasket - makes installation a snap and seals units to the counter, thus eliminating seepage
- Accommodates standard 12"x20" pans, or fractional size pans with the use of adapter bars
- Wet or Dry Operation
- 1-Year Parts & Labor Warranty
- UL Listed

ACCESSORIES

- Stainless steel adapter bars (pg DI-51-52)
- Stainless steel adapter plates (pg DI-51-52)
- **D** - Individual Drain and Valve for each well (3/4" dia. drain)
- **DM** - Individual Drain for each well with manifold to single valve
- **DMV** - Individual Drain with valve for each well with manifold to single valve
- **DME** - Individual drain for each well with manifold to single valve w/ rear extension
- **RDVE** - Rear Extension for **D**, **DM**, **DMV** & **DME** (1) required
- **RT** - Remote Thermostats for counter installation, 36" long
- **RTL** - Remote Thermostats for counter installation, 72" long
- **MS** - Master on/off switch
- **AF** - Automatic water fill (NOTE: **DM** required for water fill)

*Please see Operation & Installation Manual for ALL operation and maintenance details.



CONFORMS TO
NSF/ANSI STD 4
NSF/ANSI STD 2

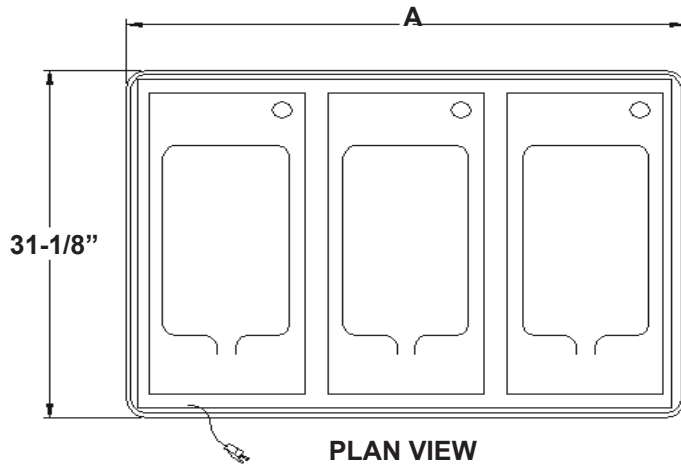

SHOWN WITH OPTIONAL DME -
DRAIN AND MANIFOLD WITH
REAR EXTENSION

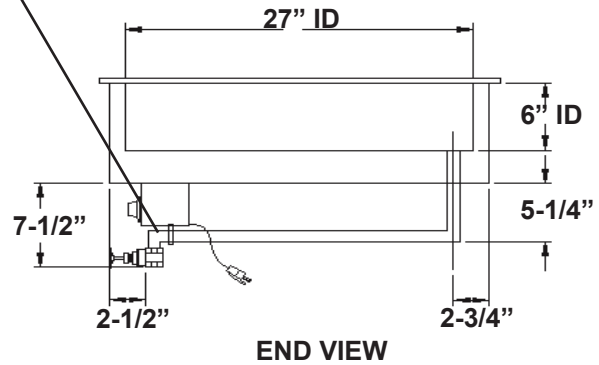
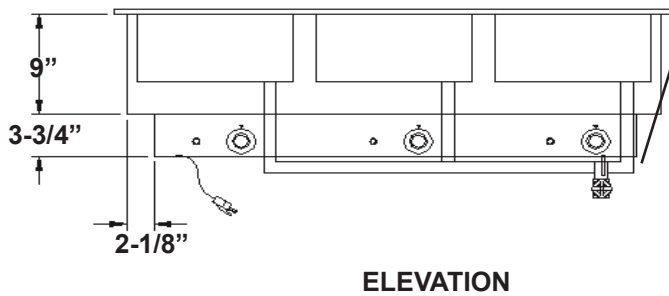

Electrical Characteristics

MODEL	WATTAGE	VOLTAGE/KW/AMPS	NEMA # PLUG
WIH-17	1000WATT	120V - 1.0KW - 8.3	5-15P
		208V - 1.0KW - 4.8	6-15P
		240V - 1.0KW - 4.2	6-15P
WIH-27	850WATT	120V - 1.7KW - 14.2	5-20P
		208V - 1.7KW - 8.2	6-15P
		240V - 1.7KW - 7.1	6-15P
	1000WATT	120V - 2.0KW - 16.7	5-30P
		208V - 2.0KW - 9.6	6-15P
		240V - 2.0KW - 8.3	6-15P
WIH-37	850WATT	120V - 2.55KW - 21.3	5-30P
		208V - 2.55KW - 12.3	L6-20P
		240V - 2.55KW - 10.6	6-15P
	1000WATT	120V - 3.0KW - 25.0	5-50P
		208V - 3.0KW - 14.4	L6-20P
		240V - 3.0KW - 12.5	L6-20P
WIH-47	850WATT	208V - 3.4KW - 16.4	L6-30P
		240V - 3.4KW - 14.2	L6-20P
			1000WATT
240V - 4.0KW - 16.7	L6-30P		
WIH-57	850WATT		
		240V - 4.25KW - 17.7	L6-30P
			1000WATT
240V - 5.0KW - 20.8	L6-30P		
WIH-67	850WATT		
		240V - 5.1KW - 21.3	L6-30P
			1000WATT
240V - 6.0KW - 25.0	6-50P		

MODEL	"A"	COUNTER CUT-OUT (REQUIRED) W X L	CONTROL PANEL CUT-OUT (IF REQUIRED)	SHIP WT. (LBS.)
WIH-17	16" (40.6cm)	29-3/8" X 14-1/4" (74.5 X 36.8cm)	4-1/2" X 6-1/4" (11.4 X 15.8cm)	67 (30.3kg)
WIH-27	29-3/4" (75.5cm)	29-3/8" X 28" (74.5 X 71.1cm)	4-1/2" X 12-1/4" (11.4 X 31.1cm)	153 (69.3kg)
WIH-37	43-1/2" (110.4cm)	29-3/8" X 41-3/4" (74.5 X 111.1cm)	4-1/2" X 26" (11.4 X 66cm)	195 (88.4kg)
WIH-47	57-1/4" (145.4cm)	29-3/8" X 55-1/2" (74.5 X 140.9cm)	4-1/2" X 39-3/4" (11.4 X 100.9cm)	237 (107.5kg)
WIH-57	71" (180.3cm)	29-3/8" X 69-1/4" (74.5 X 175.8cm)	4-1/2" X 53-1/2" (11.4 X 135.8cm)	268 (121.5kg)
WIH-67	84-3/4" (213.3cm)	29-3/8" X 83" (74.5 X 210.8cm)	4-1/2" X 67-1/4" (11.4 X 170.8cm)	351 (159.2kg)

Note: Numeral following the model letters denotes the 12X20 pan capacity



ATLAS METAL

Subsidiary of Mercury Aircraft, Inc.

1135 N.W. 159th DR., MIAMI, FL 33169

PHONE (305) 625-2451, (800) 762-7565, FAX (305) 623-0475, E-mail: sales@atlasfoodserv.com

WIHD 17-67 LARGE SERIES INSTALLATION

WIH-REMOTE INSTALLATION

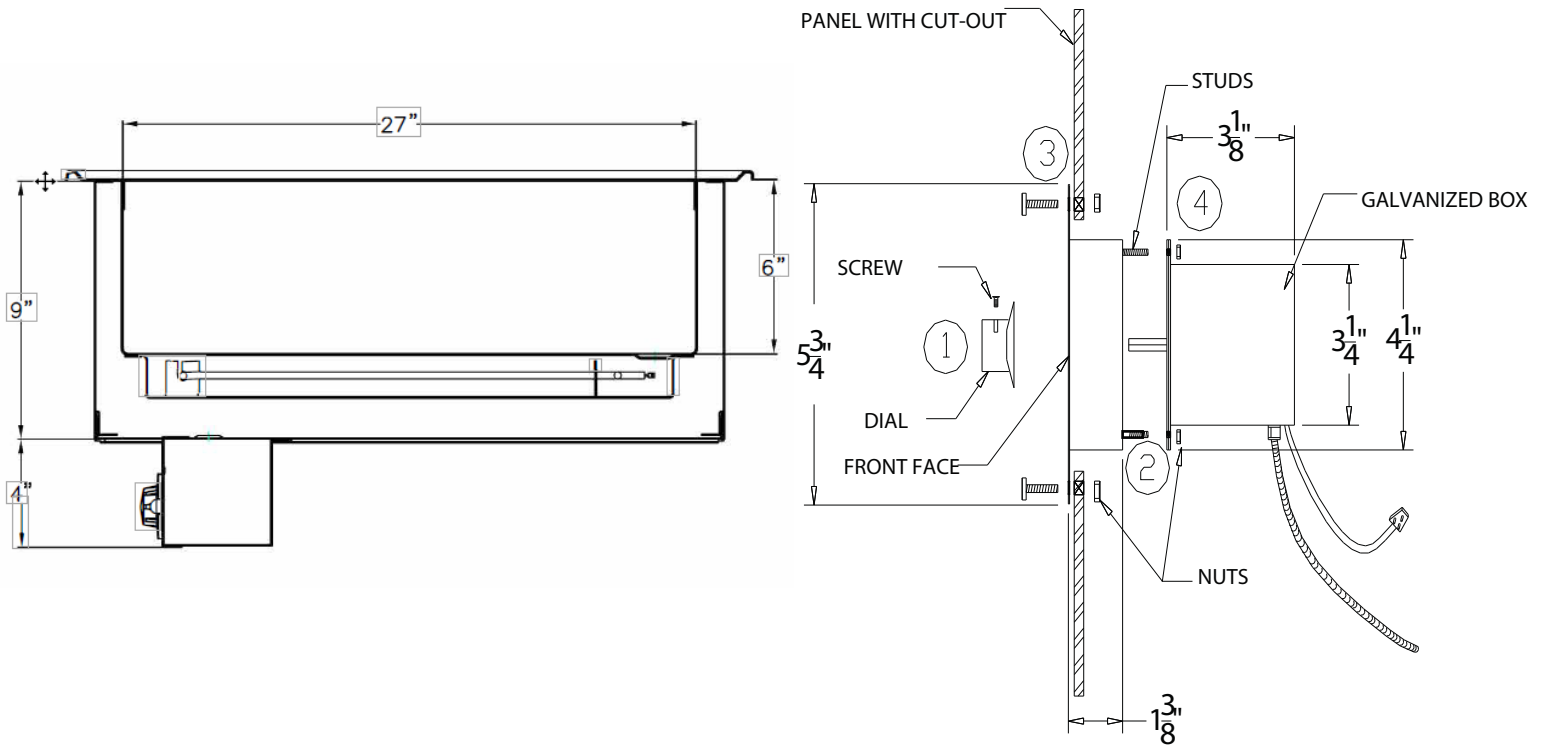

INSTALLATION OF THE REMOTE CONTROL HOT UNITS

Provide the correct Cut-Out opening for the remote control panel (see chart below).
Remove control box from the bottom of the unit.

- 1) Remove black control dial from front of control panel by loosening screws.
- 2) Remove 6/32 fiber nuts from the back of the control box.
- 3) Mount the S/S front plate to the Cut-Out in apron.
- 4) Attach the galvanized box to the S/S front plate.

The unit is ready to be connected to the electrical receptacle. Refer to the data plate on the control panel for the amperage and voltage information. Use a licensed electrician when installing power source.

MODEL	CUT-OUT SIZE
1	4 1/2 x 6 1/4
2	4 1/2 x 12 1/4
3	4 1/2 x 26
4	4 1/2 x 39 3/4
5	4 1/2 x 53 1/2
6	4 1/2 x 67 1/4

CAUTION: HANDLE CONTROL PANEL & CONDUIT CAREFULLY, THERMOSTAT CAPILLARY TUBE IS VERY FRAGILE, IF BROKEN, HEATING SYSTEM WILL NOT OPERATE.

FAILURE TO MEET THESE CONDITIONS WILL VOID WARRANTY.



Subsidiary of Mercury Aircraft, Inc.

1135 N.W. 159th DR., MIAMI, FL 33169
 PHONE (305) 625-2451, (800) 762-7565, FAX (305) 623-0475, E-mail: sales@atlasfoodserv.com

PARTS LIST ELECTRICAL HEATED UNITS
W/AUTOMATIC WATER FILL
WH/ WIHD&M/ WIHLD&M- /WIHD&M- 17-67 SERIES

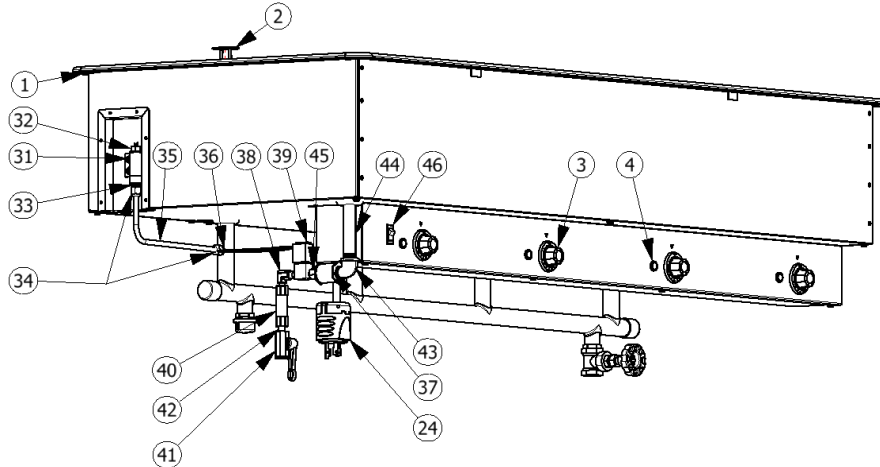

ITEM NUMBER	PART NUMBER	DESCRIPTION
1	7002-0+Model #	Vinyl Bead Gasket
2	86-3202	Perforated Snap in Drain
3	1097-2	Dial Knob (used on STD, AMC, RT, RTL)
4	1100	Pilot Light
5	3007-3	3/4" Brass Nipple 7" long
6	3016-11	Brass Gate Valve
7	1089-5	P-136 Terminal (#22 & 18 wire)
8	1089-2	P-151 Terminal (#10 & 12 wire)
9	1089-4	P-144 Terminal (#14 & 16 wire)
10	1098	S Screw Thermostat Mounting
11	1096-60	Remote Thermostat with 48" Bulb
12	1096-96	Remote Thermostat with 72" Bulb
13	1012-100	12" Nickel Wire
14	1014-100	14" Nickel Wire
15	1096-36	Thermostat
16	S81113-2	Element Holder
17	S81114-000	S/S Element Holder
18	1053-HT	120V-850W Element
19	1054-HT	208V-850W Element
20	1055-HT	240V-850W Element
21	1056-HT	120V-1000W Element
22	1057-HT	240V-1000W Element
23	1058-HT	208V-1000W Element
24	1002	Power Cord 14/3
	1004	Power Cord 12/3
	1004-4	Power Cord 10/3

ITEM NUMBER	PART NUMBER	DESCRIPTION
25	12-228	Plug 20Amp 240V
26	1022	Plug 30Amp 240V
27	12-256	Plug 30Amp 120V
28	1012-101	#12 Green Wire (Ground)
29	1014-101	#14 Green Wire (Ground)
30	1001-1	50 Amp Cord & Plug
31	48-22	S/S 10 x 1/2 Screws
32	S84553	Reservoir Assembly
33	51-25	1/4" x 3/8" NPT Male Conn.
34	2050	Brass Flare Nut
35	2031	1/4" Copper Tubing
36	21-23	1/4" x 1/4" Brass Union
37	600022-1	Dual check vacuum breaker #98d NPTM 1/4" (BACK FLOW PREVENTION)
38	30-46	90° Street Elbow
39	1800-3904	Solenoid Valve 120V
	1800-3903	Solenoid Valve 240V
40	600002	Brass In Line Strainer
41	1800-35	Ball In Valve
42	1800-39	Close Nipple
43	87-69	90° 1/2" to 1/4" Reducing Elbow Brass
44	87-70	1/2 dia. Brass Pipe Threaded Both Ends
45	87-68	1/8" Male to 1/4" female reducer
46	1069-1	Switch

ELECTRICAL HEATED UNITS

WH/ WIHD&M/ WIHLD&M/ WIHDM 17-67 SERIES

INSTALLATION

Provide the correct counter cut-out opening (see chart below) and drop in. The vinyl gasket assures complete seating. A non-toxic silicone seal may be used between the gasket and countertop (not required). The unit is supplied with a power cord and NEMA plug. Refer to the data plate on the control panel for the amperage and voltage information. Use a licensed electrician when installing power source.

MODEL NUMBER	CUT-OUT SIZE
WIHD-1 * (Control Box on 14 1/4 side)	22 1/4 X 14 1/4
WH-2/ WIH-D&M-2	22 1/4 X 28
WH-3/ WIH-D&M-3	22 1/4 X 41 3/4
WH-4/ WIH-D&M-4	22 1/4 X 55 1/2
WH-5/ WIH-D&M-5	22 1/4 X 69 1/4
WH-6/ WIH-D&M-6	22 1/4 X 83
WIHL-D&M-2	14 1/4 X 44 1/4
WIHL-D&M-3	14 1/4 X 66
WIHL-D&M-4	14 1/4 X 87 3/4
WIHD-17/ WIH-D-17	29 3/8 X 14 1/4
WIH-D&M-27	29 3/8 X 28
WIH-D&M-37	29 3/8 X 41 1/4
WIH-D&M-47	29 3/8 X 55 1/2
WIH-D&M-57	29 3/8 X 69 1/4
WIH-D&M-67	29 3/8 X 83

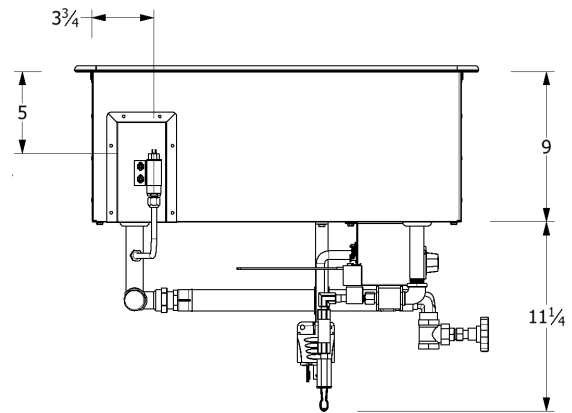

SIDE SECTIONAL VIEW

OPERATION

The unit can be used wet or dry, however the use of water is recommended. **Note: The Auto Fill Assembly is pre-set at the factory: 1/4" for WIH units and 1/2" for WH- units.** The thermostat dial has an off position and numbers from 1 to 10 (Number 10 is the highest setting)

WH & WIH WET (WITH WATER) OPERATION

- 1) Close individual drain valves.
- 2) Fill the unit with water (preferably hot water) until the level assigned.
- 3) Cover the well(s) with a lid, turn the T-Stat to position #10 and wait 45 minutes for the unit to heat up, then you can lower the T-Stat to your desired temp.
- 4) Insert pans with food. Be cautious, unit is hot.
- 5) Check the water level every 2 hours.

WH & WIH DRY (WITHOUT WATER) OPERATION

- 3) Cover the well(s) with a lid, turn the T-Stat to position #10 and wait 15 minutes for the unit to heat up, then you can lower the T-Stat to your desired temp.
- 2) Insert pans with food. Be cautious, unit is hot.

MAINTENANCE

NEVER CLEAN PANS WITH A CHLORIDE BASED PRODUCT. CHLORIDES OR IMPROPER CLEANING COULD SCAR, MARK AND/OR CORRODE PANS. **DO NOT** USE STEEL WOOL OR ABRASIVE PRODUCTS. TO CLEAN USE SOAPY WARM WATER, RINSE THOROUGHLY TO REMOVE ALL RESIDUES. **FAILURE TO MEET THESE CONDITIONS WILL VOID WARRANTY.**

AUTOMATIC WATER FILL UNITS

WIH, WH AND WCMHP/RMHP SERIES

INSTALLATION

A factory supplied in-line water strainer is installed. When installing the water supply to the unit, use flexible or removable tubing to the water inlet, so that access to clean the strainer is available. The supply lines must be purged to remove particles from damaging the solenoid valve operation. Do not remove or relocate the water reservoir. Failure to do so may result in warranty denial. It is recommended the customer supply a primary water filtering system for protection.

*Note-Atlas Metal Ind. Inc. is not responsible for routine maintenance of the strainer or customer supplied water filter system.

*Atlas Metal Industries Inc. recommends that all units installed to a water source use our Autofill or any backflow protection of your choice. Please refer to your local code.

Any attempt to change or modify the Auto Fill system will void the warranty.

OPERATION

HEATING CYCLE

1. Turn master switch to "OFF" position.
2. Close drain valve.
3. Turn master switch to "ON" position.
4. Turn on Auto Fill.
5. Fill unit, preferably with "HOT" water until heating element is completely submerged (water must be level.)

WARNING: HEATING ELEMENT WILL BE DAMAGED IF NOT SUBMERGED AT ALL TIMES DURING HEATING CYCLE!

6. Turn selector switch to "HOT".
7. Select desired setting on heating thermostat dial (1-Warm, 10-Hot).
8. Cover unit with serving pans. Unit will be ready for serving in approximately 30 minutes.

OPERATOR MUST CHECK PERIODICALLY THAT HEATING ELEMENT IS SUBMERGED.

HEATING TO COOLING

1. Turn master switch to "OFF" position
2. Remove serving pans.
3. Drain hot water completely.
4. Turn selector switch to "COLD".
5. Turn master switch to "ON".

CAUTION: Unit is equipped with a safety device. The compressor will not turn until stainless liner temperature is at 120 degrees or below.

6. For WCM-HP Select desire cooling thermostat setting (1-Cool, 7-Coldest). For RM-HP, no setup necessary; Unit ships with factory temperature controls complete.
7. Cover unit with serving pans. Unit will cool down and be ready for serving in approximately 30 minutes

***Unit is not intended to operate 24/7.**

COOL TO HEAT

Follow same steps shown for heat cycle

AUTOMATIC WATER FILL UNITS

***Note** - Factory water depth settings for A/F units are 3/8" from the bottom of the liner and for WCM-HP and RM-HP, water depth should be 4" from the bottom of the liner.

DO NOT manually add water to Auto-fill units above water level mark, damage and leakage to the Automatic sensor could result. As the water evaporates the pans will fill automatically.

If the orange warning light turns on, please turn off the unit and check that the autofill is working properly.

It is recommended that the Auto Fill be in the off position when not in use.

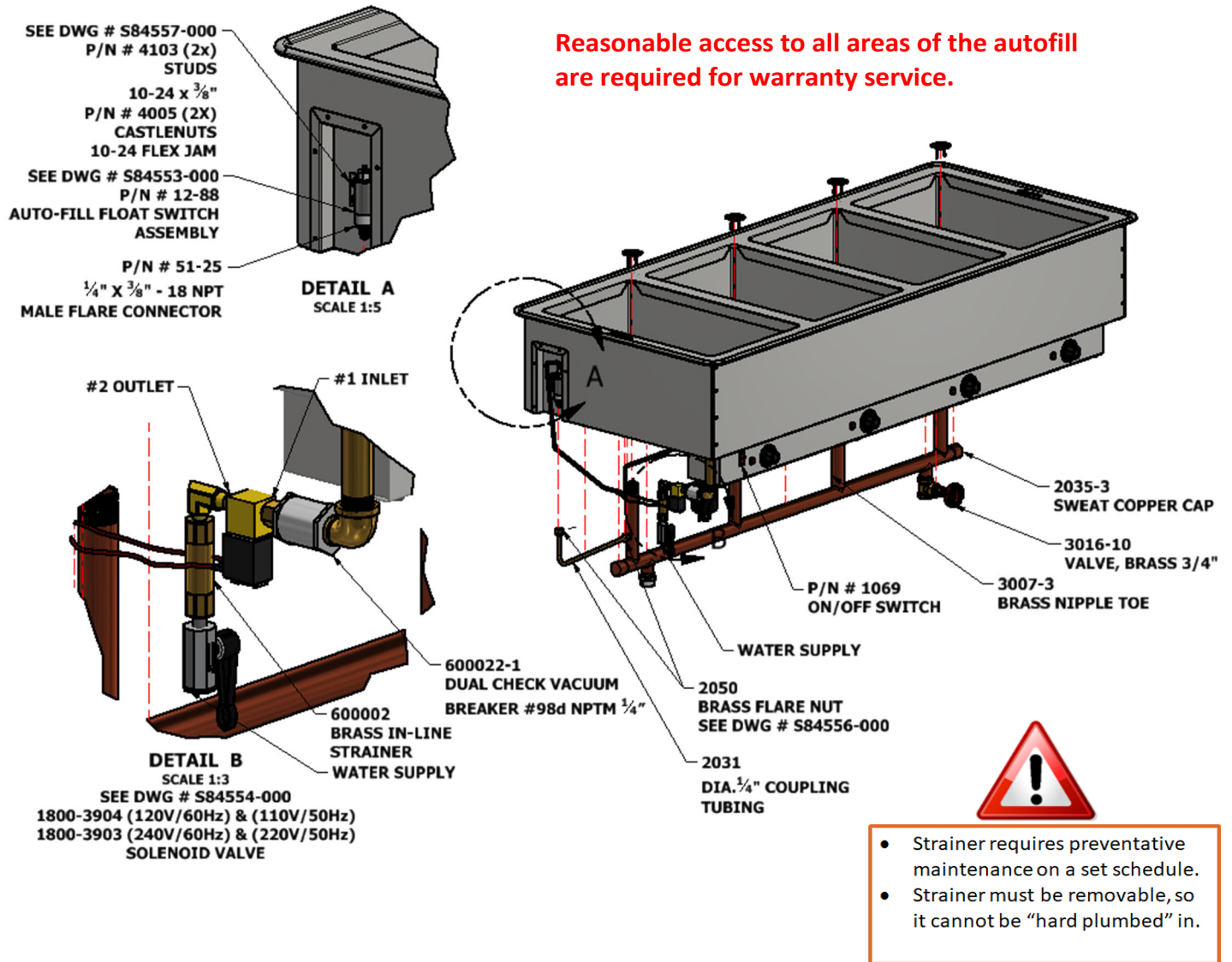

Note - Atlas Metal highly recommend the installation of a water filtration kit or "whole house" water filtration system to ensure warranty coverage.

Atlas Metal Industries, Inc. is not responsible for routine maintenance of the strainer, or the customer supplied water filter system.



ATLAS METAL

1135 N.W. 159th DRIVE, MIAMI, FLORIDA 33169

TEL 305.623.0451 TOLL FREE 800.762.7565 WWW.ATLASFOODSERV.COM FAX 305.623.047



The Automatic Water Fill contains sensitive components. Atlas Metal recommends the following to safeguard your water fill.

Components:

- Float Switch
- Solenoid Valve
- Back-Flow Prevention Valve (required by NSF)

Atlas Metal requires the installation of a water filtration kit or “whole house” water filtration system to ensure warranty coverage. Maintenance issues resulting in hindering the proper function of the equipment will be the responsibility of the end user.

Without such system, the unit is susceptible to hard water contaminants. Contaminants such as calcium and magnesium, and/or other mineral particles can build up in the Automatic Water Fill. These contaminants can build up in the Float Switch and Back-Flow Prevention Valve and may prevent them from closing completely during operation. This may lead to a water leak.

If such scenario occurs, the components must be replaced for peak operation.



FAILURE TO FOLLOW THE FOLLOWING INSTRUCTIONS MAY VOID YOUR WARRANTY

1. **When installing the water supply, NEVER hard pipe installs to the water inlet.** A factory supplied in-line water strainer is installed after the water-inlet valve. Use a flexible or removable tubing to the water inlet that is easily accessible and removable to maintain the strainer.
2. The **supply lines should be purged often** to remove particles from damaging the solenoid valve operation.
3. The **strainer should be cleaned often** to avoid sediment build up that can prohibit AutoFill operations.
4. **Do NOT manipulate the AutoFill.** The AutoFill is arranged, installed, and preset from the factory to meet optimal operations and conditions. Manipulating the AutoFill can cause the unit to fail, leak, and void your warranty.

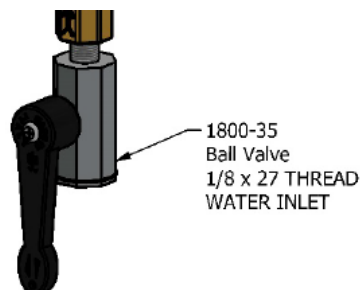

Note - Atlas Metal Industries, Inc. is not responsible for routine maintenance of the strainer or the customer supplied water filter system.



ATLAS METAL

1135 N.W. 159th DRIVE, MIAMI, FLORIDA 33169

TEL 305.623.2451 TOLL FREE 800.762.7565 WWW.ATLASMETAL.COM FAX 305.623.0475

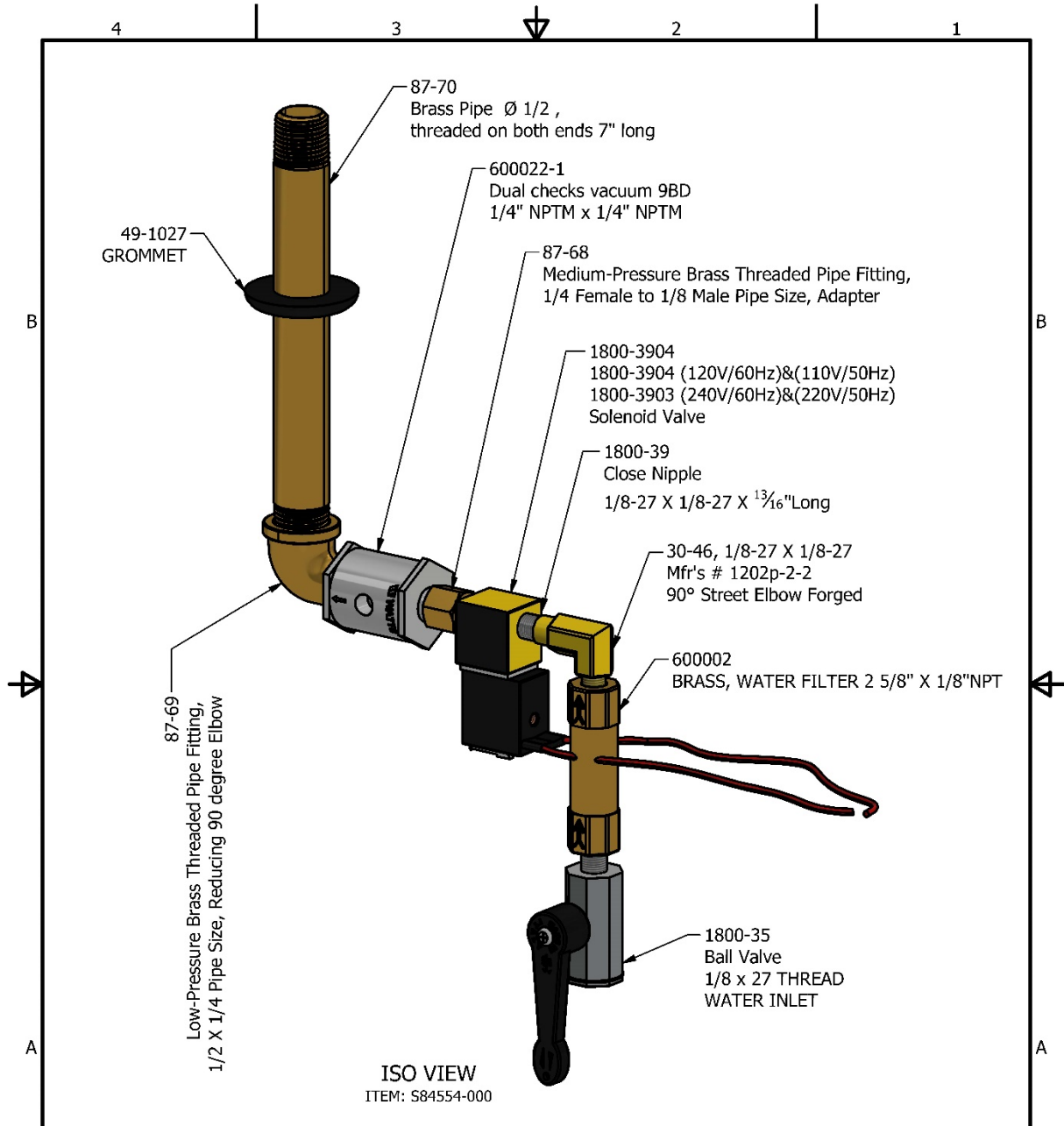

MATERIAL:		DRAWN BY: oiledg		DATE: 10/19/2016		 ATLAS METAL 1135 NW 159TH DRIVE MIAMI, FLORIDA 33169	
CATEGORY: AUTOFILL	TOLERANCES	CHECKED BY: ----		DESCRIPTION: ASSEMBLY, COMPLETE AUTO-FILL			
BREAK ALL SHARP CORNERS PART TO BE FREE OF BURRS.	XXX DECIMAL \pm 0.015	THIS SHEET CONTAINS CONFIDENTIAL INFORMATION, IMAGES AND TRADE SECRETS OF ATLAS METALS, INC. ANY UNAUTHORIZED USE OR DISCLOSURE OF ANY PORTION THEREOF IS STRICTLY PROHIBITED. THIS WORK IS THE EXCLUSIVE PROPERTY OF ATLAS METALS INDUSTRIES, INC. ALL RIGHTS RESERVED.		SIZE: A	PART NUMBER: S84554-000		
UNLESS OTHERWISE SPECIFIED, ALL DIMENSIONS ARE IN INCHES	ANGULARITY \pm 1° UNLESS SPECIFIED ON DRAWING			SHEET No. 2 OF 2	SCALE: ----		

Note - Atlas Metal Industries, Inc. is not responsible for routine maintenance of the strainer or the customer supplied water filter system.

Revised 12.23



ATLAS METAL

Subsidiary of Mercury Aircraft, Inc.

1135 N.W. 159th DR., MIAMI, FL 33169

PHONE (305) 625-2451, (800) 762-7565, FAX (305) 623-0475, E-mail: sales@atlasfoodserv.com

Electric Hot Food Drop-In Trouble Shooting Guide	
Symptom	Probable Cause
Unit will not heat	Unit not plugged in. No power at receptacle. Thermostat and or switch not in the on position. Call factory for service at 1-800-762-7565
Food products not hot enough.	Thermostat's not turned to the highest setting. Food products not hot enough when placed in unit. Food product not being stirred or rotated. Heat lamp or head strip over the food product is recommended. Call factory for service at 1-800-762-7565.
<p style="text-align: center;">NOTE: Before starting any warranty repair work you must first call the factory for authorization. Failure to do so can make you responsible for repair cost.</p>	

REVISION HISTORY		
REV	DESCRIPTION	DATE
1	CHANGE LABLES	2/16/2012

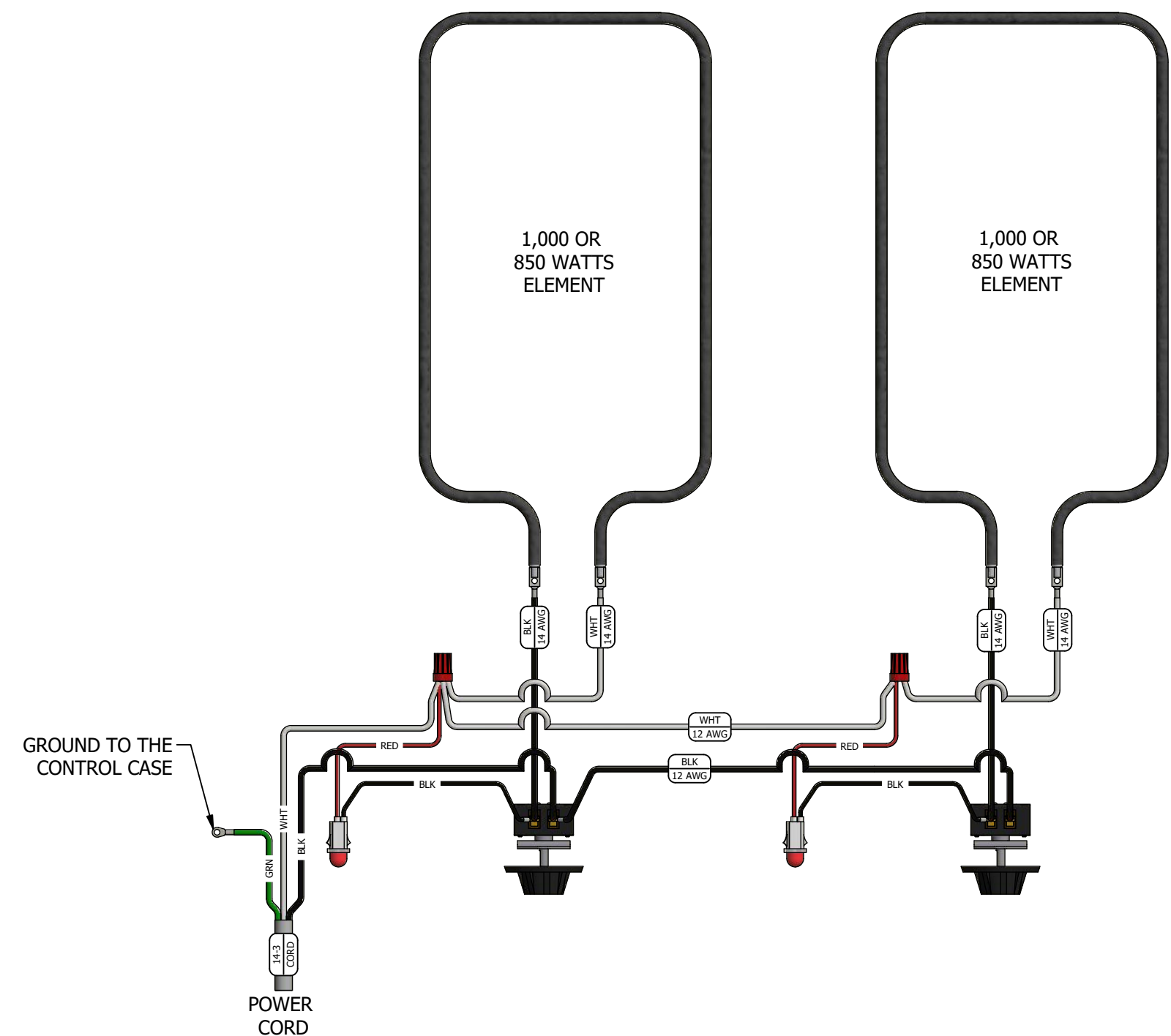

MATERIAL:			
CATEGORY:	TOLERANCES	DRAWN BY:	DATE:
WIH		L.AND	11/30/2010
BREAK ALL SHARP CORNERS. PART TO BE FREE OF BURRS.		CHECKED BY: ----	
UNLESS OTHERWISE SPECIFIED, ALL DIMENSIONS ARE IN INCHES		THIS SHEET CONTAINS CONFIDENTIAL INFORMATION, IMAGES AND TRADE SECRETS OF ATLAS METALS, INC. ANY UNAUTHORIZED USE OR DISCLOSURE OF ANY PORTION THEREOF IS STRICTLY PROHIBITED. THIS WORK IS THE EXCLUSIVE PROPERTY OF ATLAS METALS INDUSTRIES, INC. ALL RIGHTS RESERVED.	



ATLAS METAL
 1135 NW 159TH DRIVE MIAMI, FLORIDA 33169

DESCRIPTION: ELECTRICAL SCHEMATIC

SIZE: B PART NUMBER: WIH-2 120V

SHEET No. 1 OF 1 SCALE: ----

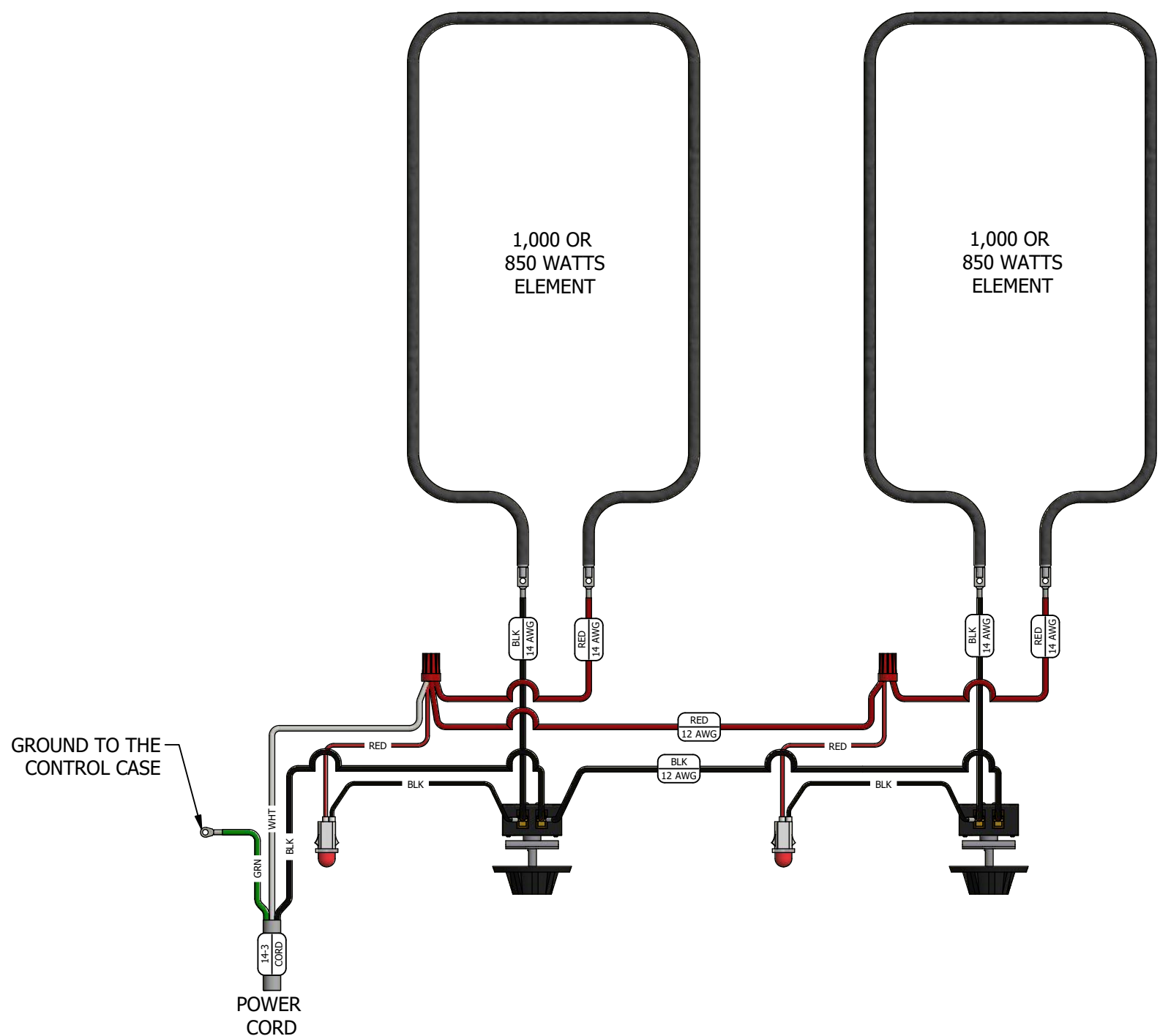
REVISION HISTORY		
REV	DESCRIPTION	DATE
1	CHANGE LABLES	2/16/2012



MATERIAL:		DRAWN BY: L.AND		DATE: 11/30/2010	
CATEGORY: WIH		TOLERANCES		CHECKED BY: ----	
BREAK ALL SHARP CORNERS. PART TO BE FREE OF BURRS.		XXX DECIMAL ± 0.015		THIS SHEET CONTAINS CONFIDENTIAL INFORMATION, IMAGES AND TRADE SECRETS OF ATLAS METALS, INC. ANY UNAUTHORIZED USE OR DISCLOSURE OF ANY PORTION THEREOF IS STRICTLY PROHIBITED. THIS WORK IS THE EXCLUSIVE PROPERTY OF ATLAS METALS INDUSTRIES, INC. ALL RIGHTS RESERVED.	
UNLESS OTHERWISE SPECIFIED, ALL DIMENSIONS ARE IN INCHES		ANGULARITY ± 1° UNLESS SPECIFIED ON DRAWING			
 ATLAS METAL 1135 NW 159TH DRIVE MIAMI, FLORIDA 33169					
DESCRIPTION: ELECTRICAL SCHEMATIC					
SIZE: B		PART NUMBER: WIH-2 208-240V			
SHEET No. 1 OF 1		SCALE: ----			



A T L A S M E T A L

LIMITED WARRANTY

Atlas Metal Industries, Inc. warrants to the Purchaser of this product that the same shall be free from defects in the workmanship and material for a period of one year from the date of original installation of the equipment, but not to exceed eighteen (18) months after date of shipment from factory. During this period of time Atlas Metal Industries, Inc. will replace all defective parts and will pay for authorized replacement labor. Replacement and installation of such parts and labor shall be provided only upon prior written authority of Atlas Metal Industries, Inc.

The Refrigeration warranty is for a twenty (20) month time period and includes supplying the compressor at a no charge basis provided the damage to the compressor was not caused by the customer or end user. Authorized replacement labor will be paid for a period of one year from date of installation. Freight costs for defective unit to and from Atlas Metal Industries, Inc. are not included, and all defective parts must be returned to the factory freight prepaid for evaluation. **ALL WARRANTY LABOR MUST BE AUTHORIZED BY ATLAS METAL INDUSTRIES, INC. PRIOR TO THE ACTUAL WORK BEING DONE.** This warranty does not apply to any equipment or any part thereof, which has been subjected to shipping damage, improper voltage, alteration, abuse or misuses, and does not cover loss of food, other products, or damage to property due to mechanical or electrical malfunction.

THERE ARE NO WARRANTIES WHICH EXTEND BEYOND THE DESCRIPTION OF THE FACE HEREOF. SELLER DISCLAIMS ANY IMPLIED WARRANTY OF MERCHANTABILITY OF THE GOODS OR THE FITNESS OF THE GOODS FOR ANY PURPOSE AND BUYER AGREES THAT THE GOODS ARE SOLD "AS IS."



A T L A S M E T A L

WARRANTY INFORMATION

In order to have your invoice approved for payment by the factory, please note the following:

An authorization number must be obtained from the factory prior to performing any warranty service.

Atlas Metal will not approve excessive labor due to poor access to the unit being serviced. If design does not allow reasonable access, contact the factory.

All travel time that exceeds 100 miles round trip must be authorized by the factory.

**Thank You:
Warranty service Dept.**