



SPEC SHEET

KoolMore 72 in. Commercial Refrigerated Prep Station with Sneeze Guard and Buffet Slide

SKU: KM-RBT-72CSFG

FEATURES

- Commercial Cold Table Refrigerator
- Sneeze Guard and Buffet Slide
- Stainless-Steel Refrigeration Unit
- Automatic Defrost
- Digital Temperature Control
- 1-Year Parts and Labor; 5-Year Compressor Warranty
- Voltage: 115V/60Hz
- ETL Certified for Safety and Sanitation



CLOSE UP IMAGES

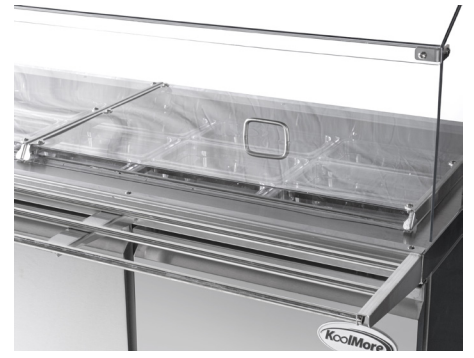

TECHNICAL SPECS

Dimensions

Depth	70.6
Width	29.5
Height	55.2
Interior Depth	19.8
Interior Width	66.6
Interior Height	23.5
D-W-H of Sneeze Guard	71.1 x 29.1 x 21.6
D-W of Rail	70 x 11.1
Depth Including Handles	39.6
Depth Excluding Handles	39.6
Depth Less Door	50.8
Depth With Door Open 90 Degrees	50.8
Power Cord Length	98.5

Capacity

Weight	374
Gross Cubic Feet	21
Net Capacity Cu. Ft.	17.4
Pan Capacity	15 1/3 size
Rail Max Capacity	88 lbs.
Individual Shelf Capacity	88 lbs.

Features & Material

Door Style	Swing
Number Of Doors	3
Number Of Shelves	3
Defrost Type	Automatic
Refrigerant Type	R-290
Temperature Control Type	Digital
Ambient Temperature Range	90 F
Temperature Range	33-40 F
Casters	4
Rail Material	Stainless-Steel
Shelf Material Type	Epoxy Coated
Shelves Adjustable	Yes
Adjustable Pan Dividers	Yes

Electric Data & Certifications

Amps	6.7
Phase	1
Plug Type	NEMA 5-15P
Voltage	115
Hertz	60
Wattage	700
Horsepower	0.7
Certifications	ETL Listed for Safety and Sanitation

Plan View

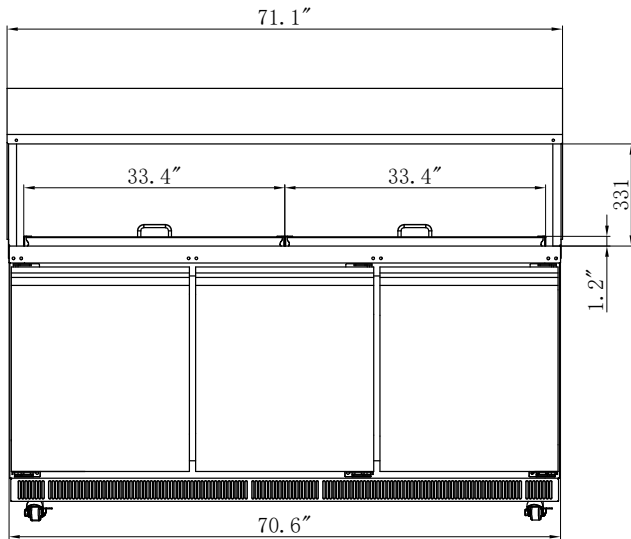

ELEVATION

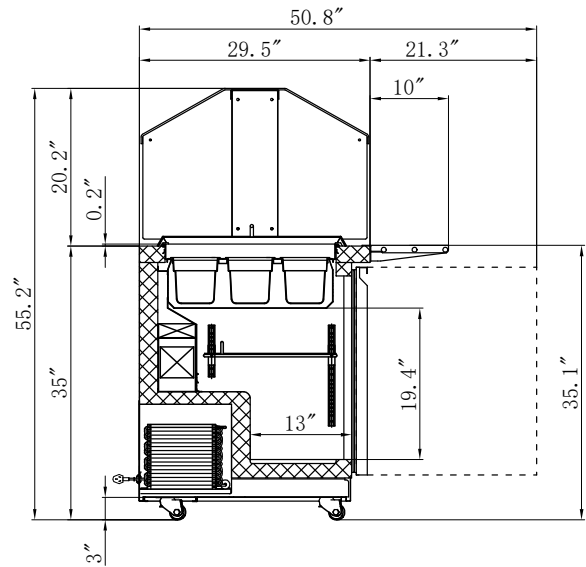

SECTION VIEW

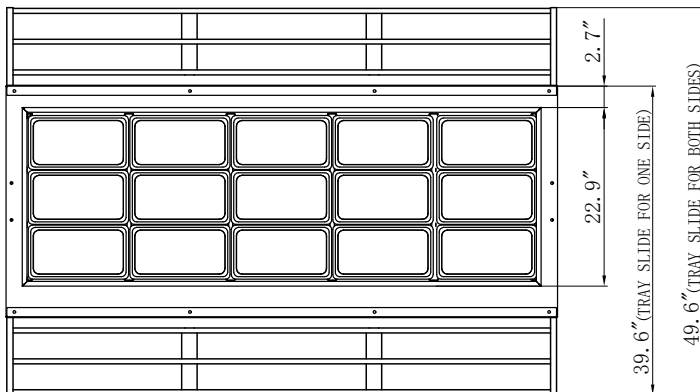

PLAN

CERTIFICATIONS



Intertek



Intertek



706 Eastern Parkway STE 1G, Brooklyn NY 11213
 718-576-6342
 info@koolmore.com