



**John
BOOS**
Since 1887

ITEM #: _____ QTY: _____
 MODEL #: _____
 PROJECT NAME: _____

012420

3601 S. Banker St. Effingham, IL 62401 • P.O. BOX 609 • Ph: (888) 431-2667 • Fax: (800) 433-2667

"DST6-SSW" DISH SORTING TABLE



18GA STAINLESS STEEL TOP AND GALVANIZED BASE W/SHELF & CASTERS

FEATURES:

- STANDARD 16-GAUGE TYPE 300 STAINLESS STEEL TOP WITH #4 POLISH, SATIN FINISH
- 1/2" MPT DRAIN STANDARD
- 2-1/4" RAISED EDGE
- OPTIONAL CASTERS
- NSF CERTIFIED

CONSTRUCTION:

- TOP: STAINLESS STEEL TOPS ARE TIG WELDED, EXPOSED WELDS ARE POLISHED TO MATCH ADJACENT SURFACE

MATERIAL:

- TOP: 16 GAUGE TYPE 300 STAINLESS STEEL WITH #4 POLISH, SATIN FINISH
- LEGS: 1-5/8" ROUND O.D. STAINLESS STEEL
- SHELF: 18 GAUGE STAINLESS STEEL
- GUSSETS: STAINLESS STEEL
- ADJUSTABLE BULLET FEET OR CASTERS



DST6-3049SSW-C

WITH BULLET FEET

MODEL	QTY
DST6-3037SSW	
DST6-3049SSW	
DST6-3061SSW	
DST6-3073SSW	
DST6-3085SSW	
DST6-3097SSW	

WITH CASTERS

MODEL	QTY
DST6-3037SSW-C	
DST6-3049SSW-C	
DST6-3061SSW-C	
DST6-3073SSW-C	
DST6-3085SSW-C	
DST6-3097SSW-C	

DETAILED SPECIFICATIONS

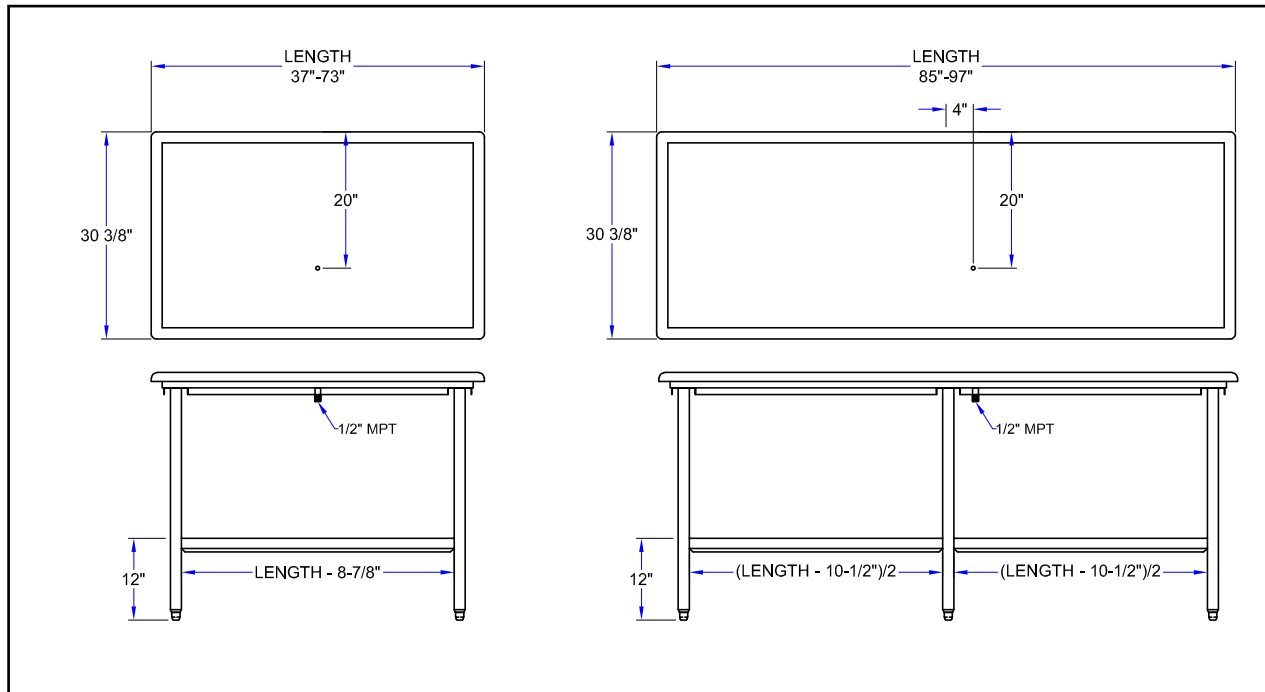

WITH BULLET FEET

MODEL	L	WT
DST6-3037SSW	36-7/8"	68
DST6-3049SSW	48-7/8"	83
DST6-3061SSW	60-7/8"	98
DST6-3073SSW	72-7/8"	113
DST6-3085SSW	85-7/8"	137
DST6-3097SSW	97-7/8"	153

WITH CASTERS

MODEL	L	WT
DST6-3037SSW-C	36-7/8"	68
DST6-3049SSW-C	48-7/8"	83
DST6-3061SSW-C	60-7/8"	98
DST6-3073SSW-C	72-7/8"	113
DST6-3085SSW-C	85-7/8"	137
DST6-3097SSW-C	97-7/8"	153

SOME UNITS SHIP UNASSEMBLED FOR REDUCED SHIPPING COST. ALL DIMENSIONS ARE TYPICAL. TOLERANCE +/- .500"
 John Boos & Co. is constantly engaged in a program of improving products and therefore reserves the right to change specifications without prior notice.



3601 S. Banker St. • Effingham, IL 62401 • PO BOX 609 • quotes@johnboos.com

010620

Boos
lock

AQ AutoQuotes

www.johnboos.com

187