

- **BD3632-IS ARM DUO** 81-3/4"L x 32-1/4"D x 82-5/8"H

### Included

- PO NOTE: ARM Form required at time of PO for DUO lineup
- SHIP NOTE: DUO units ship separately. Lineup required on site.
- Clear glass swinging door w/ left hinge (self-closing)
- LED 4000K top & shelf lights
- Metal shelves (5), lighted (LED) per ARM unit
- One piece formed ABS plastic tub
- One year parts & labor; 5 year compressor warranty
- Shelving removable and adjustable on 1" centers



**BD3632-IS ARM DUO**

Specify	Standard Features	Additional Options
<b>STANDALONE UNIT</b>	• BD3632IS (refrigerated, self-contained)	• BD3632DIS (non-refrigerated)
<b>SATELLITE UNIT</b>	• BD3632SIS (refrigerated, self-contained)	• BD3632DSIS (non-refrigerated)
<b>EXTERIOR COLOR</b>	• Powder coated Silversan Black	
<b>INTERIOR COLOR</b>	• Powder coated Silversan Black	
<b>BASE SUPPORT</b>	• Casters w/ levelers	• Seismic levelers
<b>END PANELS</b>	• Full w/stainless steel mirror interior	
<b>FRONT DOORS</b>	• Clear glass swinging door w/ left hinge (self-closing)	1 • Clear glass swinging door w/ right hinge (self-closing)
<b>VINYL GRAPHICS</b>	• None	• Full wrap graphic set • Logo graphic only
<b>SHELVING</b>	• Metal shelves (5), lighted (LED) per ARM unit	
<b>LIGHTS</b>	• LED 4000K top & shelf lights	
<b>ELECTRICAL CONNECTION</b>	• 6' GFCI straight blade power cord (base exit)	• 6' GFCI locking blade power cord (base exit)
<b>MISCELLANEOUS</b>		• Second year parts & labor warranty (excludes compressor)

Option Notes: 1 - Satellite units only

**Intended Environment:** Type II - Designed to operate in ambient conditions of 80°F and 55% relative humidity unless noted otherwise in system information below.

## PLAN VIEW

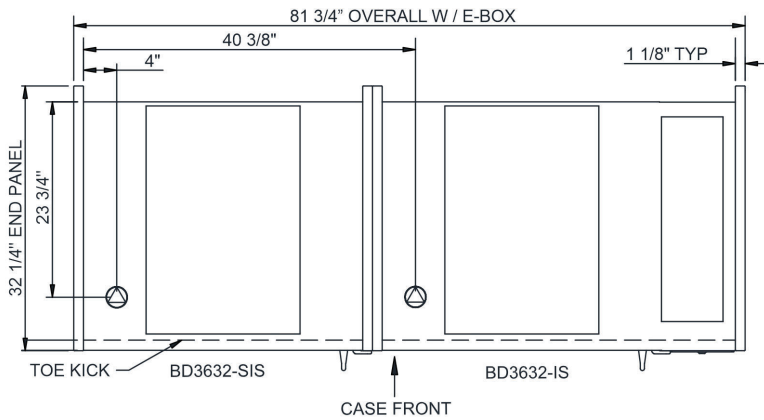

## SIDE VIEW

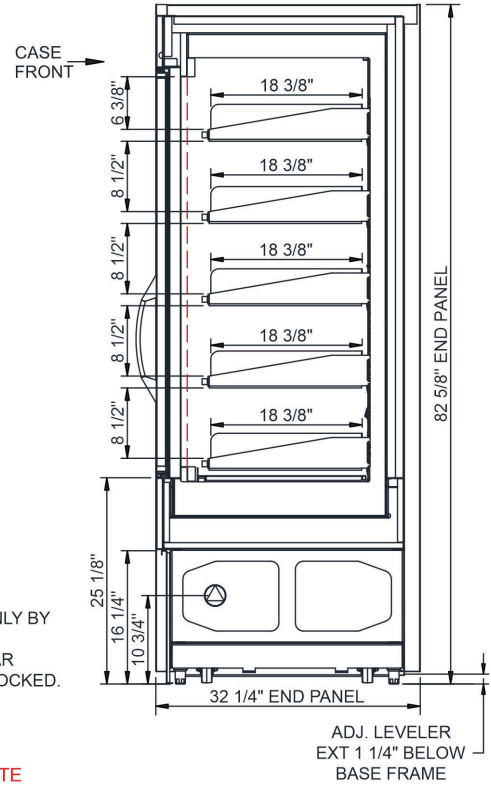

**NOTES:**

1. SHELF TRAY DIMENSIONS: 7 1/4" W X 18 1/4" D
2. BD3632IS, BD3632SIS SELF-CONTAINED ACCESS ONLY BY PULLING OUT CONDENSER DRAWER.
3. COMPRESSOR AIR FRONT INTAKE AND LOWER REAR DISCHARGE. LOWER FRONT PANEL CANNOT BE BLOCKED.

**NOTE: ALL DIMENSIONS APPROXIMATE**

- ELECTRICAL JUNCTION BOX (SUPPLIED WITH 6" LEADS OR POWER CORD).
- LOCATION OF DRAIN TUBE FOR REMOTE REF. ONLY (SUPPLIED WITH 3/4" OR 1 1/2" PVC TUBE).

- REFRIGERATION LINE CONNECTION.
- REMOTE FLOOR SINK & UTILITIES ACCESS AREA.

- SELF-CONTAINED CASE SERVICE ACCESS AREA.
- DRY CASE SERVICE ACCESS AREA.

### Model Technical Specifications

Model	L"	L1"	L2"	System Circuit Volts		Phs	Freq	Amps ***	Watts	Wires	NEMA Plug	SST	Conv. Rack BTUH	Para. Rack BTUH	Est Wt	
BD3632DSIS	33.88	36.38	.00	Ambient/Lights (N/A)	Circuit #1	110-120	1	60	1.70	68	2+G	5-15P or L5-15P	N/A	N/A	N/A	680
BD3632SIS	33.88	36.38	.00	Self-Contained (R290)	Circuit #1	110-120	1	60	11.51	477	2+G	5-15P or L5-15P	N/A	N/A	N/A	800
BD3632DIS	N/A	45.38	.00	Ambient/Lights (N/A)	Circuit #1	110-120	1	60	1.70	68	2+G	5-15P or L5-15P	N/A	N/A	N/A	1,180
BD3632IS	N/A	45.38	.00	Self-Contained (R290)	Circuit #1	110-120	1	60	11.51	477	2+G	5-15P or L5-15P	N/A	N/A	N/A	1,300

\*\*\* Does not include electric defrost on freezer models.

#### Regulatory Approvals: Refrigerated

All Models ETL Listed to UL 541  
ETL Listed to CAN/CSA 22.2 No. 128  
ETL Sanitation to NSF/ANSI 25



#### Regulatory Approvals: Non-Refrigerated

All Models ETL Listed to UL 751  
ETL Listed to CAN/CSA 22.2 No. 128  
ETL Sanitation to NSF/ANSI 25



#### Important Notes:

- 1) ARM Form required at time of PO for this standalone unit w/ E-Box.
- 2) Performance issues (product temperatures, water on floor, etc.) caused by adverse conditions are not covered by warranty.
- 3) Keep unit at least 15' from exterior doors, 10' from overhead HVAC vents, 5' from exterior windows.
- 4) End panels must be tightly joined or kept at least 6" away from any structure to prevent condensation.
- 5) Do not expose unit to direct sunlight or any heat source (ovens, fryers, etc.).
- 6) Tile floors, low ceilings, or small rooms will increase noise level.

**⚠ WARNING:** This product can expose you to chemicals, including Urethane (Ethyl Carbamate), which are known to the State of California to cause cancer and birth defects or other reproductive harm. For more information go to [www.P65Warnings.ca.gov](http://www.P65Warnings.ca.gov).

# ARM Form

<b>To be filled out by End User</b>	
PO Number	
Company Name	
Address	
Contact Person	
Phone Number	
Email Address	
Who will be the Single Point of Contact to set up the Payment System?	
- Name	
- Phone Number	
- Email Address	
Who will be the Single Point of Contact for training of the Instant Systems Software?	
- Name	
- Phone Number	
- Email Address	

<b>To be filled out by Dealer</b>	
PO Number	
Company Name	
Address	
Contact Person	
Phone Number	
Email Address	
Who is the Rep Group Contact?	
- Name	
- Company	

<b>To be filled out by Structural Concepts' OMS team</b>	
SCC Order #	
Requested Ship Date	

<b>To be filled out by Structural Concepts' Success Management team</b>	
Merchant of Record	
Payment Terminal Part #	
Acquirer	
Closed Loop	
License Fee	
Internet Connection	