

"4CS6" MODULAR BASE WORK TABLES

16GA Stainless Steel Top - Sliding Doors

FEATURES:

- Flat Top With 1-1/2" Stallion Edge On Front With 90 Degree Bend Down Side Edge For Table Line-Up
- Top Is Sound Deadened Reinforced With 2"x3" Channel Running Entire Length Of Top
- Stainless Steel Leg With Adjustable Feet
- Optional Fixed (Suffix "-1S") Or Adjustable (Suffix "-1AS") Intermediate Shelf Available
- 36" Working Height
- Shipped Standard Welded Set-Up

SPECIFICATIONS:

- Top: Stainless Steel Cabinet Tops TIG Welded, Exposed Welds Are Polished To Match Adjacent Surface #4 Polished, Satin Finish
- Removable Stainless Steel Legs
- Sliding Doors Are Constructed As Double Panel Doors
- Top: 16GA Type 300 Stainless Steel With #4 Polish, Satin Finish
- Body: 18GA Type 430 Stainless Steel
- Legs: Stainless Steel With Adjustable Feet



CERTIFICATIONS:



4CS6-3048

"4CS6" MODULAR BASE WORK TABLES

LENGTH	24" WIDE	WT (LBS)	30" WIDE	WT (LBS)	36" WIDE	WT (LBS)
48"	4CS6-2448	270	4CS6-3048	295	4CS6-3648	330
60"	4CS6-2460	310	4CS6-3060	335	4CS6-3660	370
72"	4CS6-2472	355	4CS6-3072	375	4CS6-3672	415
84"	4CS6-2484	395	4CS6-3084	415	4CS6-3684	455
96"	4CS6-2496	455	4CS6-3096	460	4CS6-3696	500
108"	4CS6-24108	485	4CS6-30108	460	4CS6-36108	540
120"	4CS6-24120	520	4CS6-30120	500	4CS6-36120	580
132"	4CS6-24132	555	4CS6-30132	608	4CS6-36132	623
144"	4CS6-24144	590	4CS6-30144	635	4CS6-36144	665

ALL DIMENSIONS ARE TYPICAL. TOLERANCE +/- .500". JOHN BOOS & CO. RESERVES THE RIGHT TO CHANGE SPECIFICATIONS WITHOUT NOTICE.

DETAILED SPECIFICATIONS

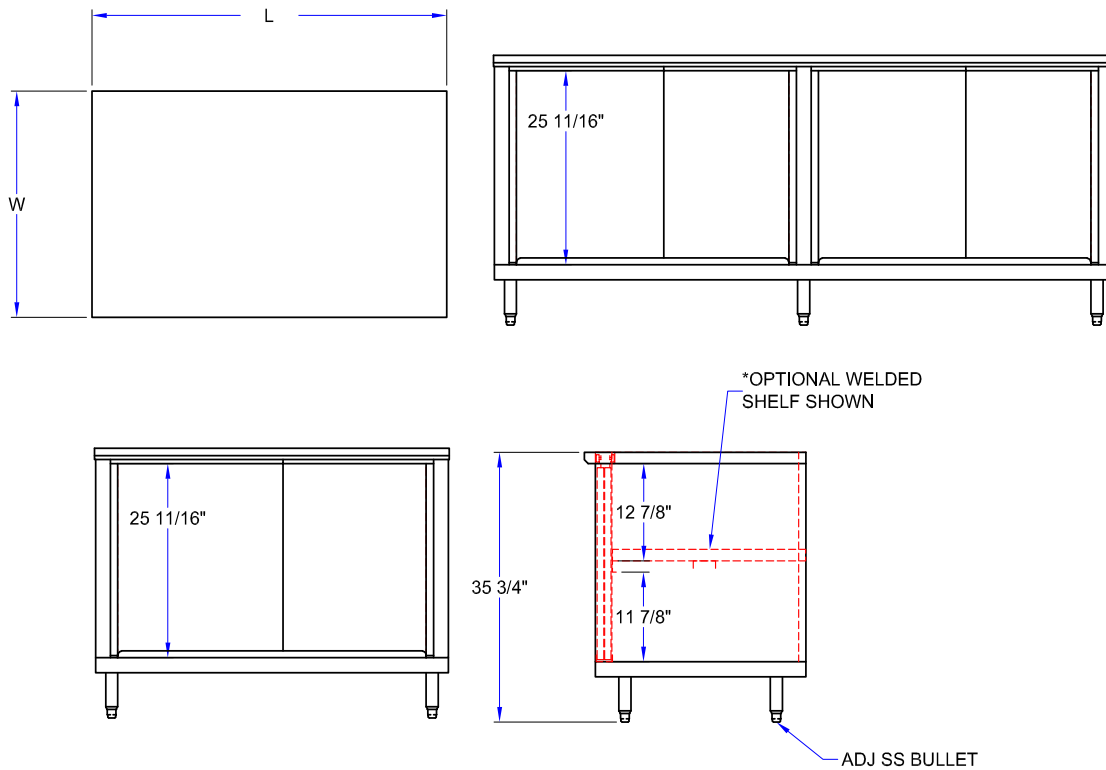

MODEL # STRUCTURE

6 = 16GA Top
 CS = Sliding Doors
 4 = 430 S.S. Body



"4CS6" MODULAR BASE WORK TABLES

LENGTH	24" WIDE	WT (LBS)	30" WIDE	WT (LBS)	36" WIDE	WT (LBS)
48"	4CS6-2448	270	4CS6-3048	295	4CS6-3648	330
60"	4CS6-2460	310	4CS6-3060	335	4CS6-3660	370
72"	4CS6-2472	355	4CS6-3072	375	4CS6-3672	415
84"	4CS6-2484	395	4CS6-3084	415	4CS6-3684	455
96"	4CS6-2496	455	4CS6-3096	460	4CS6-3696	500
108"	4CS6-24108	485	4CS6-30108	460	4CS6-36108	540
120"	4CS6-24120	520	4CS6-30120	500	4CS6-36120	580
132"	4CS6-24132	555	4CS6-30132	608	4CS6-36132	623
144"	4CS6-24144	590	4CS6-30144	635	4CS6-36144	665

ALL DIMENSIONS ARE TYPICAL. TOLERANCE +/- .500". JOHN BOOS & CO. RESERVES THE RIGHT TO CHANGE SPECIFICATIONS WITHOUT NOTICE.