

## SCR610BLCSS

34.0" x 23.63" x 23.5" (H x W x D)

Built-in undercounter commercial beverage center with SS interior and wrapped cabinet

### Highlights:

ETL-S listed to NSF-7 commercial standards

Reversible glass door and LED lighting provide an attractive display

Stainless steel interior ensures long-lasting durability with easy cleanup

Digital controls offer easy and intuitive temperature management



Commercially approved	ETL-S listed to NSF-7 Standards for use in commercial establishments
Built-in capable	Make the best use of space by installing this unit under the counter and flush with other cabinetry
Stainless steel wrapped cabinet	Deluxe style that also enables freestanding use
Glass door	Stainless steel trimmed glass door offers a full display of stored items
Factory installed lock	Keyed lock for a secure interior
Digital thermostat	Intuitive digital controls ensure easy temperature management
Reversible door	User-reversible door swing allows for more flexibility in placing the unit
Adjustable shelves	Rearrange refrigerator space to accommodate all sizes or remove shelves for simple cleanup
Professional handle	Stainless steel handle completes the professional look
Stainless steel interior	Walls are constructed from stainless steel for added strength and easy cleanup

# SCR610BLCSS Specifications:

Height	34.0"
Width	23.63"
Depth	23.5"
Ext Depth with Handle	25.38"
Interior Height 1	26.0"
Interior Width 1	20.0"
Interior Depth 1	17.5"
Comp Step Height	3.75"
Comp Step Width	20.0"
Comp Step Depth	5.0"
Shipping Weight	120.0 lbs.
Weight	110.0 lbs.
Amps	0.8
US Electrical Safety	ETL
Canadian Electrical Safety	ETL-C
Voltage/Frequency	115 V AC/60 Hz
Reversible	Yes
Door Swing	RHD
Shelf Quantity	3
Adjustable Shelf	true
Shelf Type	Chrome
Defrost Type	Automatic
Depth with door at 90°	45.5"
Fan Type	Interior and Exterior
Thermostat Type	Digital
Light	true
Freon Oz	0.99
High Side PSI	270.0
Level Legs Quantity	2
Low Side PSI	105.0
Refrigerant Type	R600a
Parts/Labor Warranty	1 Year
Compressor Warranty	5 Years
Sanitation	ETL-S

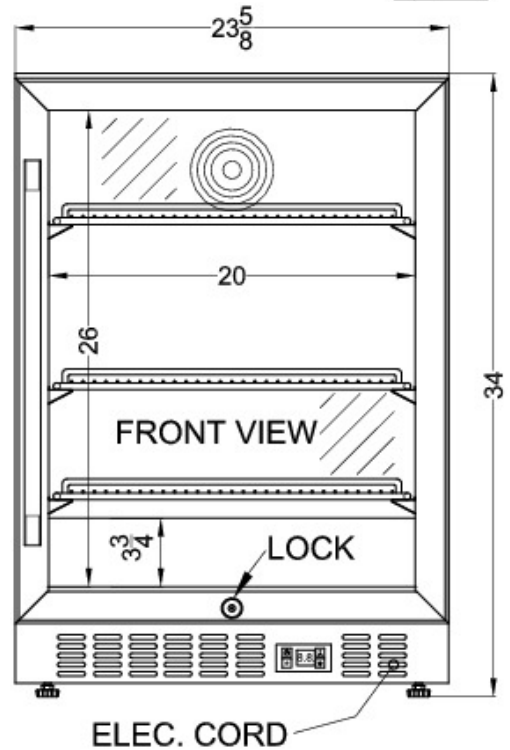
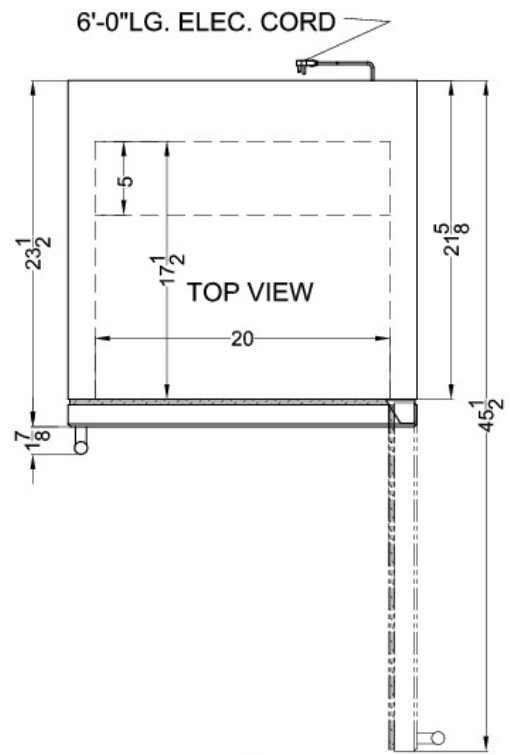

Summit Appliance Division, Felix Storch, Inc.  
 770 Garrison Ave • Bronx, NY 10474  
 Phone: 718-893-3900 • Fax: 718-842-3093  
 Email: info@summitappliance.com