

| | |
|---------------------|------------|
| ITEM #: _____ | QTY: _____ |
| MODEL #: _____ | |
| PROJECT NAME: _____ | |

090319

3601 S. Banker St. Effingham, IL 62401 • P.O. BOX 609 • Ph: (888) 431-2667 • Fax: (800) 433-2667

"4CD4-C" MOBILE DRAWER CABINET



FEATURES:

- 14 GA STAINLESS STEEL FLAT TOP W/FRONT STALLION EDGE
- 18GA TYPE 300 STAINLESS STEEL BASE
- 3 TIER DRAWER (AVAILABLE WITH AND WITHOUT LOCKS)
- REMOVABLE DRAWER PANS
- HEAVY DUTY 5" LOCKING CASTERS
- OVERALL HEIGHT 33-3/4"
- THIS MODEL IS SIZED TO FIT UNDER A 30" DEEP "ST" TABLE WITH BRACING

CONSTRUCTION:

- TOP: STAINLESS STEEL TOPS ARE TIG WELDED, EXPOSED WELDS ARE POLISHED TO MATCH ADJACENT SURFACE

MATERIAL:

- TOP: 14 GAUGE TYPE 300 STAINLESS STEEL
- BASE: 18 GAUGE TYPE 400 STAINLESS STEEL



4CD4-2724-CL



MOBILE DRAWER CABINET

| MODEL | QTY |
|--------------|-----|
| 4CD4-2724-C | |
| 4CD4-2730-C | |
| 4CD4-2724-CL | |
| 4CD4-2730-CL | |

DETAILED SPECIFICATIONS

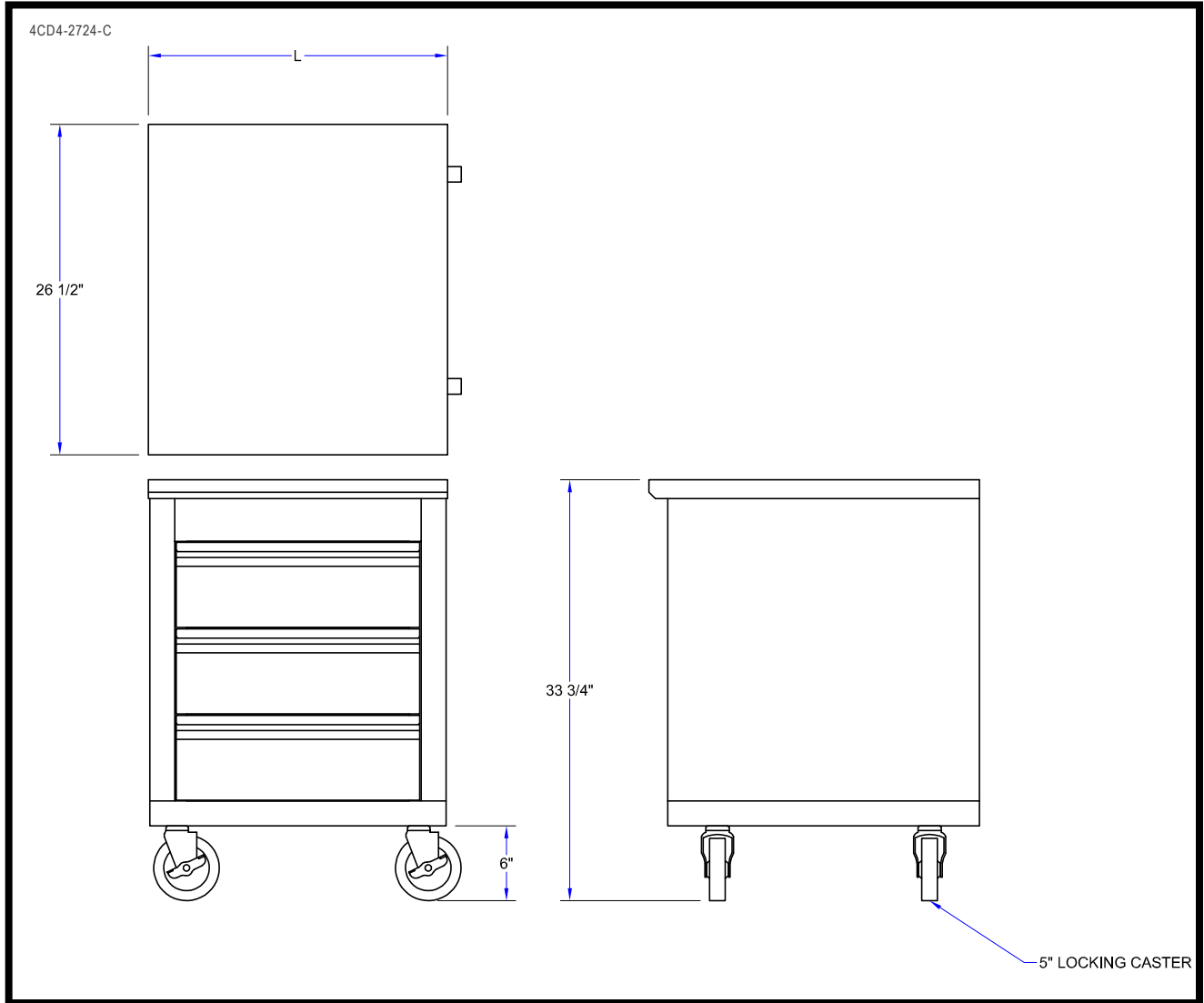

MOBILE DRAWER CABINET WITH CASTERS

| MODEL | L | DESCRIPTION | WEIGHT (LBS) |
|--------------|---------|-------------|--------------|
| 4CD4-2724-C | 24" | NO LOCKS | 140 |
| 4CD4-2730-C | 29-1/2" | NO LOCKS | 167 |
| 4CD4-2724-CL | 24" | WITH LOCKS | 141 |
| 4CD4-2730-CL | 29-1/2" | WITH LOCKS | 168 |

SOME UNITS SHIP UNASSEMBLED FOR REDUCED SHIPPING COST. ALL DIMENSIONS ARE TYPICAL. TOLERANCE +/- .500"
 John Boos & Co. is constantly engaged in a program of improving products and therefore reserves the right to change specifications without prior notice.



Boos
locks

AQ AutoQuotes

3601 S. Banker St. • Effingham, IL 62401 • PO BOX 609 • quotes@johnboos.com

www.johnboos.com

012119

449