



Project _____
 AIA # _____ SIS # _____
 Item # _____ Quantity _____ C.S.I. Section 114000



PR309 Hanging Dial Scale



MODELS

- PR309-1 Hanging Dial Scale
- PR309-3 Hanging Dial Scale

STANDARD FEATURES

- + Full temperature compensating weighing mechanism assures stability in environment changes
- + Dual face charts permits reading weight from both sides
- + Two automatic dampeners; reduces indicator oscillations for quick reading
- + Attractive chrome finished head makes the scale easy to clean
- + Durable stainless steel pan; removable for easy unloading and cleaning
- + Shipping weight 26 lbs.

PR309 HANGING DIAL SCALE

SPECIFIER STATEMENT

The PR309 is a hanging dial scale with removable pan for ease of use and cleaning.

Approved by _____ Date _____ Approved by _____ Date _____

DETAILS AND DIMENSIONS

CHART ILLUSTRATION



30# x 1 oz.
Maximum Capacity 30 lb.
Device No. PR309-1 and PR309-3

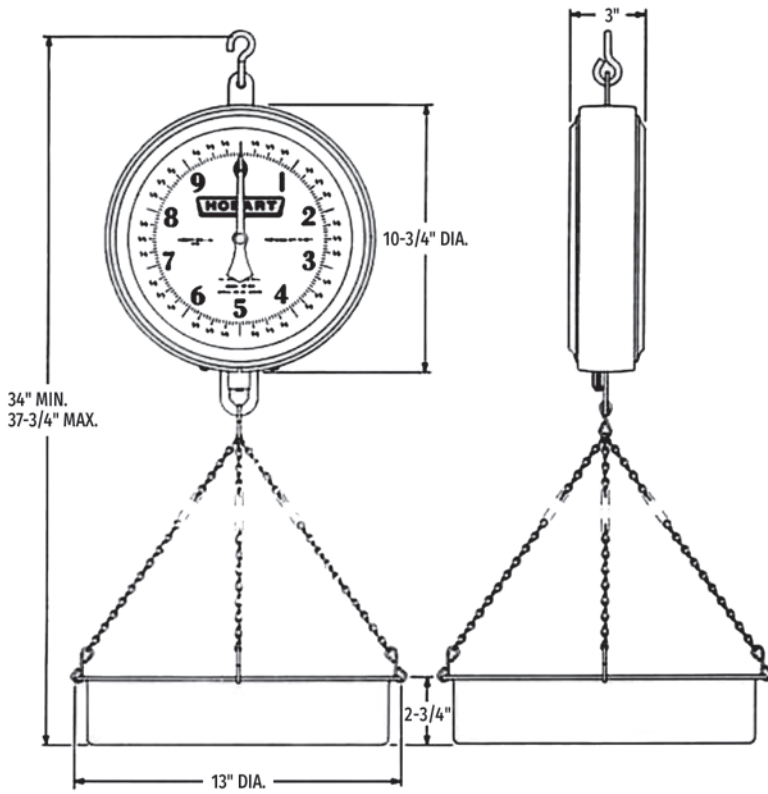

PR309-1

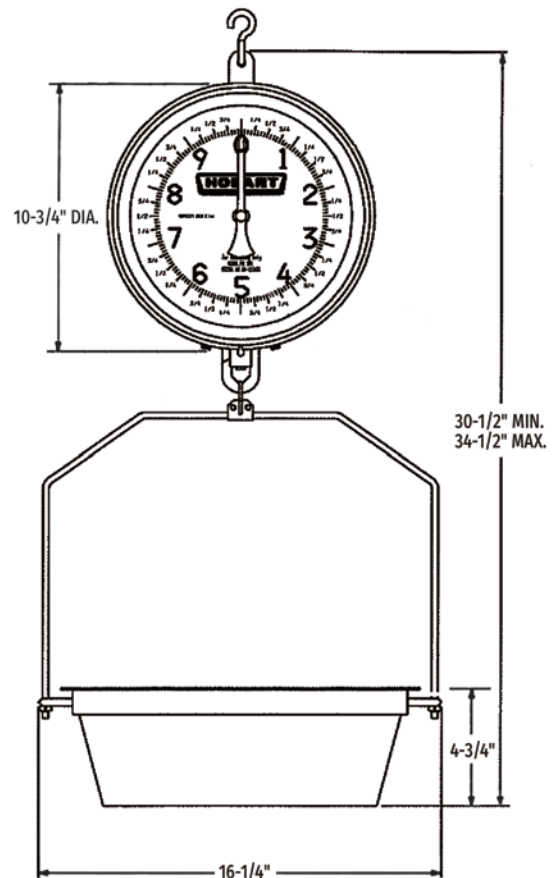

PR309-3

As continued product improvement is a policy of Hobart, specifications are subject to change without notice.