

# Master Series Gas XPress Grill

Project \_\_\_\_\_  
 Item \_\_\_\_\_  
 Quantity \_\_\_\_\_  
 CSI Section 11400  
 Approved \_\_\_\_\_  
 Date \_\_\_\_\_

## Models

- XPG24
- XPG24CE
- XPG24-1L
- XPG24CE-1L



Model XPG24  
Shown with straight grease cans

## Standard Features

- Programmable control for each cooking lane precisely controls:
  - Automatic lifting and lowering of upper platen
  - Cooking gap and time
- EasyTouch™ screen design is simple and intuitive with Press and Go interface
- Advanced temperature control, smart anticipation versus on-off
  - Eliminates temperature overshoot and undershoot
  - Increases temperature uniformity with five independently controlled heat zones -- three on plate and two on platen
  - Each lane can be set to a different temperature for menu flexibility, e.g., all-day breakfast
  - Each lane can be turned Off when not required -- saving energy
- Recipes are programmed by setting grill temperature, platen temperature, cooking gap up to 2 inches (5 cm) and cook time
- USB interface to update menus
- User interface provides advanced diagnostics and error logging for ease

- of service and increased first-time fix
- Stainless steel front, top and sides
- Towel bar with bun pan lip
- Stainless steel dual side grease collectors
- Swivel casters (4) with front brakes
- IPX4 water resistant rating
- Two-year limited parts and labor (USA & Canada)
- Available with 1 upper platen only on either the left or the right; -1L or 1R

## Options & Accessories

- Grease cans are available with
  - straight sides for minimum space
  - flared sides to hold optional tool holders
- Optional tool holders
  - 4-inch spatula
  - 6-inch scrapper
  - 7-inch wiper
- Quick disconnect gas hose 3' (914mm) length

## Specifications

The XPress Grill's upper and lower grill plates cook both sides simultaneously, reducing cook times by up to 50%. Upper grill plate is automatically raised and lowered by a lift system powered by a quiet actuator.

Lower griddle plate made of 3/4" (19mm) thick carbon steel, machine ground and highly polished.

Lower grill plate heated by one electric heating element and two gas burners.

Upper platen heated by nickel plated cast aluminum electric heating elements.

Electric top heater provided with replaceable quick release Teflon sheets. Available in three phase power for Delta or Wye electrical systems.

Voltage sensing and power management automatically adjusts power to electrical system voltage.

Available with CSA approvals for natural or propane gas.

Available with CE approvals for G20, G25 and G31 gas.

All have NSF approval.

**NOTE:** Grills supplied with casters and installed with flexible gas hose must be installed with an approved restraining device.



# Master Series Gas XPress Grill

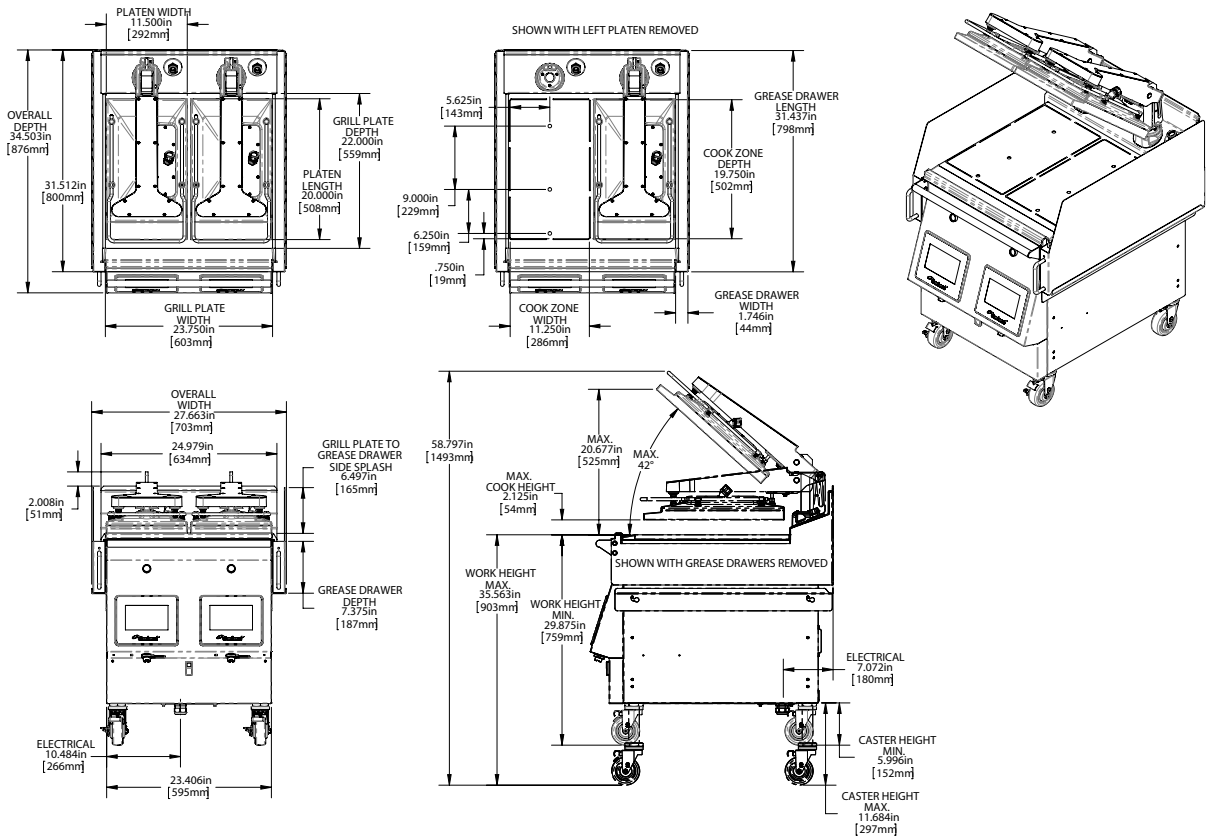

**Gas Input Rating:**  
40,000 BTU

**Supply Pressure:**  
G20 natural gas: 20mbar; G25 natural gas: 25mbar;  
G31 propane gas: 30/37/50mbar

Natural gas 7" WC; Propane 11" WC

Electrical Input Specification -DELTA					
XPG24 CSA Models - Delta					
Model	Volts 3 Ph 50/60 Hz	Total Current (A)			Power (kW)
		L1	L2	L3	
2 Platen	200V	22.9	16.8	28.3	7.0
	208V	20.5	16.5	27.6	7.0
	220V	18.8	15.0	25.1	6.8
	230V	18.0	14.2	23.7	6.9
	240V	17.8	14.1	23.5	6.9
XPG24-1L & XPG24-1R CSA Models - Delta					
Model	Volts 3 Ph 50/60 Hz	Total Current (A)			Power (kW)
		L1	L2	L3	
1 Platen	200V	20.9	4.7	18.4	4.2
	208V	20.25	4.8	18.0	4.3
	220V	18.8	4.7	16.4	4.2
	230V	18.0	4.7	15.6	4.2
	240V	17.8	4.7	15.4	4.2

Electrical Input Specification - WYE					
XPG24 CE Models - WYE					
Model	Volts 3 Ph 50/60 Hz	Total Current (A)			Power (kW)
		L1	L2	L3	
2 Platen	220V/380V	4.7	12.6	15.5	6.8
	230V/400V	4.7	11.8	15.6	6.9
	240V/415V	4.7	11.8	15.6	6.9
		4.7	11.8	15.6	6.9
XPG24-1L & XPG24-1R CE Models - WYE					
Model	Volts 3 Ph 50/60 Hz	Total Current (A)			Power (kW)
		L1	L2	L3	
1 Platen	220V/380V	4.7	0.0	16.7	4.2
	230V/400V	4.7	0.0	15.5	4.2
	240V/415V	4.7	0.0	15.6	4.2

Welbilt reserves the right to make changes to the design or specifications without prior notice.