

## "DSB" WOOD TOP WORK TABLES

*w/Stainless Steel Base & Bracing - 1 3/4" Thick Top w/4" Riser On Back & Sides*

### FEATURES:

- 1-3/4" Thick Northern Hard Rock Maple Top
- Top Is Finished With Penetrating Oil With Optional Natural Clear Varnique Finish (Varnique Finish Voids NSF)
- Stainless Steel Base And Adjustable Bracing
- Adjustable Bullet Feet
- Shipped Knocked-Down, Easy-To-Assemble

### SPECIFICATIONS:

- Top: Northern Hard Rock Maple
- Legs: 16GA Stainless Steel
- Bracing: 1-1/4" Round O.D. 18GA Stainless Steel
- Gussets: Stainless Steel
- Feet: 1" Adjustable Stainless Steel

### CERTIFICATIONS:



### ACCESSORIES

#### DESCRIPTION

Drawer

Drawer Lock

Casters

Overshelves

Pot Rack

### "DSB" WOOD TOP WORK TABLES

LENGTH	24" WIDE	WT (LBS)	30" WIDE	WT (LBS)	36" WIDE	WT (LBS)
48"	<b>DSB01</b>	114	<b>DSB06</b>	136	<b>DSB11</b>	153
60"	<b>DSB02</b>	134	<b>DSB07</b>	157	<b>DSB12</b>	179
72"	<b>DSB03</b>	153	<b>DSB08</b>	179	<b>DSB13</b>	206
84"	<b>DSB03A</b>	172	<b>DSB08A</b>	203	<b>DSB13A</b>	233
96"	<b>DSB04</b>	191	<b>DSB09</b>	226	<b>DSB14</b>	259
108"	<b>DSB04A</b>	215	<b>DSB09A</b>	253	<b>DSB14A</b>	290
120"	<b>DSB05</b>	239	<b>DSB10</b>	280	<b>DSB15</b>	321

ALL DIMENSIONS ARE TYPICAL. TOLERANCE +/- .500". JOHN BOOS & CO. RESERVES THE RIGHT TO CHANGE SPECIFICATIONS WITHOUT NOTICE.

# DETAILED SPECIFICATIONS

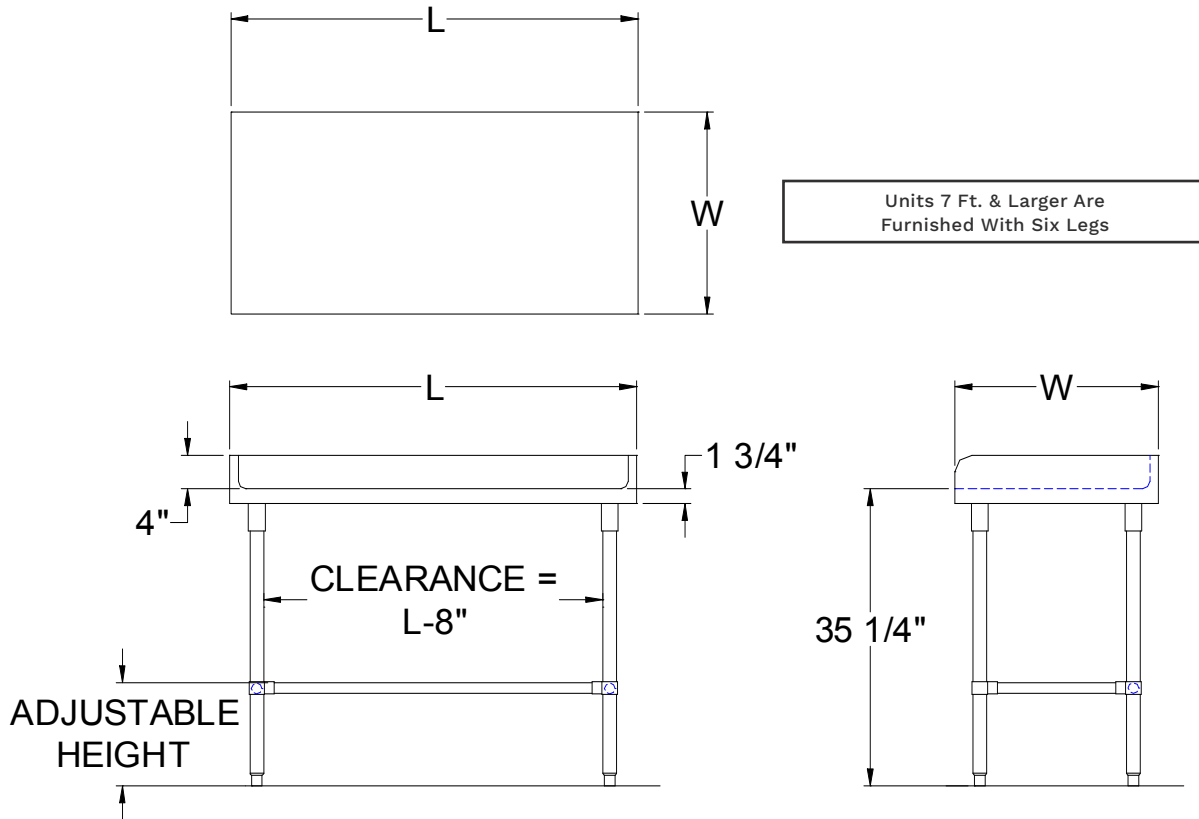

## "DSB" WOOD TOP WORK TABLES

LENGTH	24" WIDE	WT (LBS)	30" WIDE	WT (LBS)	36" WIDE	WT (LBS)
48"	DSB01	114	DSB06	136	DSB11	153
60"	DSB02	134	DSB07	157	DSB12	179
72"	DSB03	153	DSB08	179	DSB13	206
84"	DSB03A	172	DSB08A	203	DSB13A	233
96"	DSB04	191	DSB09	226	DSB14	259
108"	DSB04A	215	DSB09A	253	DSB14A	290
120"	DSB05	239	DSB10	280	DSB15	321

ALL DIMENSIONS ARE TYPICAL. TOLERANCE +/- .500". JOHN BOOS & CO. RESERVES THE RIGHT TO CHANGE SPECIFICATIONS WITHOUT NOTICE.