

Project: \_\_\_\_\_

Item: \_\_\_\_\_

Quantity: \_\_\_\_\_

## Mobile Merchandiser 1407



Designed to display merchandise at multiple angles, this cart can accommodate a variety of products. When not in use, it can easily transport merchandise to the back and can be stored on-end to save space (when not in use).

- All welded construction, Type 6063-T5 aluminum.
- Rectangular tubular base secured with four sheet type gussets with four caster plates welded at each corner and four button bumpers riveted to base front
- Deck constructed of four laterals spaced 4¾" apart and a 2" lip welded to hinged end of deck.
- Stand consists of rounded channel welded perpendicular to length of unit to secure display position.
- Four plate type casters; two 1⅜" x 5" swivel, two 2" x 5" rigid with brake.
- Five-Year Guarantee against material defects and workmanship.
- Lifetime Guarantee against rust and corrosion.

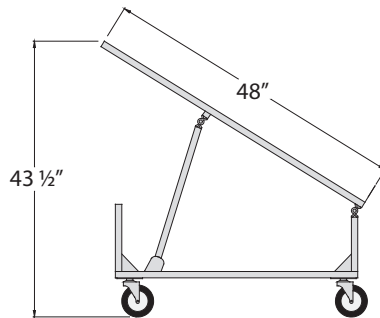
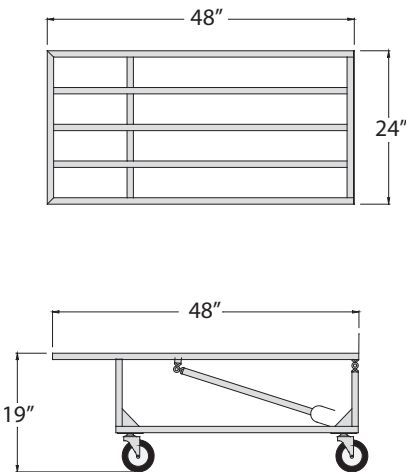

### ► Mobile Merchandiser

Model No.	Position	Size L-H-W	Weight Capacity	Ship Lbs.
1407	Upright / Display	43" x 43½" x 24"	1000 lbs.	45
	Flat / Storage	48" x 19" x 24"		

Four heavy duty plate type casters; two 1⅜" x 5" swivel, two 2" x 5" rigid with brake.



New Age Industrial Corp., Inc. || [NewAgeIndustrial.com](http://NewAgeIndustrial.com) || Made in the USA

PO Box 520 • 16788 US Hwy 36 • Norton, Kansas 67654 || Phone: (800) 255-0104 • (785) 877-5121 || Fax: (877)-877-7687 • (785) 877-2616

This information is for general sales and engineering use only. New Age Industrial reserves the right to modify or make changes at any time, without notice, to materials and specifications.