



Horizon Elite™

self-contained 1010, 1410 series Chewblet® ice machine

Features

High performance Horizon Elite ice machines

- 1010 series - up to 1061 lb (482 kg) in 24 hours
- 1410 series - up to 1466 lb (665 kg) in 24 hours
- automatically transport ice through a tube with RIDE® technology from up to 75' (22.9 m) away
- chewable, compressed nugget ice is preferred over cubes¹
- ice dispenses reliably from ice and beverage dispensers
- available with approximately 1.00" (2.54 cm) long standard Chewblet ice or optional 3/8" (0.95 cm) long Micro Chewblet™ ice
- quiet production without noisy harvest cycles

Revolutionary, scale inhibiting design

- produces ice that has 15% the TDS of the incoming water for optimum dispensing and long life in drinks
- quarantines and regularly expels scale producing dissolved solids to dramatically reduce scale buildup
- increases time between descaling and reduces or eliminates the need for expensive scale treatment
- saves 35% water compared to comparable cubers

Durable, attractive ice machine

- regular bearing inspection or replacement is not required
- upgraded, easy-to-read LED operating status and diagnostic display

Designed with sanitation in mind

- Agion® silver-based antimicrobial product protection of key ice and water contact components²
- floatless, sealed design inhibits formation of biofilms
- semi-automatic cleaning and sanitizing system

Remote monitoring with Open Kitchen™

- provided in partnership with Powerhouse Dynamics (separate subscription required)
- real-time alerts and notifications
- remote diagnostics to maximize equipment uptime
- connects with equipment across other Middleby brands

Warranty

- 3 years parts and labor, 5 years compressor parts³

Certifications



Model configurations					
For use with ¹	Install/mount	Condenser	V/Hz/Ph	Item number ² 1010 series	Item number ² 1410 series
ice storage bin	top mount	air	208-230/60/1	HCC1010ABT	HCC1410ABT
		water	208-230/60/1	HCC1010WBT	HCC1410WBT
	RIDE	air	208-230/60/1	HCC1010ABS	HCC1410ABS
		water	208-230/60/1	HCC1010WBS	HCC1410WBS
Follett Vision™ undercounter ice and beverage dispenser	RIDE	air	208-230/60/1	HCC1010AVS	HCC1410AVS
		water	208-230/60/1	HCC1010WVS	HCC1410WVS
countertop ice and beverage dispenser (by others) and Follett Ice Manager ⁴	top mount ³	air	208-230/60/1	HCC1010AHT	HCC1410AHT
		water	208-230/60/1	HCC1010WHT	HCC1410WHT
	RIDE	air	208-230/60/1	HCC1010AHS	HCC1410AHS
		water	208-230/60/1	HCC1010WHS	HCC1410WHS
drop-in dispenser (by others)	RIDE	air	208-230/60/1	HCC1010AJS	HCC1410AJS
		water	208-230/60/1	HCC1010WJS	HCC1410WJS

¹ Ordered separately.
² For Micro Chewblet ice, replace second character (C) with an M e.g. HMC1010ABT.
³ Requires top kit (see page 4 for item number).
⁴ Refer to form# 1050 for Ice Manager details and requirements.

Options and accessories

- Top kit for ice and beverage dispensers (listed on page 4)
- Water filters (refer to form# 9905)
- Wall mount bracket (item# 01085455)
- Ice machine stand, height-adjustable (item# 01085463)
- Timer to control one or two ice machines (item# 00967265)
- Longer ice transport tube (refer to the price list, form# 4025)
NOTE: 10' (3 m) provided as standard for RIDE model.
- Sleep cycle kit for improved energy efficiency and component life.
For countertop dispenser applications (item# 01338276).
- SafeCLEAN Plus™ ice machine cleaner
 - 1 x 8 oz (237 ml) bottle (item# 01147826)
 - 6 x 8 oz (237 ml) bottles (item# 01149954)
 - 24 x 8 oz (237 ml) bottles (item# 01149962)
 - SaniSponge™, 24 sanitary sponges (item# 01075431)
- Three year remote monitoring subscription and hardware for Open Kitchen (item# MDD-1003)
NOTE: For serial number Q34181 and above.
- For additional accessories, refer to form# 4025

¹ Independent third party studies. Contact Follett for details.

² Disclaimer: Antimicrobial protection is limited to the treated components and does not treat water or ice.

³ Refer to price list for additional warranty information.

Dimensional drawing

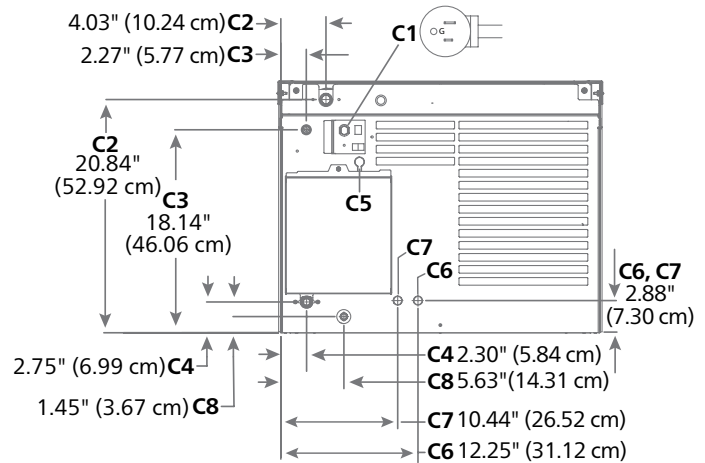
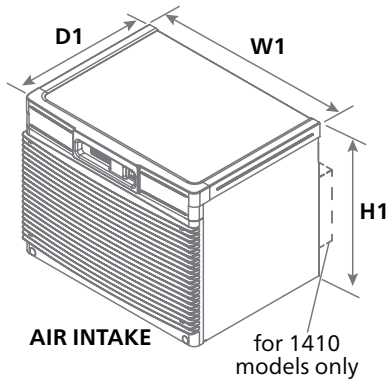

Specification

W1 Width	29.15" (74.0 cm)
D1 Depth	1010 series: 23.25" (59.1 cm) 1410 series: 25.15" (63.9 cm)
H1 Height	22.50" (57.2 cm)
Clearance	top, left and right – 1.00" (2.54 cm)
C1 Electrical	1010 series: 11 amps, requires dedicated 15 amp circuit, 6' (1.8 m) cord, NEMA 6-15 plug 208-230 V/60/1 1410 series: 14 amps, requires dedicated 20 amp circuit, 6' (1.8 m) cord, NEMA 6-20 plug
Operating power	1010 series: 2.4 kW 1410 series: 3.1 kW
C2 Ice transport tube	see page 8 for details
C3 Water inlet	3/8" OD push-in water inlet – internal connection
C4 Drain	3/4" MPT, 1" drain required. See page 7 for details.
C5 Ice bin signal cord	for Vision applications only
Water-cooled ice machine connections	C6 – 1/4" FPT condenser inlet C7 – 1/4" FPT condenser outlet
C8 Auxiliary drain (required)	3/8" OD push-in
Air temperature	50 -100 F (10 - 38 C)
Water temperature	45 - 90 F (7 - 32 C)
Potable water pressure	10 - 70 psi (69 - 483 kPa)
Condenser water pressure	30 - 150 psi (207-1034 kPa)
Ice production	see page 8
Energy consumption	1010 series: air-cooled – 4.80 kWh, water-cooled models – 4.20 kWh 90 F (32 C) air, 70 F (21 C) water 1410 series: air-cooled – 4.84 kWh, water-cooled models – 3.80 kWh per 100 lb (45.4 kg) ice
Heat rejection	1010 series: air-cooled – 11,300 BTU/hr (2,849 Kcal/hr), water-cooled – 12,800 BTU/hr (3,228 Kcal/hr) 1410 series: air-cooled – 16,000 BTU/hr (4,035 Kcal/hr), water-cooled – 16,400 BTU/hr (4,135 Kcal/hr)
Water consumption	12.0 gal (45 L) of potable water per 100 lb (45.4 kg) of ice (per AHRI test standards). 12.4 gal (46.9 L) for 1010 series or 12.3 gal (46.5 L) for 1410 series at low TDS flush setting.
Water flow requirement for water-cooled models	1 gallon per minute
Refrigerant	R404a
Approximate ship weight	1010 series: 275 lb (125 kg), 1410 series: 285 lb (129 kg)
Approximate net weight	1010 series: 237 lb (108 kg), 1410 series: 247 lb (112 kg)
NOTE: For indoor use only	

SHORT FORM SPECIFICATION: Follett® Horizon Elite ice machine model _____ capable of producing compressed nugget ice using an efficient, sanitary horizontal evaporator/auger system and delivering ice by a flexible wire reinforced transport tube to _____ ice storage bin, _____ ice and water dispenser, _____ ice and beverage dispenser, _____ drop-in dispenser or _____ Ice Manager™ diverter valve system. Slide-out compressor/condenser/evaporator with utility docking station, front-mounted unit status display, evaporator water inlet at harvest end with automatic flush while producing ice, and semi-automatic cleaning and sanitizing system.

1 – Locating the ice machine

Horizon Elite self-contained Chewblet ice machines allow top-mounting or mounting in a base cabinet, on a wall or on a floor stand up to 75' (22.9 m) from the dispenser or ice bin with RIDE technology. In-cabinet mounting (RIDE applications) require special attention to service access, unit ventilation and ice tube runs (see pages 4-8).

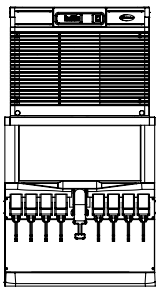
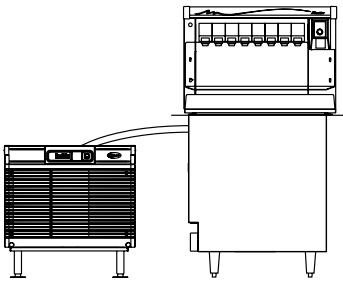
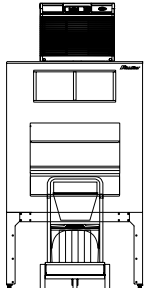
<p>Top mounting – ice and beverage dispensers (by others)</p>	<p>RIDE model – Follett low-profile Vision ice and beverage dispensers</p>	<p>Top mount on Follett ice storage bins</p>
		
<p>Important specifier notes</p> <ol style="list-style-type: none"> 1. Dispenser must be compatible with nugget ice. See page 4 for compatible ice and beverage dispenser models and top kit numbers. 2. Verify ceiling or soffit height to ensure sufficient top clearance. 	<p>Important specifier notes</p> <ol style="list-style-type: none"> 1. See page 4-6 for critical clearance and venting requirements. 2. Ice transport tube ships with Vision ice and beverage dispenser (Vision applications only). 	<p>Important specifier notes</p> <ol style="list-style-type: none"> 1. See form# 8590 for bin sizing. 2. Verify ceiling or soffit height to ensure top clearance. 3. Locate floor sink or grate and drains in front of storage bin. 4. Do not position bin drain lines to block Ice•Devlce™ bin cart.

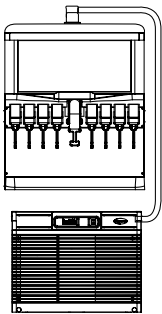
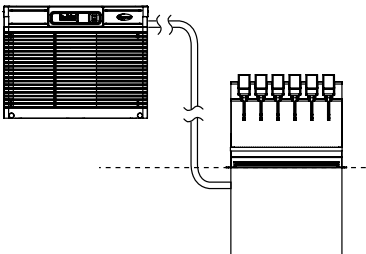
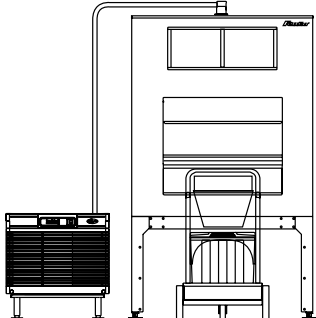
<p>RIDE model – ice and beverage dispensers (by others)</p>	<p>RIDE model – drop-in beverage dispensers (by others)</p>	<p>RIDE model – Follett ice storage bins</p>
		
<p>Important specifier notes</p> <ol style="list-style-type: none"> 1. Dispenser must be compatible with nugget ice. Compatible dispensers include Coca-Cola Freestyle 9000, Cornelius DB/ID/DF150/175, Lancer 4500-22N, FS-16N, FS-22N and FS-44N, Servend MD150/175/200/250, SV175/200/250, MDH-402 and Follett Symphony Plus™ 110CM, as well as dispensers listed on page 4. 2. Coca-Cola Freestyle 7100 requires top adapter IC Code 46751 and ice kit IC Code 46430 only, and must be ordered from Coca-Cola. Coca-Cola Freestyle 9100 requires top kit HSF26SC. Consult with Coca-Cola and Follett to qualify application prior to ordering. 3. RIDE application is approved only for Pepsi Spire 3.0, 5.0 and 4.1 designed for top mount ice machines and requires MSP24SC for 3.0 and MSP30SC for 5.0 and 4.1, ordered separately. For manual fill versions of Pepsi Spire 3.0, 5.0 and 4.1, contact factory. 4. See page 4-6 for critical clearance and venting requirements. 	<p>Important specifier notes</p> <ol style="list-style-type: none"> 1. Compatible with the following dispensers: Cornelius 1522, 1722, 2323, and Lancer 2200, 2300, 23300. 2. Require 12.00" (30.5 cm) of access space for installation on transport tube side. 3. See page 4-6 for critical clearance requirements. 	<p>Important specifier notes</p> <ol style="list-style-type: none"> 1. See form# 8590 for bin sizing. 2. Locate floor sink or grate and drains in front of storage bin. 3. Do not position bin drain lines to block Ice•Devlce bin cart.

1 – Locating the ice machine (continued)

Top mounting – compatible ice and beverage dispensers ¹

Manufacturer	Model number	Width in (cm)	Depth ² in (cm)	Height ³ in (cm)	Top kit
Coca-Cola dispensers	Freestyle 7000	30.10 (76.5)	33.11 (84.1)	47.00 (119.38)	H30F30-F ⁴
	Freestyle 7100	30.00 (76.2)	33.80 (85.8)	47.00 (119.4)	H30F30-F ^{4,5}
Cornelius dispensers	DB/ED/DF 200 series	30.00 (76.2)	30.00 (76.2)	34.38 (87.3)	H30C30-F
	DB/ED/DF 250 series	30.00 (76.2)	30.00 (76.2)	38.38 (97.5)	H30C30-F
	DB/ED/DF 300 series	44.00 (111.8)	30.00 (76.2)	34.00 (86.4)	H30C44-(F or B) ⁶
	FlavorFusion / Overload	30.00 (76.2)	33.13 (84.2)	39.38 (100.0)	H30C30-F-FF
	IDC215	30.00 (76.2)	33.13 (84.2)	39.38 (100.0)	H30C30-F-IDC
	IDC255 and Pro Fast Gate	30.00 (76.2)	33.13 (84.2)	36.38 (92.4)	H30C30-F-IDC
	IDC Pro	30.00 (76.2)	33.13 (84.2)	40.25 (102.2)	H30C30-X-PRO ⁷
Lancer dispensers	4500-30N	30.00 (76.2)	30.50 (77.5)	36.50 (92.7)	H30L30-F
	FS-30N	30.00 (76.2)	30.50 (77.5)	42.13 (107.0)	H30L30-F
	Bevariety	30.00 (76.2)	31.00 (78.7)	37.75 (95.9)	H22L30-F-STP
	Sensation 30"	30.00 (76.2)	31.00 (78.7)	38.25 (97.2)	H30L30-F-STP
	Sensation 44"	44.00 (111.8)	31.00 (78.7)	39.38 (100.0)	H22L44-F-STP
	Touchpoint	32.50 (82.6)	33.70 (85.6)	40.00 (101.6)	H30L30-F-STP
Pepsi dispensers	Spire 5.0 / 4.1	30.50 (77.5)	36.00 (91.4)	42.75 (108.6)	H30P30-F
Servend dispensers	MDH-302	42.80 (108.7)	31.00 (78.7)	32.38 (82.2)	H30S44-(F or B) ⁶

¹ All approved dispensers can be filled with a RIDE model Horizon Elite ice machine without a top kit except for Pepsi Spire 3.0, 5.0 and 4.1, see page 3 for details.

² Requires minimum 1.00" (2.54 cm) clearance between back of dispenser and wall.

³ Net height after installation of top kit (excluding height of ice machine).

⁴ Consult with Coca-Cola and Follett to qualify application prior to ordering.

⁵ Top adapter IC Code 46753 and ice kit IC Code 46430 must also be ordered from Coca-Cola.

⁶ Specify "F" for front facing, or "B" for backward facing units.

⁷ Top designed with flexibility to accommodate front or back mounting.

2 – Undercounter/in-cabinet mounting

Cabinet details

Important specifier notes

1. Cabinet door opening must meet minimum size requirements shown and be free of obstructions to allow ice machine to slide out (no lip or utilities to block removal).
2. Cabinet base must be capable of supporting ice machine and allow ice machine to rest flat on cabinet bottom.
3. No counter supports, electric or plumbing can run in front of the ice machine.

Cabinet door opening

1010/1410 series models require 1.00" (2.54 cm) all around, 31.00"W x 23.5"H (78.7 cm x 59.69 cm) minimum

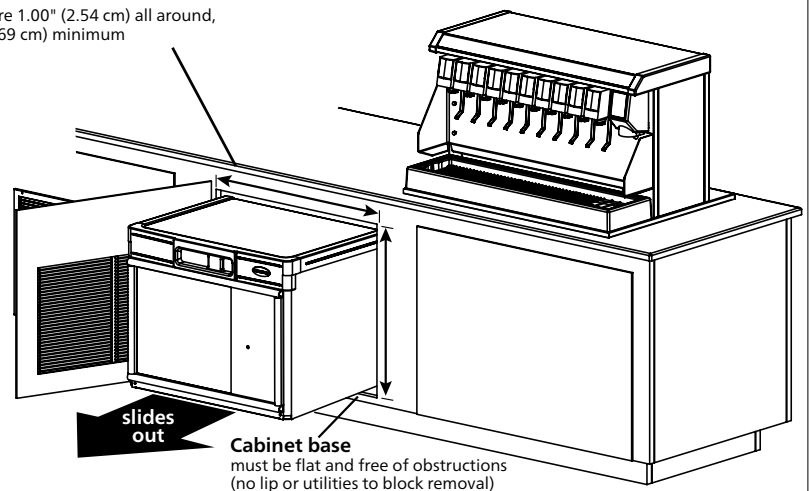

3 – Undercounter/in-cabinet mounting and ventilation

Using Follett supplied grilles

Horizon Elite ice machines can be installed undercounter/in-cabinet to fill bins or dispensers using RIDE technology. Care must be taken to ensure proper cabinet venting to avoid recirculation of hot air. Improper venting can cause ice machine outages.

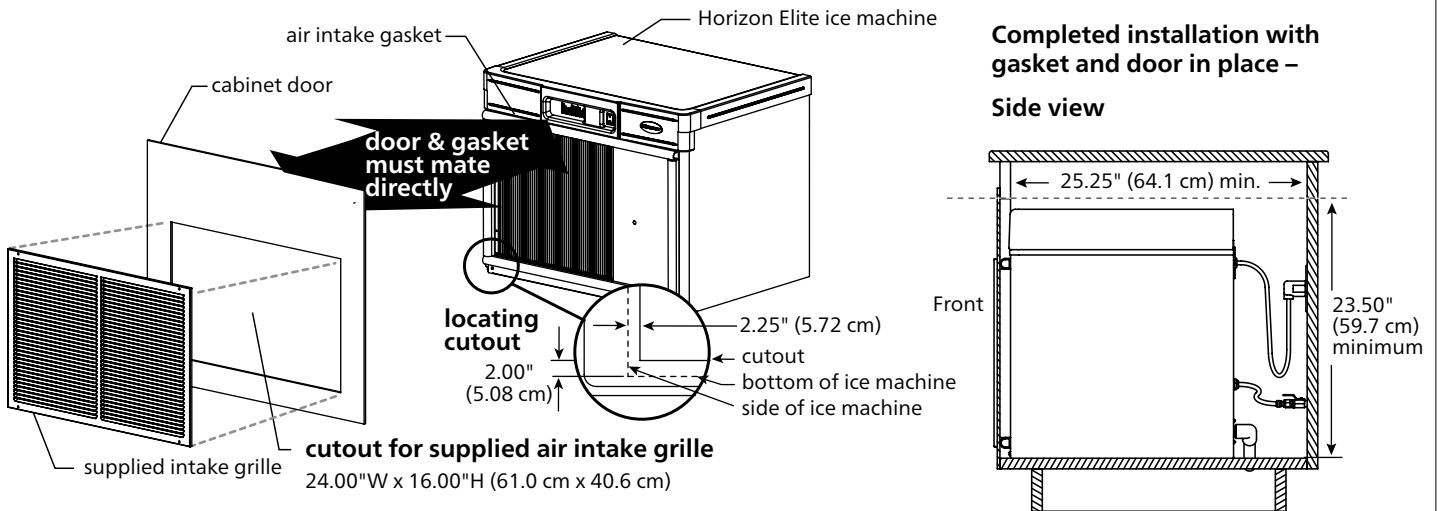
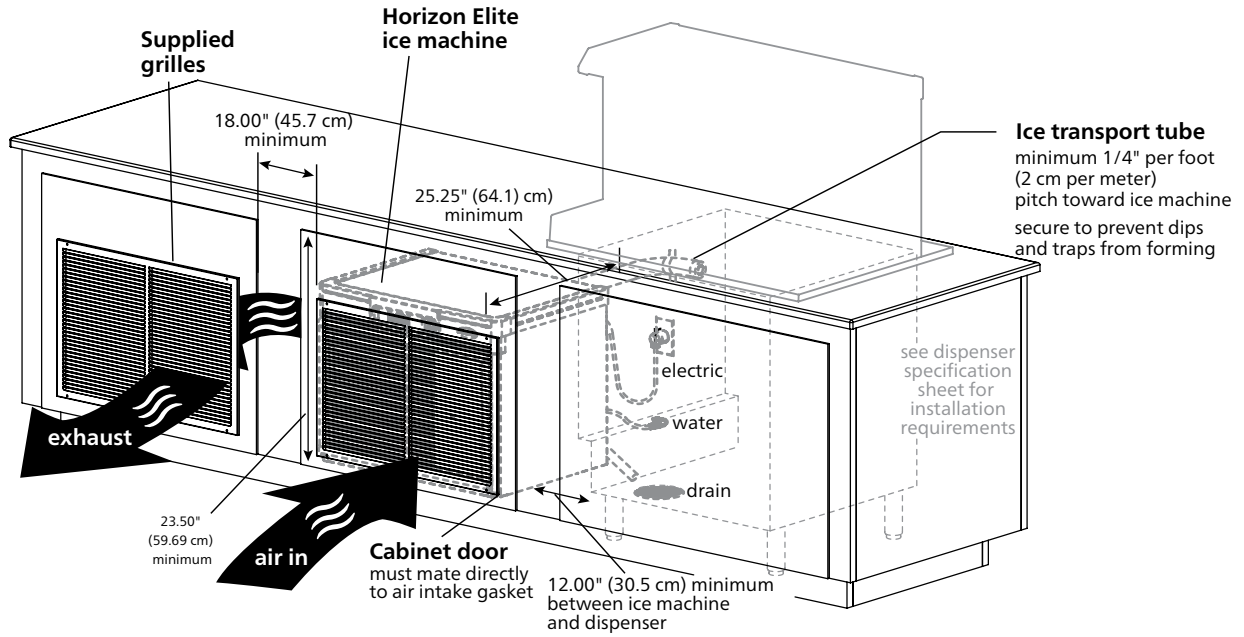

Important specifier notes for using Follett supplied grilles

1. The supplied exhaust grille must be located at least 18.00" (45.7 cm) from the supplied air intake grille (exhaust air must not recirculate with intake air).
2. Cabinet interior must be open to allow for unrestricted exhaust air flow.
3. Ice transport tube needs minimum 1/4" per foot (2 cm per meter) pitch toward ice machine and should be secured to prevent dips and traps from forming.
4. Cabinet door must mate directly to air intake gasket.
5. Cabinet interior must provide a minimum clear space of 23.50" (59.7 cm) high by 25.25" (64.1 cm) deep.
6. Cutout for supplied grilles must meet minimum size requirements shown above.
7. Utilities should be conveniently located as shown.

3 – Undercounter/in-cabinet mounting and ventilation (continued)

Using grilles by others/alternate cabinet ventilation

Cabinets with ventilation or louvers other than those provided require special consideration to provide proper ventilation. Recirculation of hot air will reduce ice machine performance and can cause ice machine outages.

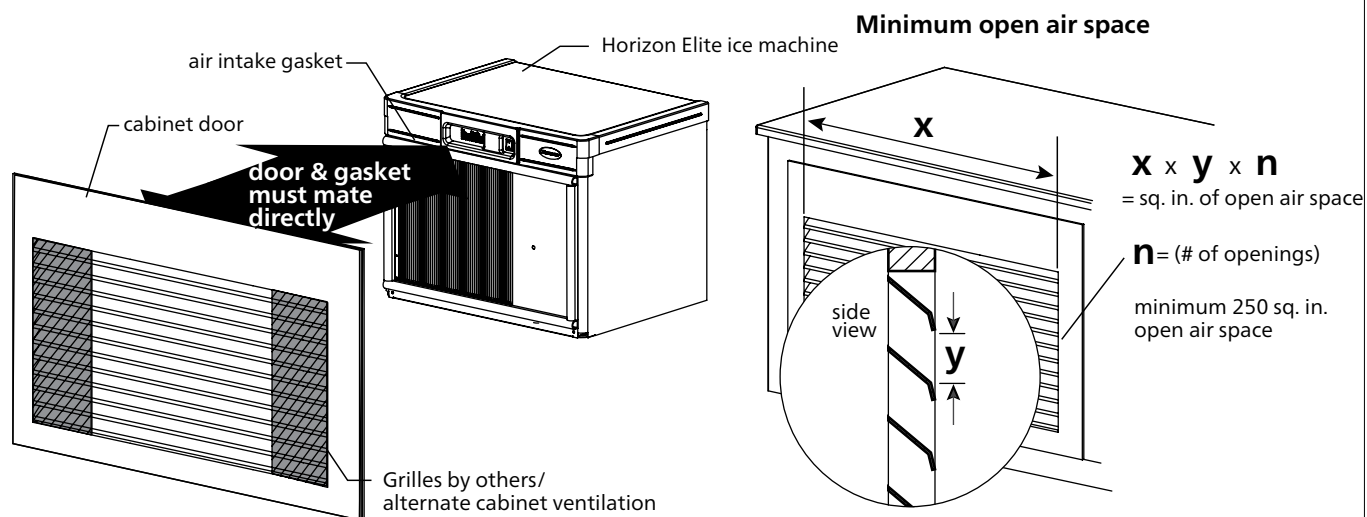
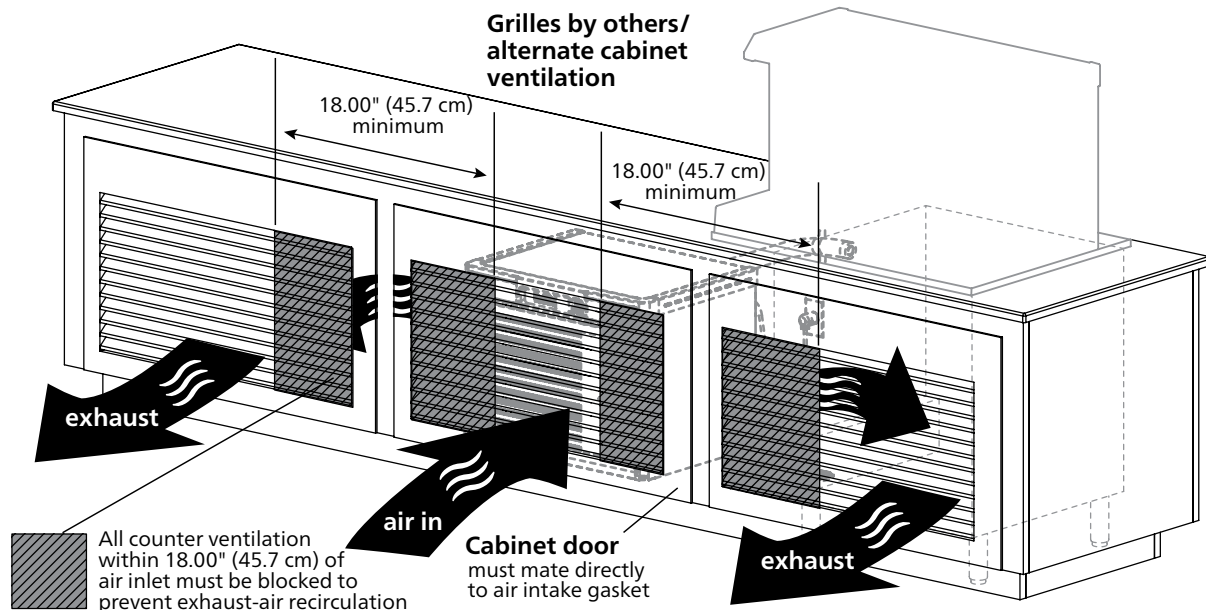

Important specifier notes for using grilles supplied by others/alternate cabinet ventilation

1. Exhaust must be at least 18.00" (45.7 cm) from air intake (exhaust air must not recirculate with intake air).
2. Cabinet interior must be open to allow for unrestricted exhaust air flow.
3. Ice transport tube needs minimum 1/4" per foot (2 cm per meter) pitch toward ice machine and should be secured to prevent dips and traps from forming.
4. Ducting must be provided if cabinet door does not mate directly to air intake gasket.
5. Cabinet interior must provide a minimum clear space of 23.50" (59.7 cm) high by 25.25" (64.1 cm) deep.
6. Grilles by others must meet minimum requirements for open air space shown above.
7. Utilities should be conveniently located as shown.

4 – Horizon Elite ice machine mounting accessories

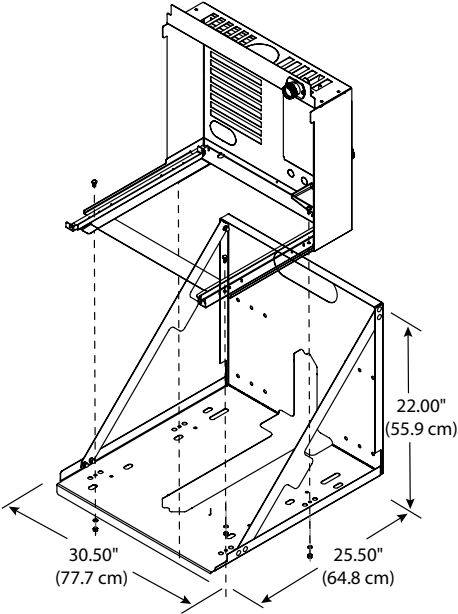
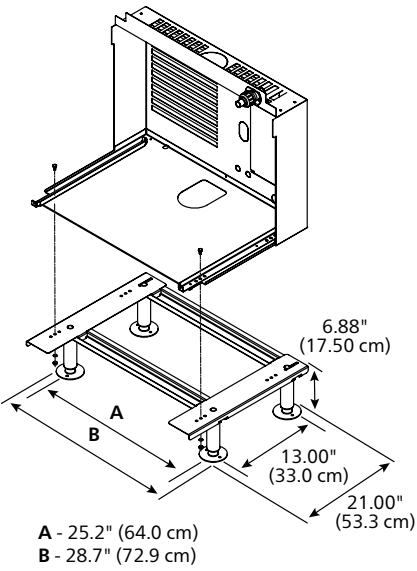
Optional wall mount bracket	Optional machine stand	Important specifier notes
 <p>30.50" (77.7 cm) 22.00" (55.9 cm) 25.50" (64.8 cm)</p>	 <p>6.88" (17.50 cm) 13.00" (33.0 cm) 21.00" (53.3 cm) A - 25.2" (64.0 cm) B - 28.7" (72.9 cm)</p>	<ol style="list-style-type: none"> For secure wall mounting, specify optional wall mount bracket. Wall and fasteners must support the weight of the ice machine, bracket, supply water and ice. Use of a backing board may be required with hollow wall construction. Machine stand mounting adds 6.88" (17.5 cm) to height of ice machine. No dips in tube routing allowed. Ice transport tube needs minimum 1/4" per foot (2 cm per meter) pitch toward ice machine and should be secured to prevent dips and traps from forming.

5 – Horizon Elite drains - specifier guidelines

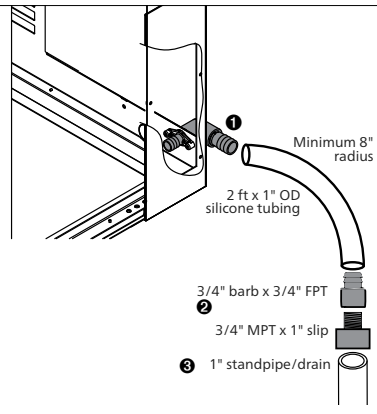
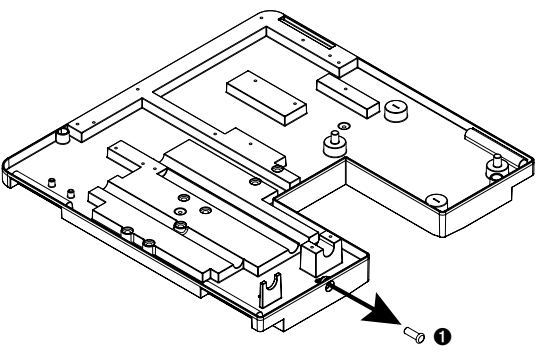
Ice machine drain plumbing	Important specifier notes: Where code allows, follow recommendation below.
 <p>2 ft x 1" OD silicone tubing Minimum 8" radius 3/4" barb x 3/4" FPT 3/4" MPT x 1" slip 1" standpipe/drain</p>	<ol style="list-style-type: none"> Apply Teflon tape to 3/4" male outlet ice machine fitting. Thread on either the provided straight 3/4" barb adaptor or a 90 degree adaptor. Connect the supplied 2' (0.61 m) silicone hose to the 3/4" drain barb ❶. It is recommended that the silicone hose be routed down into a 1.5" or 2" standpipe/drain. The minimum drain size for the ice machine is 1". Note: 3/4" to 1" PVC adapter fittings are provided if a larger drain size is not possible ❷ ❸. Note: Minimum 8" radius on silicone drain line. Drain line from the ice machine must have at least 1/4" per foot pitch (6.4 mm/0.3 m). Note: Standpipe/drain provided by others. All other components provided with ice machine.
Chassis drain plumbing – Required	Important specifier notes: Where code allows, follow recommendation below.
 <p>❶</p>	<ol style="list-style-type: none"> Remove white 3/8" plug from rear push-in fitting ❶. Route 3/8" OD drain tubing (preferably copper) through rear of docking station and fully insert into chassis base push-in fitting. Route into drain standpipe. Gravity drain. Ensure 3/8" OD tubing slopes down into drain standpipe without forming a trap.

6 – Horizon Elite ice tube runs - specifier guidelines

Long tube runs for RIDE remote ice delivery equipment

Labels in diagram: beverage dispenser, support straps, minimum of 6.00" (15.24 cm) turn/corner radius, ice transport tube – 1 3/16" OD, 2 1/8" OD with insulation, maximum 2' (60.9 cm), transport tube slope (toward ice machine) 1/4" (2 cm per meter) 1', wall-mounted ice machine.

Important specifier notes

- 75' (22.9 m) maximum ice transport tube run.
- Tubing routing bends must have a 6.00" (15.24 cm) radius or larger.
- Dips and traps are not allowed. A 3" (7.62 cm) or larger PVC pipe chase is suggested to support the tubing run. If not supported, secure insulated ice transport tube at least every 2' (0.61 m) to prevent drips and traps.
- Relative humidity levels above 80% in areas where the ice machine or ice transport tube is located may produce excessive condensation that will cause water damage.
- Contact factory for recommendations on running tubing through a decorative soffit or chase.

Ice production – Horizon Elite 1010 series, air-cooled models

Inlet water temperature F (C)	Ambient air temperature F (C)					lb (kg) production in 24 hr
	60 (16)	70 (21)	80 (27)	90 (32)	100 (38)	
50 (10)	1160 (526)	1061 (481)	962 (436)	825 (374)	688 (312)	
60 (16)	1093 (496)	1001 (454)	909 (412)	795 (361)	681 (309)	
70 (21)	1026 (465)	941 (427)	857 (389)	765 (347)	674 (306)	
80 (27)	971 (440)	893 (405)	815 (370)	730 (331)	644 (292)	
90 (32)	917 (416)	941 (427)	773 (350)	694 (315)	614 (279)	

Ice production – Horizon Elite 1410 series, air-cooled models

Inlet water temperature F (C)	Ambient air temperature F (C)					lb (kg) production in 24 hr
	60 (16)	70 (21)	80 (27)	90 (32)	100 (38)	
50 (10)	1593 (723)	1466 (665)	1339 (607)	1230 (558)	1121 (508)	
60 (16)	1518 (689)	1396 (633)	1275 (579)	1163 (528)	1052 (478)	
70 (21)	1442 (654)	1327 (602)	1211 (549)	1097 (498)	982 (446)	
80 (27)	1394 (632)	1272 (577)	1150 (522)	1050 (477)	950 (431)	
90 (32)	1345 (610)	1327 (602)	1089 (494)	1004 (456)	918 (417)	

Ice production – Horizon Elite 1010 series, water-cooled models

Potable water temperature F (C)	Condenser water temperature F (C)					lb (kg) production in 24 hr
	60 (16)	70 (21)	80 (27)	90 (32)	100 (38)	
50 (10)	1096 (498)	1043 (473)	1001 (454)	947 (430)	892 (405)	
60 (16)	1006 (457)	970 (440)	938 (426)	888 (403)	839 (381)	
70 (21)	917 (416)	898 (408)	874 (396)	830 (377)	786 (357)	
80 (27)	874 (397)	826 (375)	826 (375)	787 (357)	749 (340)	
90 (32)	831 (377)	778 (353)	778 (353)	745 (338)	712 (323)	

Ice production – Horizon Elite 1410 series, water-cooled models

Potable water temperature F (C)	Condenser water temperature F (C)					lb (kg) production in 24 hr
	60 (16)	70 (21)	80 (27)	90 (32)	100 (38)	
50 (10)	1436 (652)	1411 (641)	1385 (607)	1370 (622)	1354 (615)	
60 (16)	1417 (643)	1367 (633)	1318 (621)	1307 (593)	1296 (588)	
70 (21)	1397 (634)	1324 (602)	1251 (568)	1245 (565)	1238 (562)	
80 (27)	1318 (598)	1253 (577)	1189 (540)	1170 (531)	1151 (522)	
90 (32)	1238 (562)	1183 (602)	1127 (512)	1096 (497)	1064 (483)	

Agion is a registered trademark of Sciessent LLC.
 Open Kitchen is a trademark of Powerhouse Dynamics.
 HORIZON ELITE, ICE•DEVICE, ICE MANAGER, MICRO CHEWBLET, SAFECLEAN PLUS, SANISPONGE, SYMPHONY PLUS and VISION are trademarks of Follett Products, LLC.
 CHEWBLET, FOLLETT and RIDE are registered trademarks of Follett Products, LLC, registered in the US.
 Follett reserves the right to change specifications at any time without obligation. Certifications may vary depending on country of origin.

Self-contained 1010, 1410 series ice machine