

Vantage SL

SL1577

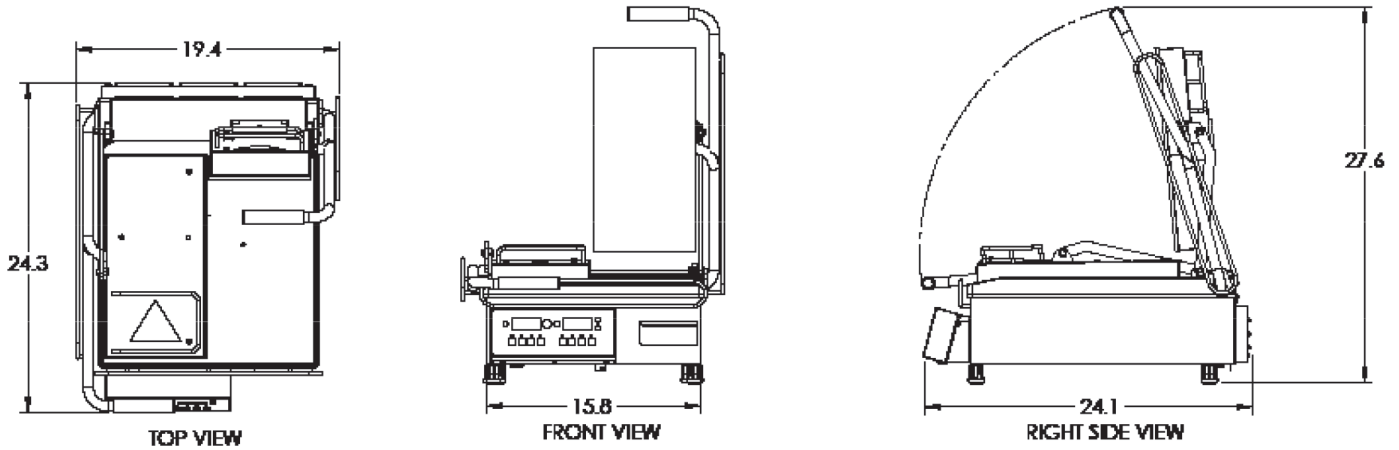

Equipment Details

Temperature Control	Yes	Shipping Weight	78lbs/35kg
Maximum Heat	525F/274C	Machine Weight	66lbs/30kg
Programmable Timer	Yes	Voltage	120/208/220
Thickness Control	Yes	Wattage	2200/2200/2800
ON/OFF Switch	Yes	Hertz	50/60
Controlled Heat Zones	3	Amps	18.3/10



PROLUXE™

CORPORATE HEADQUARTERS
20281 HARVILL AVE. PERRIS, CA 92570

HELPING COMMERCIAL KITCHENS
PRODUCE GREAT FOOD FASTER

ADVICE AND SUPPORT
1-800-624-6717

Grilling Perfection

This heavy-duty split lid grill is ideal for high-production kitchens looking to grill and seal sandwiches, burritos, quesadillas with ease. Our exclusive manufacturing process casts the heating elements into the platen resulting in more even heat distribution and longer life expectancy. Backed with an exclusive heating element limited lifetime warranty.



Vantage SL

Heavy-duty Split Lid Grill
SL1577



Double Your Output

Easily grill two separate menu items or double the output of a single entree.



HIGH PRODUCTION



EVEN HEAT DISTRIBUTION TECHNOLOGY



GRILL IN SECONDS



EMBEDDED HEATING ELEMENT LIFETIME LIMITED WARRANTY