



RF

Barrel Freezer & Ice Cream Freezer

4094 Paul Buchman Highway
Plant City, FL 33565
800.441.4014 | 813.870.0340
www.excellenceindustries.com

The company reserves the right to change the design and/or specifications of these products without notice. Printed in the USA.
Current version 09.22

KEY ASPECTS

SPECIAL FEATURES:

- Big impression in a small footprint
- Adjustable thermostat
- Casters standard
- Environmentally friendly hydrocarbon refrigerant

OPTIONS:

- Graphics



Complies with 2017 DOE standards for commercial freezer and ice cream freezer

Flip top accessible from any side



Divider: 4 sections



4 section divider top view

Cylinder shaped, looks great anywhere



With optional graphics

TECHNICAL SUMMARY

MODEL	SIZE				ELECTRICAL		REFRIGERATION		OTHER	
	Dimensions (inches)* Width x Depth x Height	Cubic Feet	Net Weight (lbs.)	Shipping Weight (lbs.)**	Voltage/Hz/Phase	Running Amps	Compressor HP	Refrigerant	Temperature	Container Quantity
RF-77HC	22 1/4 x 22 1/4 x 32 5/8	2.5	64	73	115/60/1	2.1	2/7	R-600a	-15°F to +5°F	238

*Dimensions are all nominal lengths

**Does not include weight of pallets when needed

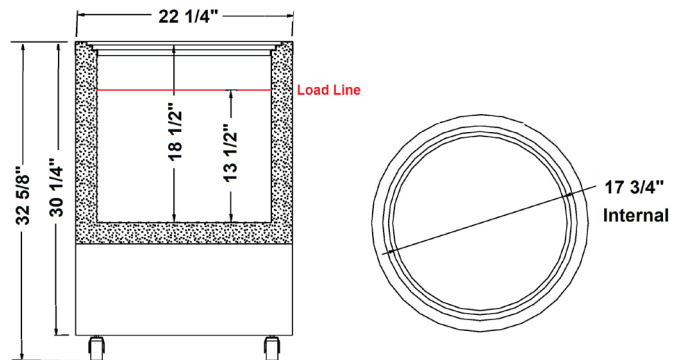

4094 Paul Buchman Highway
Plant City, FL 33565
800.441.4014 | 813.870.0340
www.excellenceindustries.com
ver. 09.22