

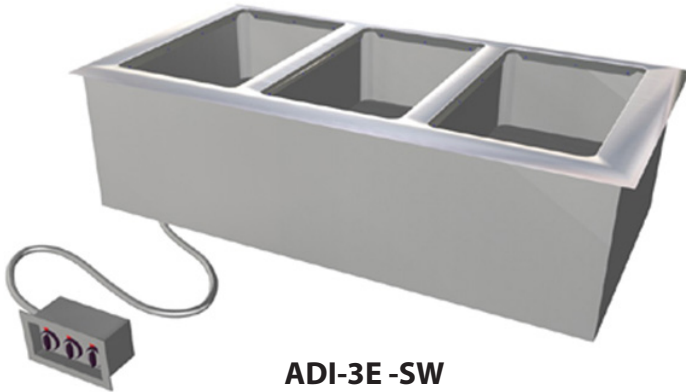

Your Solutions Partner

Specifications

F.O.B. Sedalia, Missouri 65301



ADI-3E-SW

OPTIONS:

- 3 phase wiring (except ADI-1E-SW)
- Individual valves
- Manifold drains
- Master valve
- Designer Foodshields
- Telescope covers
- Removable S/S carving station
- Adapter Plates
- Adapter Bars

Agency Listings:



DUKE MANUFACTURING CO.

2305 N. Broadway
 St. Louis, MO 63102
 800.735.3853 Toll Free
 314.231.5074 Fax
 www.dukemfg.com

SS-1127 Drop In Elec-Sealed Well

Approval Stamp(s):

PRODUCT INFORMATION:

PROJECT: _____

ITEM: _____

QUANTITY: _____

MODEL:

Drop-Ins - Hot Food Electric - Sealed Well

- ADI-1E-SW 18 1/4"L x 24 1/4"W x 12 3/4"H
- ADI-2E-SW 32 1/4"L x 24 1/4"W x 12 3/4"H
- ADI-3E-SW 46 1/4"L x 24 1/4"W x 12 3/4"H
- ADI-4E-SW 60 1/4"L x 24 1/4"W x 12 3/4"H
- ADI-5E-SW 74 1/4"L x 24 1/4"W x 12 3/4"H
- ADI-6E-SW 88 1/4"L x 24 1/4"W x 12 3/4"H

TOP RIM:

- Heavy gauge, 300 Series stainless steel
- Overhang on front, back and ends w/locking tabs
- Vinyl foam gasket as sealant
- Die-stamped openings - 12-1/16" x 20-1/16"

HEAT COMPARTMENTS:

- 6-1/4" deep stainless steel liner, wet or dry operation
- Sealed element in each compartment
 - 750 watt, 120 Volt/1 Ph
 - 900 watt, 208 Volt/1 Ph
 - 1200 watt, 240 Volt/1 Ph
- Individual open drains

CONTROL PANEL:

- Stainless steel face plate, plastic knobs
- Infinite switch controls in remote box
- 2 panels on units with 4, 5 or 6 wells
- UL approved

EXTERIOR HOUSING

- Heavy gauge paint grip steel

Specification subject to change



Drop-Ins - Hot Food Electric - Sealed Well

A.I.A. File No. 35-C-13

Catalog No. ADI-ELECHFSW

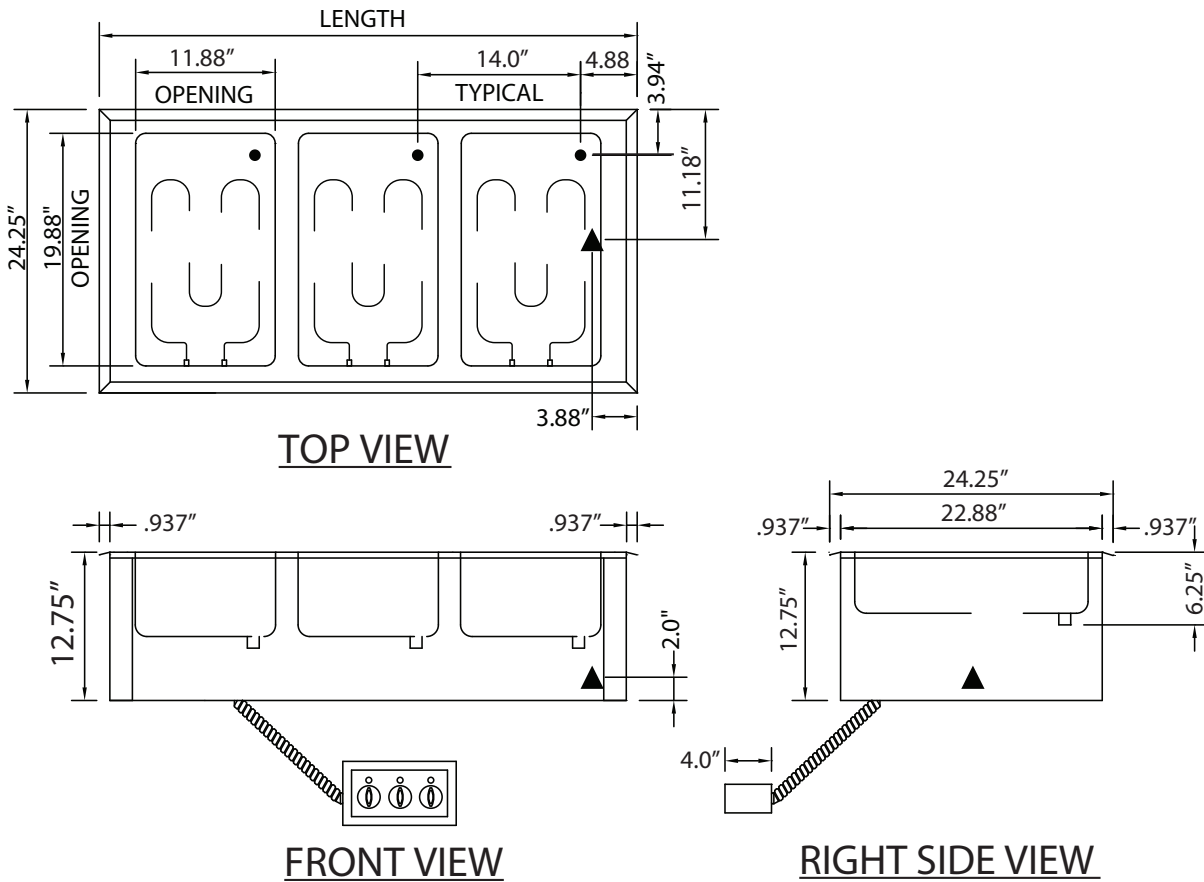

Dimensions:

Freight Class 100

Model	Length		Width		Height		Top Openings	Cutout Width		Cutout Length		Control Panels	Cube ft. Crated	Weight	
	in	cm	in	cm	in	cm		in	cm	in	cm			lbs	kg
ADI-1E-SW	18 1/4	46.4	24 1/4	61.6	12 3/4	32.4	1	23.125	58.74	17.25	43.82	1	8.2	43	19.6
ADI-2E-SW	32 1/4	81.9	24 1/4	61.6	12 3/4	32.4	2	23.125	58.74	31.25	79.375	1	13.0	75	34.1
ADI-3E-SW	46 1/4	117.5	24 1/4	61.6	12 3/4	32.4	3	23.125	58.74	45.25	114.94	1	17.7	90	40.9
ADI-4E-SW	60 1/4	153.0	24 1/4	61.6	12 3/4	32.4	4	23.125	58.74	59.25	150.50	2	22.5	115	52.3
ADI-5E-SW	74 1/4	188.6	24 1/4	61.6	12 3/4	32.4	5	23.125	58.74	73.25	186.06	2	27.2	140	63.6
ADI-6E-SW	88 1/4	224.2	24 1/4	61.6	12 3/4	32.4	6	23.125	58.74	87.25	221.62	2	32.0	220	100.0

REMOTE CONTROL CUTOUT IS 9" X 4-3/8"

Electrical Specifications:

(Consult factory for 3-phase electrical requirements and other options)

Model	120 Volt		208 Volt		240 Volt	
	watts	amps	watts	amps	watts	amps
ADI-1E-SW	750	6.3	900	4.3	1200	5.0
ADI-2E-SW	1500	12.5	1800	8.7	2400	10.0
ADI-3E-SW	2250	18.8	2700	13.0	3600	15.0
ADI-4E-SW	3000	25.0	3600	17.3	4800	20.0
ADI-5E-SW	3750	31.3	4500	21.6	6000	25.0
ADI-6E-SW	n/a	n/a	5400	26.0	7200	30.0



Duke Manufacturing Co.
2305 N. Broadway
St. Louis, MO 63102

Phone: 314-231-1130
Toll Free: 1-800-735-3853
Fax: 314-231-5074

www.dukemfg.com

DROP-IN - HOT FOOD - ELECTRIC - SEALED WELL