

"UBBB" MOBILE ICE CHEST

w/Insulated Basin

FEATURES:

- 10" Deep Ice Trough
- Insulated Basin
- 1/2" Raised Lip Around Top Of Ice Bin
- Includes Stainless Steel Sliding Lid

SPECIFICATIONS:

- Ice Bins Are TIG Welded, Exposed Welds Are Polished To Match Adjacent Surface
- Lid: 18GA Type 300 Stainless Steel
- Base: 18GA Type 300 Stainless Steel

CERTIFICATIONS:



UBBB-2460



UBBB-2460
(LID CLOSED)



5" LOCKING CASTERS



THREADED DRAIN TUBE

"UBBB" MOBILE ICE CHEST

MODEL	LENGTH (L)	DISTANCE TO CENTER (L ¹)	ICE CAPACITY (LBS)	WEIGHT (LBS)
UBBB-2436	36"	18"	219	100
UBBB-2448	48"	24"	296	127
UBBB-2460	60"	30"	373	155

ALL DIMENSIONS ARE TYPICAL. TOLERANCE +/- .500". JOHN BOOS & CO. RESERVES THE RIGHT TO CHANGE SPECIFICATIONS WITHOUT NOTICE.

DETAILED SPECIFICATIONS

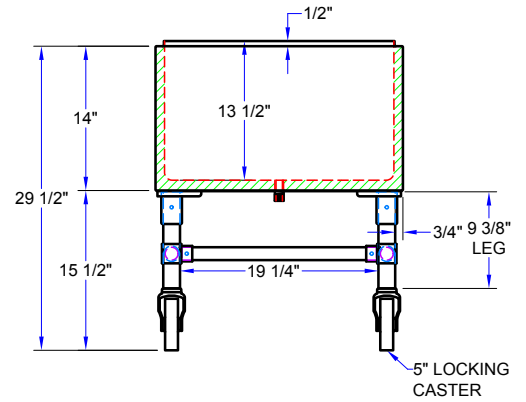
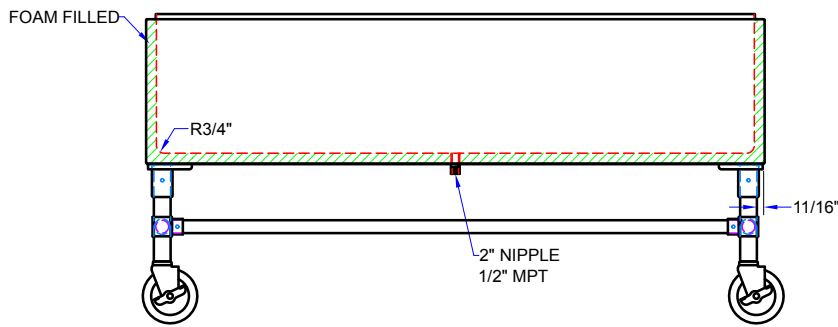
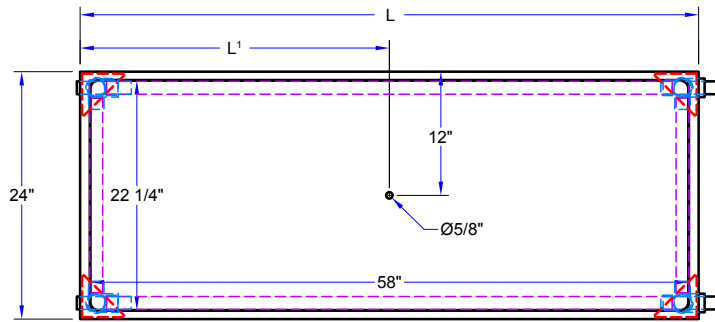

"UBBB" MOBILE ICE CHEST

MODEL	LENGTH (L)	DISTANCE TO CENTER (L')	ICE CAPACITY (LBS)	WEIGHT (LBS)
UBBB-2436	36"	18"	219	100
UBBB-2448	48"	24"	296	127
UBBB-2460	60"	30"	373	155

ALL DIMENSIONS ARE TYPICAL. TOLERANCE +/- .500". JOHN BOOS & CO. RESERVES THE RIGHT TO CHANGE SPECIFICATIONS WITHOUT NOTICE.