



PROJECT: _____
 ITEM # _____ QTY: _____
 MODEL # _____
 AIA # _____ SIS # _____

PIZZA PREP TABLE WITH DRAWERS

PIZZA PREP TABLE WITH DRAWERS

VPPD67HC-4



EXCLUSIVE WARRANTY

- ▶ 7 Year Parts, Labor and Compressor
- ▶ Exclusive 2 Year Warranty On Magnetic Door Gaskets
- ▶ Lifetime Warranty On Handles & Hinges (parts only)



CABINET CONSTRUCTION

- Stainless Steel Exterior (galvanized back and bottom)
- Aluminum Interior
- Hinged, Insulated, Removable Flat Lift-Up Lid
- One-Piece, Snap-In Magnetic Drawer Gaskets
- Heavy-Duty Aluminum Pan Liner
- 8' Cord And Plug (see electrical data for details)

REFRIGERATION

- Refrigeration System Uses R-290 Refrigerant To Comply With All Environmental Concerns
- Side Mounted Refrigeration System For Serviceability
- Adaptive Defrost For Reduced Energy Consumption And More Consistent Product Temperatures
- Epoxy Coated Evaporator Coil
- Refrigerator Capable Of Maintaining Product Temperature 36°F To 38°F

FEATURES

- Full Electronic Control
- Low Profile Horizontal Drawer Handles
- Stay-Open Drawer Feature For Easy Product Loading
- Heavy-Duty Stainless Steel Drawer Frames
- Heavy-Duty Pan Divider Supports Supplied
- Locking Divider Bars (drawers only)
- Top Accommodates 6" Deep Food Service Pans (pans not included)
- Accommodates 6" Deep Full Size Food Service Pans In Both Upper And Lower Drawers (pans not included)
- Heavy-Duty, Telescoping Drawer Slides With Locking Mechanism
- 275 lbs Drawer Load Rating (per drawer)
- Removable 19" Wide Cutting Board
- 3" Casters Two With Locks



Please Verify Qualifying Units By Visiting:
www.energystar.gov/cfs

OPTIONS & ACCESSORIES

- Stainless Steel Interior
- Stainless Steel Back
- Compressor On Left (specify at time of order)
- Drawer Locks
- Single & Double Overshelf Kit
- 6" Casters, 6" Legs Or 6" Seismic Legs
- Remote Models* (6" legs only)
 (refrigerant must be specified at time of order, see note on back on page)

3779 Champion Blvd, Winston-Salem, NC 27105

ph: (888) 845-9800 | fax: (800) 253-5168

Sales@VictoryRefrigeration.com | VictoryRefrigeration.com

Rev. 7/1/24 Printed in U.S.A.

APPROVAL: _____ DATE: _____

VICTORY PIZZA PREP TABLE WITH DRAWERS

VPPD67HC-4

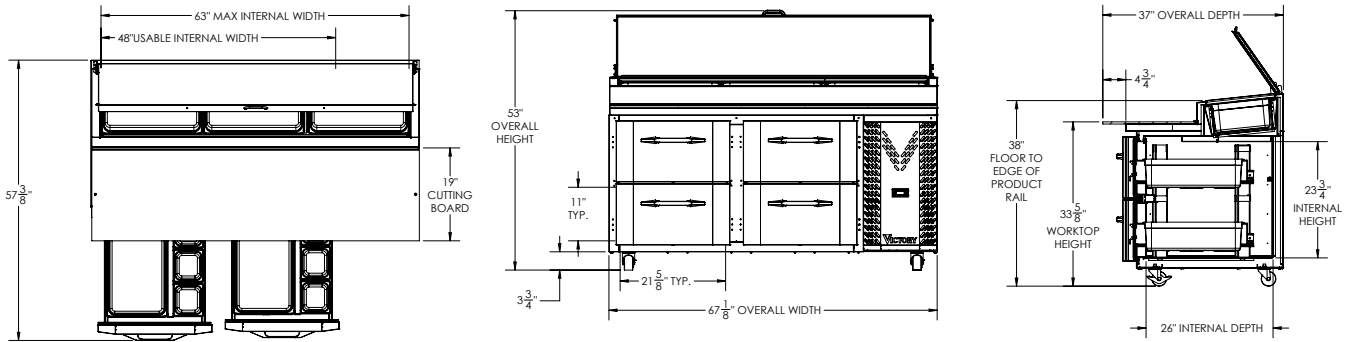

We reserve the right to change specifications and product design without notice. Such revisions do not entitle the buyer to corresponding changes, improvements, additions or replacements for previously purchased equipment. Dimensional tolerances +/- 1/4". Metric dimensions (MM)

2" Bottom & 2" Rear clearance is required

CHARACTERISTICS		ELECTRICAL DATA		SHIPPING DETAILS	
Net Capacity (cubic ft.)	20.68	Cabinet Voltage	115/60/1	Height	49"
Width, Overall (in.)	67 1/8"	Total Amperes	4.5	Width	70"
Depth, Overall (with cutting board)	37"	NEMA Plug (8' cord)	5-15P	Depth	45"
Height Overall (with casters)	53"	REFRIGERATION DATA		Crated Weight	584 lbs
Depth, Drawer Extended	57 3/8"	Condensing Unit Size, HP	1/2	*NOTE: Remote units are field wired and come with 6" legs. Refrigerant must be specified at time of order.	
Drawer Openings (in.)	21 5/8" x 11"	Refrigerant	R-290		
No. Of Drawers	4	Capacity (BTU/HR) (100°F/20°F)	2940		
		Heat Rejection (BTU/HR)	4410		
		Charge (lbs/grams/ounces)	0.231 / 105 / 3.70		

3779 Champion Blvd, Winston-Salem, NC 27105 | ph: (888) 845-9800 | fax: (800) 253-5168

Sales@VictoryRefrigeration.com | VictoryRefrigeration.com

Rev. 7/1/24 Printed in U.S.A.