

3M™ Water Filtration Products

SPEC# _____

QUANTITY _____

application: **COFFEE/ESPRESSO/STEAMERS/ICE/COLD BEV**

models:

ScaleGard™ HP Reverse Osmosis System



The ScaleGard™ HP reverse osmosis system produces 750 to 938¹ gallons of Recipe Quality Water™ per day for a better tasting cup of coffee, espresso or cold beverage. Equipped with a precision blending valve, this wall-mountable system allows a store owner to dial in the desired level of dissolved-minerals for the perfect cup of coffee, espresso or cold beverage.

The system also incorporates a “smart” diagnostic monitoring system that alerts the operator when the ScaleGard™ HP system requires maintenance. This feature helps to ensure that the system is performing properly.

The ScaleGard™ HP incorporates a modular design that allows the system to grow with business needs. Simply add RO and Pre-Filter expansion heads to double the RO water production.

PRODUCT BENEFITS

- Can easily double RO production by adding RO and Pre-Filter expansion heads (Sold Separately)
- Pre-Filter cartridge contains Integrated Membrane Pre-Activated Carbon Technology (“I.M.P.A.C.T.”) media which includes Chlorine/Chloramines protection to reduce corrosion and protects the RO membrane
- Alerts the operator when the system requires maintenance
- Allows store owner to dial in the desired level of dissolved minerals for Recipe Quality Water™
- Base system produces 750-938 gpd¹ (0.52-0.65 gpm) of RO water
- The integrated heavy duty booster pump provides long pump life, helps reduce maintenance cost, and runs quietly
- Real-time pressure and TDS monitoring
- Permeate rinse for added TDS reduction and control
- Allows for small footprint and easy installation
- High RO efficiency capacity of up to 80% (with blending) which allows for high water savings
- Sanitary Quick Change (SQC) cartridge design allows for quick cartridge change-outs
- Available in 110/60Hz and 220V/50Hz

PRODUCT SPECIFICATIONS

Model Number	Description	Part Number	Reduction Claims	Capacity
ScaleGard™ HP Reverse Osmosis System	High Flow Reverse Osmosis System	5629101 ²	—	750-938 gpd 2,839-3,551 liters
		6239301 ³		N/A
		6239302 ⁴		N/A
HFRO-500	High Flow Reverse Osmosis Membrane	5626903	N/A	—
HF90-CL-RO	Pre-Filter*	5613529	0.2 micron, bacteria ⁵ , sediment, chlorine taste and odor, chloramines	—
ScaleGard™ HP Reverse Osmosis System Installation Kit	Installation Kit (Sold Separately)	6841441	—	—

* For more pre-filter and tank options, please refer to the Foodservice Price Book
 1. Production rate is dependent on water temperature and blending valve setting.
 2. Scalegard HP reverse osmosis system (110V) with Pre-Filter and RO cartridges.
 3. Scalegard HP reverse osmosis system (110V) without Pre-Filter and RO cartridges.
 4. Scalegard HP reverse osmosis system (220V) without Pre-Filter and RO cartridges.
 5. As tested and verified with *e.Coli* ATCC (11229) or *Pseudomonas* (B) *diminuta* ATCC (19146) by manufacturer's laboratory.



ScaleGard™ HP Reverse Osmosis System

3M™ Water Filtration Products

SPEC# _____
 QUANTITY _____
 MODEL NUMBER _____
 PART NUMBER _____

IMPORTANT: INSTALLATION TIPS

These installation tips are for informational purposes only and are not intended to be used as actual installation instructions.

- Maximum Inlet Water TDS of <1000 ppm
- Maximum Inlet Water Hardness of <10 grains
- Maximum Total Chlorine Concentration <0.1 ppm or mg/l

⚠ WARNING: To reduce the risk associated with the ingestion of contaminants:

- Do not use with water that is microbiologically unsafe or of unknown quality without adequate disinfection before or after the system.

CAUTION: To reduce the risk associated with property damage due to water leakage:

- Read and follow Use Instructions before installation and use of this system.
- The RO cartridge **MUST** be replaced every twenty four (24) months, or sooner if a noticeable increase in TDS occurs.
- The disposable filter cartridges **MUST** be replaced every six (6) months, at the rated capacity or sooner if a noticeable reduction in flow rate occurs.

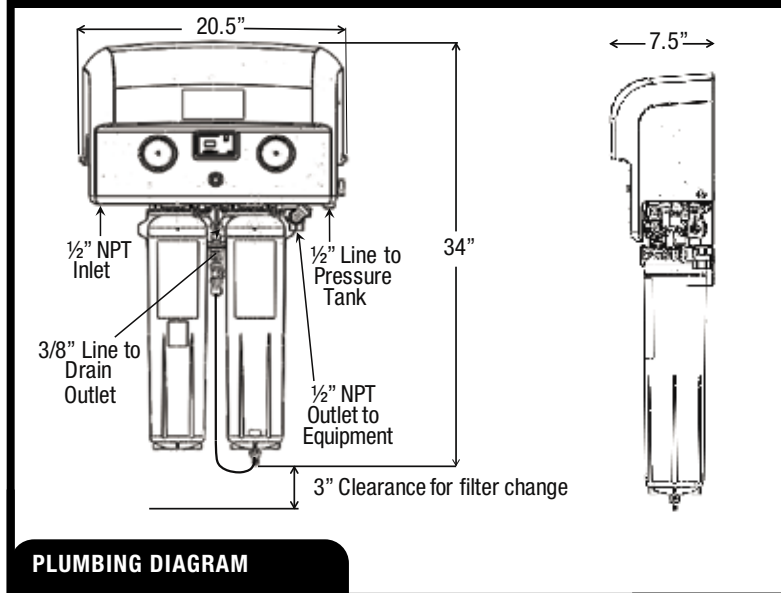

PLUMBING DIAGRAM

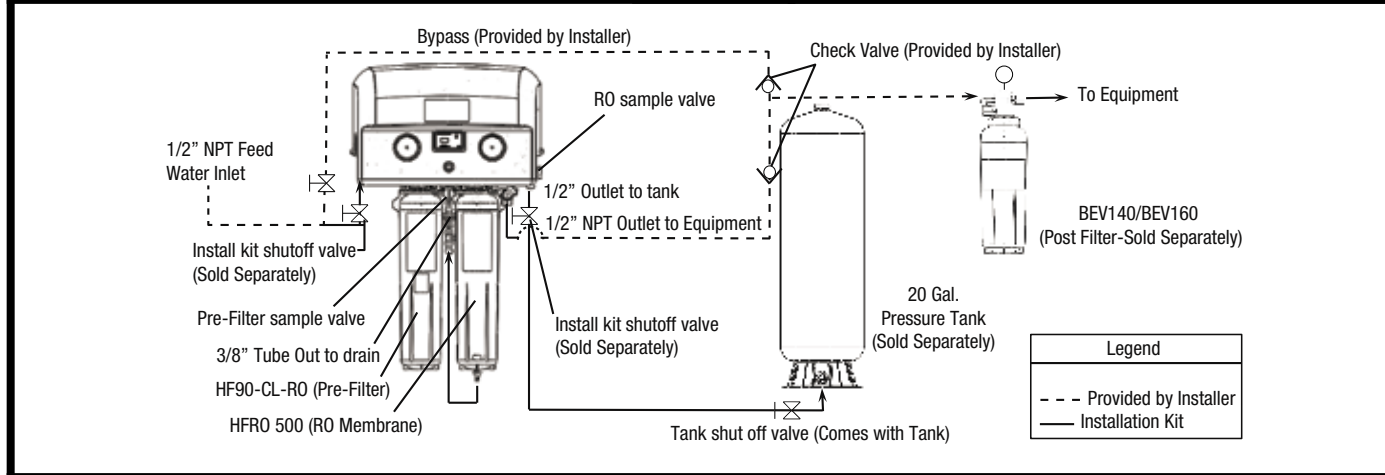

Diagram is for quick reference only. Installation must be performed in accordance with the Installation and Use Manual accompanying the product.

3M Purification Inc. (3M Purification) recommends regularly scheduled maintenance and replacement of the filter cartridge(s) in order for the product to perform as advertised/sold. 3M Purification shall not be liable for system failures due to improper maintenance.

LIMITED WARRANTY

3M Purification Inc. warrants this Product (excluding filter cartridge or filter membrane) will be free from defects in material and manufacture for the period of one (1) year from the date of purchase. The filter cartridge or RO membrane is warranted to be free from defects in material and manufacture for one (1) year. This warranty does not cover failures resulting from abuse, misuse, alteration or damage not caused by 3M Purification Inc. or failure to follow installation and use instructions. No warranty is given as to the service life of any filter cartridge or membrane as it will vary with local water conditions and water consumption. **3M PURIFICATION INC. MAKES NO OTHER WARRANTIES OR CONDITIONS, EXPRESS OR IMPLIED, INCLUDING, BUT NOT LIMITED TO, ANY IMPLIED WARRANTY OR CONDITION OF MERCHANTABILITY OR FITNESS FOR A PARTICULAR PURPOSE OR ANY IMPLIED WARRANTY OR CONDITION ARISING OUT OF A COURSE OF DEALING, CUSTOMER OR USAGE OF TRADE.** If the Product fails to satisfy this Limited Warranty during the warranty period, 3M Purification Inc. will (at its discretion) replace the Product or refund your Product purchase price. This warranty does not cover labor. **The remedy stated in this paragraph is Customer's sole remedy and 3M Purification Inc.'s exclusive obligation. For additional information, see the entire Limited Warranty located in the product Installation and Operating Instruction Manual.**

Limitation of Liability. 3M Purification Inc. will not be liable for any loss or damage arising from this 3M Purification Inc. product, whether direct, indirect, special, incidental, or consequential, regardless of the legal theory asserted, including warranty, contract, negligence or strict liability. Some states and countries do not allow the exclusion or limitation of incidental or consequential damages, so the above limitation or exclusion may not apply to you.



3M Purification Inc.
 400 Research Parkway
 Meriden, CT 06450 U.S.A.
 Phone: 1.866.990.9785
 Worldwide: 203.237.5541
 Fax: 203.238.8701
 www.3Mfoodservice.com
 www.3Mpurification.com

3M is a trademark of 3M Company.
 ScaleGard is a trademark of 3M Company used under license.
 © 2012 3M Company. All rights reserved.
 70020299593 REV 1012