



BEVERAGE-AIR

Project: _____	AIA#
Item: _____	
Location: _____	SIS#
Approved: _____	

ST34HC DUAL ACCESS, COLD WALL: SCHOOL MILK SERIES

SCHOOL MILK COLD WALL COOLER

ST34HC Dual Access Cooler

Hydrocarbon Series

MODEL:
ST34HC-W-02



7 Year Parts/Labor Warranty
7 Year Compressor Warranty

CABINET CONSTRUCTION

- White coated steel exterior
- Stainless steel interior
- Stainless steel lids, hinged doors and door latches
- Dual sided access
- Full electronic control
- Heavy-duty epoxy coated steel wire floor racks standard
- Floor drain is centrally located for easy cleaning and connecting to drain hose with hose adapter
- Flexible compression door gaskets, ensures a tight seal
- Self-latching doors/lids with safety bumpers
- Exterior thermometer
- Cylinder locks
- 4" Heavy-duty plate casters (2 with locks)
- Cold wall milk coolers are designed to hold product temperature during service. Product should be removed at the end of service and moved to long-term, refrigerated storage

OPTIONS & ACCESSORIES

- Corner bumpers
- Cafeteria tray slides
- Graphics

REFRIGERATION SYSTEM

- Uses environmentally friendly, energy efficient R290 refrigerant, and meets all regulatory requirements for CARB, SNAP, DOE & more
- Maintains product temperature between 36°F- 40°F



Please verify qualifying units by visiting:
www.energystar.gov/cfs

3779 Champion Blvd., Winston-Salem, NC 27105
1-888-845-9800 Fax: 1-336-245-6453
Beverage-Air.com Sales@bevair.com



BEVERAGE-AIR

School Milk Cooler - Dual Access

Model: ST34HC-W-02

MODEL	ST34HC-W-02
EXTERNAL DIMENSIONAL DATA	
Width Overall	34"
Depth Overall	31 ¼"
Height Overall with Casters	41 ⅞"
Number of Lids/Doors	Dual Access
Both Lids Extended	61"
INTERNAL DIMENSIONAL DATA	
NET Capacity (cubic ft.)	12.37
Internal Width Overall (in)	31"
Internal Depth Overall (in)	27"
Internal Height Overall (in)	25 ½"
CASE CAPACITY	
13" X 13" X 11"	8
19" X 13" X 11"	4
ELECTRICAL DATA	
Full Load Amperes	3.7
REFRIGERATION DATA	
Horsepower	1/2
Capacity (BTU/Hr)	1690
Heat Rejection (BTU/Hr)	2535
Charge (lbs/grams/ounces)	0.1544 / 70 / 2.5
SHIPPING DATA	
Gross Weight - Crated	290 lbs
Height - Crated	44"
Width - Crated	37"
Depth - Crated	33"

We reserve the right to change specifications and product design without notice. Such revisions do not entitle the buyer to corresponding changes, improvements, additions or replacements for previously purchased equipment. Dimensional tolerances +/- 1/4". Metric dimensions (MM).

Model Views

Required Clearance: 4 ¾" bottom

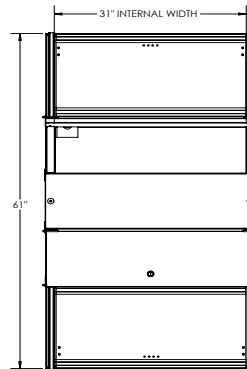

PLAN VIEW

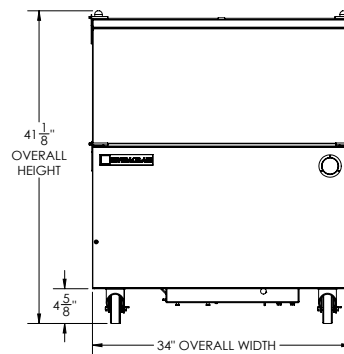

ELEVATION VIEW

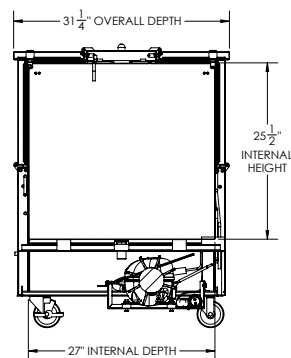

SIDE VIEW

ELECTRICAL CONNECTION



115/60/1
NEMA 5-15P

Unit pre-wired at factory and include 8' long cord and plug set.

