

Special Features:

- ✓ Heated Holding / Proofing Cabinet
- ✓ Full Height Model
- ✓ Sturdy Aluminum Construction
- ✓ Exterior Color: Silver
- ✓ (36) 18" x 26" pan capacity
- ✓ Manual Heat and Humidity Controls
- ✓ Single Door, Single Section Unit
- ✓ Clear Door Allow Operators to See Cabinet Contents
- ✓ Easy to Use Lip Load Slides Hold Pans Securely
- ✓ Power type: Electric
- ✓ Plug Type: NEMA 5-15P
- ✓ Stands on (4) 5" Casters, Front 2 Casters Lock to Prevent Unintentional Movement
- ✓ Certifications: NSF & UL Listed

Product Description:

The Empura E-HP1836 is a full height holding / proofing cabinet with a sturdy and elegant aluminum construction, (36) 18" x 26" pan capacity, and manual temperature controls. This holding / proofing cabinet features lip load slides that hold pans securely and the clear door allows the operator to view the contents. This model stands on 5" casters, the front two of which have locks to help prevent unintentional movement and keep the unit steady.

About Empura Holding / Proofing Cabinets:

Empura Holding / Proofing Cabinets are an economical choice when you are looking to update or expand your kitchen's heated holding and dough proofing capacity. Sturdy aluminum construction and high pan capacities make these cabinets a dependable option for business owners. You can count on the Empura Holding / Proofing Cabinets to proof dough perfectly and keep your product at the proper temperature for safe serving.

Intended For Commercial Use Only. Empura assumes no liability for component failure, factory defects or any other damages for units installed in non-commercial foodservice or residential applications.



TECHNICAL SPECS

Dimensions & Construction

| | |
|------------------------|-------------------|
| Overall Width | 23-1/8" |
| Overall Depth | 33-3/16" |
| Overall Height | 66-1/2" |
| 18" x 26" Pan Capacity | 36 Pans |
| Cabinet Size | Full Size |
| Construction Material | Aluminum |
| Number of Doors | 1 |
| Door Type | Clear |
| Dutch Half Door | No |
| Insulation | No |
| Casters | 5" (Front 2 Lock) |
| Sections | 1 |
| Interior Configuration | Lip Load Slides |

Heating & Electrical

| | |
|-------------------|--------------|
| Power Type | Electric |
| Control Type | Manual |
| Temperature Range | 80°F - 185°F |
| Plug Type | NEMA 5-15P |
| Amps | 12 |
| Hertz | 60 |
| Phase | 1 |
| Voltage | 120 |
| Wattage | 1,440 |
| Humidity Control | Yes |

UNIT VIEW

Front Angled View

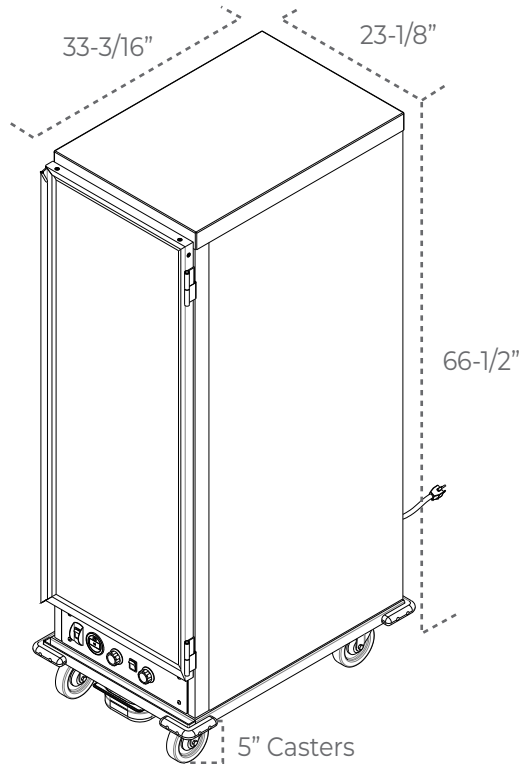

Attention CA Residents: This product can expose you to chemicals including lead, which are known to the State of California to cause cancer, birth defects, or other reproductive harm. For more information, go to www.p65warnings.ca.gov.



NEMA 5-15P Plug:
This unit comes with a NEMA 5-15P plug