

# TITAN STAINLESS

## CUSTOM FOODSERVICE FABRICATION

502 Usher Street · Pageland, SC · 704-243-8717 · [www.titan-stainless.com](http://www.titan-stainless.com)



### SOILED DISHTABLE WITH LANDING LEDGE – LEFT SIDE OF MACHINE

TITAN STAINLESS Dishtables are made using all-welded heavy gauge stainless steel construction. Assembly is not required; however, equipment can be disassembled for convenience. The backs of the tables are formed into a 9" tall x 2" thick backsplash with angled top; front and side edges feature our standard 3"H raised rolled edge. Dishmachine opening is 20-3/4" standard. Landing ledge tables are provided with a 6"W ledge which steps up 1/2" to prevent water runoff. A 20" x 20" x 8" pre-rinse sink bowl is provided along with 8" O.C. faucet holes in the backsplash (plumbing components are not provided). Reinforcing channels are applied to the underside of the top and sealed with double-sided sound dampening tape. 1-5/8" diameter tubing is fitted into stainless steel leg sockets, which are welded to reinforcement below, preventing surface imperfections. Legs are removable, and furnished with adjustable stainless steel bullet feet. 1-5/8" diameter cross-rails are welded to the table legs. All welds are ground and polished to a smooth finish.

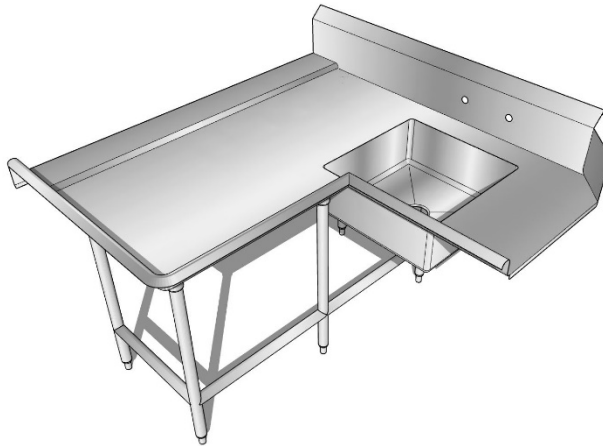

### MODEL NUMBER SELECTION / INFORMATION

(Example #: 5SDT-L-LS)

Dishtables with landing ledges are available in standard lengths from 4'-0" to 10'-0", in 1-foot increments, at the *dishmachine* side of the table—the other length of the table is 60" standard. Standard width is 30" to accommodate standard commercial dishmachines (with an additional 6" of width at the landing ledge). Additional legs may be added as required, as dictated by the length.

- See **AutoQuotes™** for full list of model numbers and pricing, along with all additional accessories
- Custom sizes and configurations are available upon request

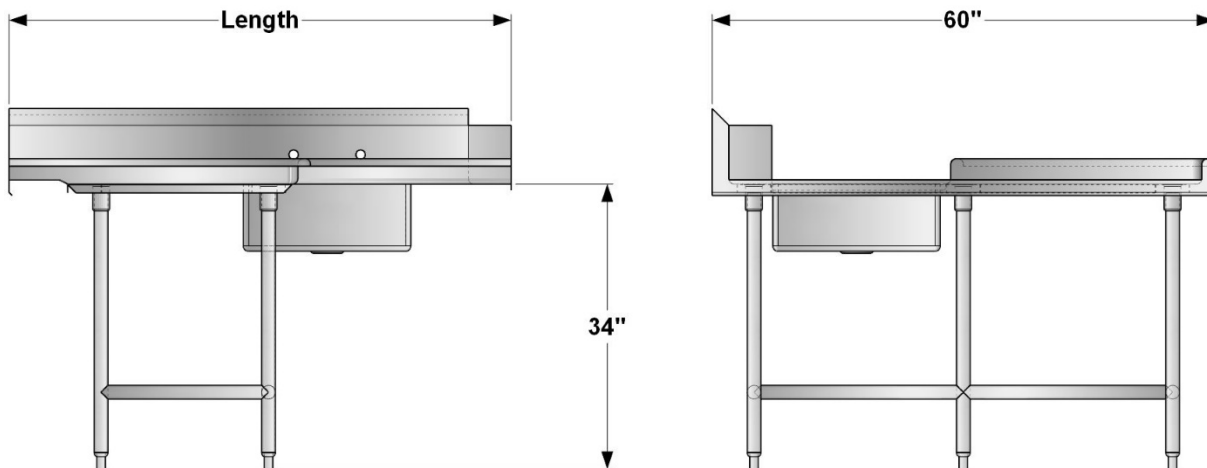

**TITAN STAINLESS**

502 Usher Street · PO Box 8 · Pageland, SC 29728  
Contact: 704-243-8717 · [quotes@titan-stainless.com](mailto:quotes@titan-stainless.com) · [www.titan-stainless.com](http://www.titan-stainless.com)

