

MADE IN ITALY



Models:

220E / 250E / 300E / 350E

Standard Features

- Anodized Aluminum with Corrosion Resistance
- Base is one solid piece with no crevices – prevents bacterial growth and build-up
- Adjustment Knob for a variety of Slice Cuts
- Built-in Sharpener for a consistently sharp edge
- Double Ball Bearing Sliding Carriage
- Belt Transmission



1-year parts and labor warranty (US Only)

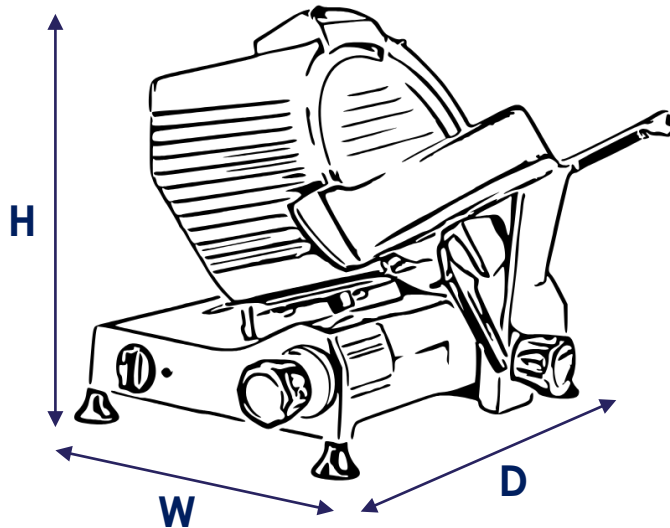

Sharpening Stones



RFAC135

RFAC134

SPECIFICATIONS				
	220E	250E	300E	350I
Cut Thickness	0 to 19/32" (0 - 15.1 mm)	0 to 5/32" (0 - 3.97 mm)	0 to 5/8" (0 - 15.9 mm)	0 to 5/8" (0 - 15.9 mm)
Blade	9"	10"	12"	14"
Slicing Capacity	7.5" x 6.3" (190.5 x 160.0 mm)	8.7" x 7.5" (221 x 190.5 mm)	8.6" x 8.6" (218.4 x 218.4 mm)	12.2" x 10.2" (309.9 x 259.1 mm)
Motor Power (Hp)	1/4	1/3	3/8	1/2
Power Supply	110V/60hz/1ph			
Amps	1.9	2.2	2.6	3.7
Plug / Connection	Nema 15-5P			
External Dim WxDxH	22.8" x 15.9" x 13.4" (580 x 405 x 340 mm)	24.4" x 16.7" x 14.6" (620 x 425 x 370 mm)	25.6" x 19.5" x 17.3" (650 x 495 x 440 mm)	35.0" x 23.0" x 18.9" (890 x 585 x 480 mm)
Weight (lbs)	30	35	51	80
Packed Unit Dim WxDxH	22" x 20" x 19"	25" x 21" x 20"	24" x 21" x 20"	28" x 31" x 22"
Packed Unit Weight (lbs)	33	40	55	97



Notes:

- Properly clean and dry after daily use to ensure best performance and equipment longevity.
- For proper use and optimum durability of moving parts, adequate lubrication must be maintained – RSPM040 Lubricant



Nema 5-15 125 VAC
2 Pole, 3 Wire
Grounding

AMPTO is continuously improving products. Specifications are subject to change without notice.