



Special Features:

- ✓ 47 cu. ft. storage capacity
- ✓ (2) solid swing doors with self-closing and 90° stay-open feature
- ✓ Locks & keys included for security
- ✓ 33°F–41°F temperature range
- ✓ 1/2 HP bottom-mounted compressor
- ✓ Eco-friendly CFC-free R290 refrigerant
- ✓ (6) heavy-duty adjustable PVC-coated shelves
- ✓ Heavy-duty 4" casters with brakes (included)
- ✓ Durable stainless steel construction
- ✓ Freestanding installation
- ✓ 115V / 6.2 amps / NEMA 5-15P plug
- ✓ ETL & ETL-Sanitation certified, meets NSF-7 standards
- ✓ ENERGY STAR® certified for efficiency

Product Description:

The Empura 47 cu. ft. reach-in refrigerator delivers dependable, energy-efficient performance for commercial kitchens. Its stainless steel build, self-closing doors with a 90° stay-open feature, and six adjustable shelves offer durability and convenience. A bottom-mounted 1/2 HP compressor maintains 33°F–41°F using eco-friendly R290 refrigerant, supported by precise electronic controls. With locking doors, heavy-duty 4" casters, and ETL certification, this ENERGY STAR® unit is tested and conforms to NSF-7 standards, offering reliable & efficient refrigeration.

Intended For Commercial Use Only. Empura assumes no liability for component failure, factory defects or any other damages for units installed in non-commercial foodservice or residential applications.

About Empura Reach-In Refrigerators:

Empura reach-in refrigerators are built for the demands of commercial kitchens, featuring durable stainless steel construction and efficient, consistent cooling. Most models include solid swing doors with self-closing and stay-open functions, along with adjustable shelves for flexible storage. Using bottom-mounted compressors and eco-friendly refrigerants, they deliver reliable temperature control with strong energy efficiency. Empura units are tested and conform to NSF-7 standards & are ETL certified, providing dependable, professional-grade refrigeration.



TECHNICAL SPECS

Dimensions

Overall Width	54"
Overall Depth	32.2"
Overall Height	82.5"
Storage Capacity	47 Cu. Ft.
Casters	4
Caster Height	4"

Refrigeration

Refrigerant	R290
Temperature Range	33-41 °F
Compressor Horsepower	1/2 HP
CFC Free	Yes
BTU (LBP)	N/A
Compressor Location	Bottom Mounted

Construction

Display / Control Type	LED Display / Digital
Exterior Materials	430 Stainless Steel
Interior Materials	Sides 201 Stainless, Floor 304 Stainless
Shelves	PVC Coated
Number of Doors	2
Door Type	Solid
Door Hinge Location	Right, Left
Number of Shelves	6
Installation	Freestanding

Electrical

V / HZ / Phase	115v/60hz/1ph
Amps	6.2
Plug Type	NEMA 5-15P

Shipping

Ship Weight	450 lbs.
-------------	----------

UNIT VIEW

Front View

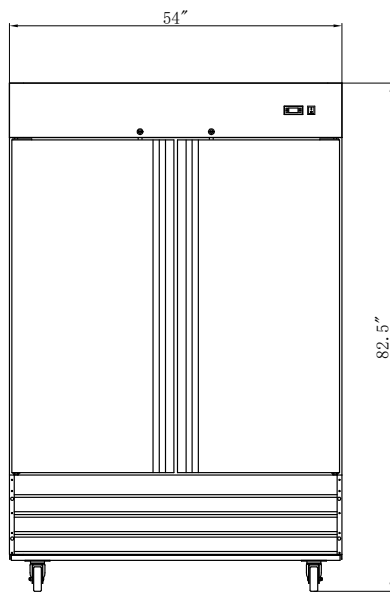

Side View

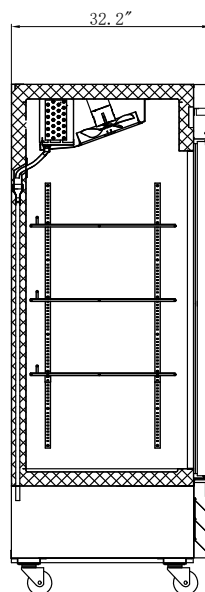

Top View

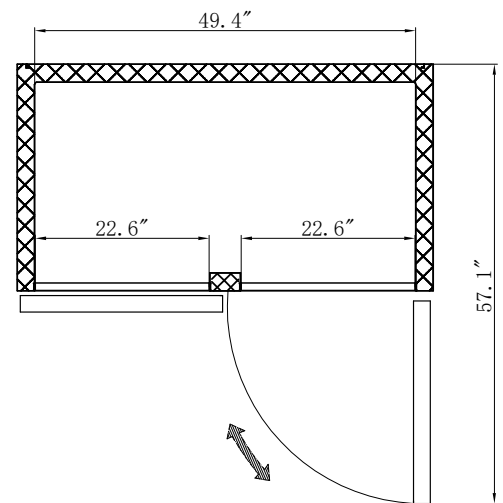

Attention CA Residents: This product can expose you to chemicals including lead, which are known to the State of California to cause cancer, birth defects, or other reproductive harm. For more information, go to www.p65warnings.ca.gov



NEMA 5-15P Plug:
This unit comes with a NEMA 5-15P plug