

# "SUS" DRY STORAGE SHELF

## 18GA Stainless Steel Shelves

**FEATURES:**

- 18GA Type 400 Stainless Steel Shelves With #4 Polish
- 1-1/2" Stallion Edge On All Sides Of Shelf
- For General Purpose Dry Storage Or In Refrigerators And Freezers
- Solid Surface Shelf For Easy Clean-Up Of Spills
- Adjustable Bullet Feet
- Optional 5" Locking Casters
- Shipped Knocked Down, Easy To Assemble

**SPECIFICATIONS:**

- Stainless Steel Shelves Are TIG Welded, Exposed Welds Are Polished To Match Adjacent Surface
- Knock Down Design With Adjustable Shelves
- Shelf: 18GA Type 400 Stainless Steel
- Legs: 1-5/8" Round O.D. 16GA Tubular Stainless Steel
- Gussets: Stainless Steel
- Feet: 1" Adjustable Stainless Steel Bullet Feet



SUS-244272-4

### "SUS" DRY STORAGE SHELVES

MODEL	SHELF SIZE (L X W)	OVERALL SIZE (L X W X H)	# OF SHELVES	WEIGHT (LBS)
SUS-183036-2	30"X18"	32"x20"x36"	2	32
SUS-184236-2	42"X18"	44"x20"x36"	2	37
SUS-185436-2	54"X18"	56"x20"x36"	2	45
SUS-243036-2	30"X24"	32"x26"x36"	2	36
SUS-244236-2	42"X24"	44"x26"x36"	2	48
SUS-245436-2	54"X24"	56"x26"x36"	2	57
SUS-183060-3	30"X18"	32"x20"x60"	3	47
SUS-184260-3	42"X18"	44"x20"x60"	3	55
SUS-185460-3	54"X18"	56"x20"x60"	3	67
SUS-243060-3	30"X24"	32"x26"x60"	3	54
SUS-244260-3	42"X24"	44"x26"x60"	3	72
SUS-245460-3	54"X24"	56"x26"x60"	3	85
SUS-183072-4	30"X18"	32"x20"x72"	4	61
SUS-184272-4	42"X18"	44"x20"x72"	4	72
SUS-185472-4	54"X18"	56"x20"x72"	4	88
SUS-243072-4	30"X24"	32"x26"x72"	4	70
SUS-244272-4	42"X24"	44"x26"x72"	4	95
SUS-245472-4	54"X24"	56"x26"x72"	4	112

ALL DIMENSIONS ARE TYPICAL. TOLERANCE +/- .500". JOHN BOOS & CO. RESERVES THE RIGHT TO CHANGE SPECIFICATIONS WITHOUT NOTICE.

# DETAILED SPECIFICATIONS

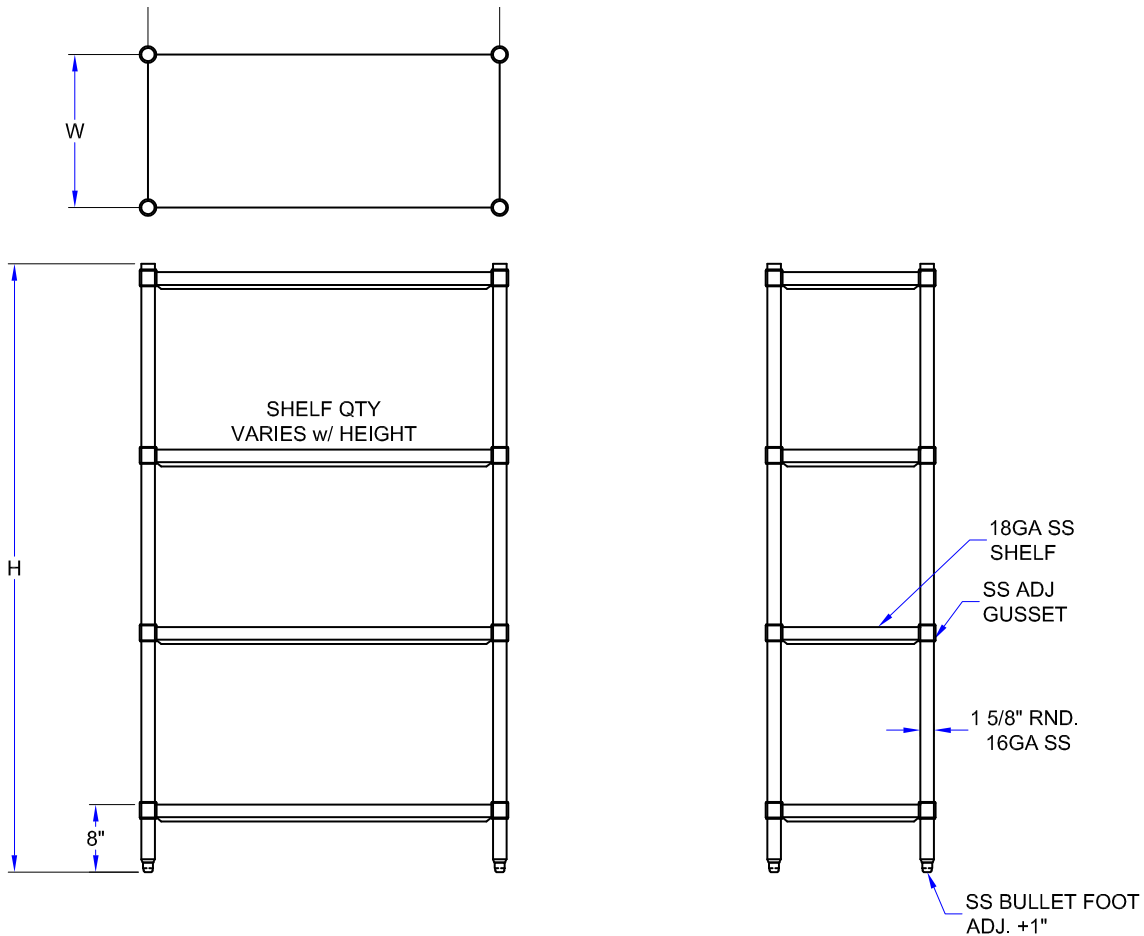

## "SUS" DRY STORAGE SHELVES

MODEL	SHELF SIZE (L X W)	OVERALL SIZE (L X W X H)	# OF SHELVES	WEIGHT (LBS)
SUS-183036-2	30"X18"	32"x20"x36"	2	32
SUS-184236-2	42"X18"	44"x20"x36"	2	37
SUS-185436-2	54"X18"	56"x20"x36"	2	45
SUS-243036-2	30"X24"	32"x26"x36"	2	36
SUS-244236-2	42"X24"	44"x26"x36"	2	48
SUS-245436-2	54"X24"	56"x26"x36"	2	57
SUS-183060-3	30"X18"	32"x20"x60"	3	47
SUS-184260-3	42"X18"	44"x20"x60"	3	55
SUS-185460-3	54"X18"	56"x20"x60"	3	67
SUS-243060-3	30"X24"	32"x26"x60"	3	54
SUS-244260-3	42"X24"	44"x26"x60"	3	72
SUS-245460-3	54"X24"	56"x26"x60"	3	85
SUS-183072-4	30"X18"	32"x20"x72"	4	61
SUS-184272-4	42"X18"	44"x20"x72"	4	72
SUS-185472-4	54"X18"	56"x20"x72"	4	88
SUS-243072-4	30"X24"	32"x26"x72"	4	70
SUS-244272-4	42"X24"	44"x26"x72"	4	95
SUS-245472-4	54"X24"	56"x26"x72"	4	112

ALL DIMENSIONS ARE TYPICAL. TOLERANCE +/- .500". JOHN BOOS & CO. RESERVES THE RIGHT TO CHANGE SPECIFICATIONS WITHOUT NOTICE.