

Steel finish



Icon finish

Modular electric deck oven

2 decks composition

serieS is the most advanced and customizable oven in the world, ideal for **perfect baking of pizza, bakery, pastry, and gastronomy.**

Customize serieS choosing dimensions, number, and type of baking chamber, **material** for baking surface (refractory steel deck, or bakingstone), door opening, Steel or Icon finish, and so much more. serieS meets all production needs thanks to specific and integrable baking chambers: **Multibake, Stonebake, Pastrybake** and **Steambake**. Power consumption reduced by 35% and baking speed increased by 20% are the features that make serieS the evolution of baking; the professional oven for those who want to extend their business with a single tool



OPERATION

- Heated by highly performing armoured heating elements or spiral heating (stonebake)
- Temperature management using P.I.D. permit the automatic energy regulation to the quantity of the baked product Adaptive-Power® Technology
- Separated temperature management of ceiling and floor Dual-Temp® Technology
- Separated power management of ceiling and floor Dual-Power® Technology
- Automatic cleaning program for carbonization
- Maximum temperature reached 842°F
- Continuous temperatures monitoring in baking chamber by 2 thermocouples
- Vapour ducting using manual butterfly valve

CONSTRUCTION

- Structure made in folded stainless steel
- Side panels in painted sheet metal
- Channel hood
- Steam duct in stainless steel plate
- Stainless steel door, tempered glass element, door handle in stainless steel
- Aluminated steel top and side structure or refractory (stonebake)
- Refractory brick baking surface
- Double LED light
- Rock wool heat insulation

ACCESSORIES

- Leavening proofer on wheels height 23 1/2", 31 1/2"
- Stand with wheels height 15 3/4", 23 1/2", 31 1/2", 37 1/2", 41 1/2"
- Spacer element height 11 13/16"
- Bakingstone or buckle plate surface
- Additional tray holder guides for compartment and stand
- Max power optimizer (Fource® Technology)
- Door opening from bottom to top
- Lateral tool-holder for compartment
- Oversized hood, frontless hood
- Remote-Master® Technology for remote management and control

INTERNAL BAKING DIMENSIONS

Internal height	6 1/4" - 12"
Internal depth	49 3/4"
Internal width	49"
Baking surface	16,1m ²

STANDARD EQUIPMENT

- Color multilanguage display TFT 5"
- 100 customized programs with baking steps
- Eco-Standby BY™ Technology for break
- Power-Booster™ Technology for workload peaks
- Half-Load™ Technology for partial load
- Front and rear power balance Delta-Power™ Technology
- Customized Hotkey with recurring control
- Self-diagnosis with error message display
- Independent double baking Timer and Multitimer
- Weekly Timer with the possibility to program two lightings and two power off every day
- Independent security device of maximum temperature
- USB input and WiFi module for sw update

TOP VIEW

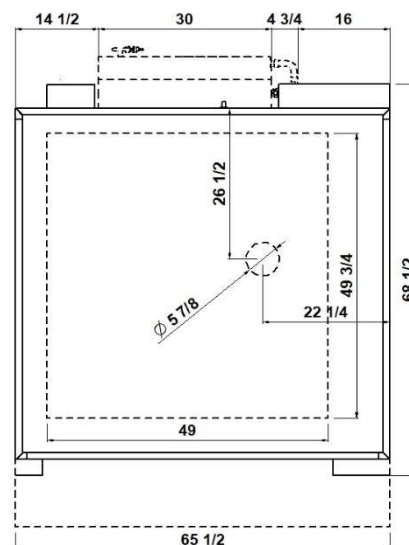

1 baking chamber height 6 1/4"

(assembled with stand height 37 1/2")

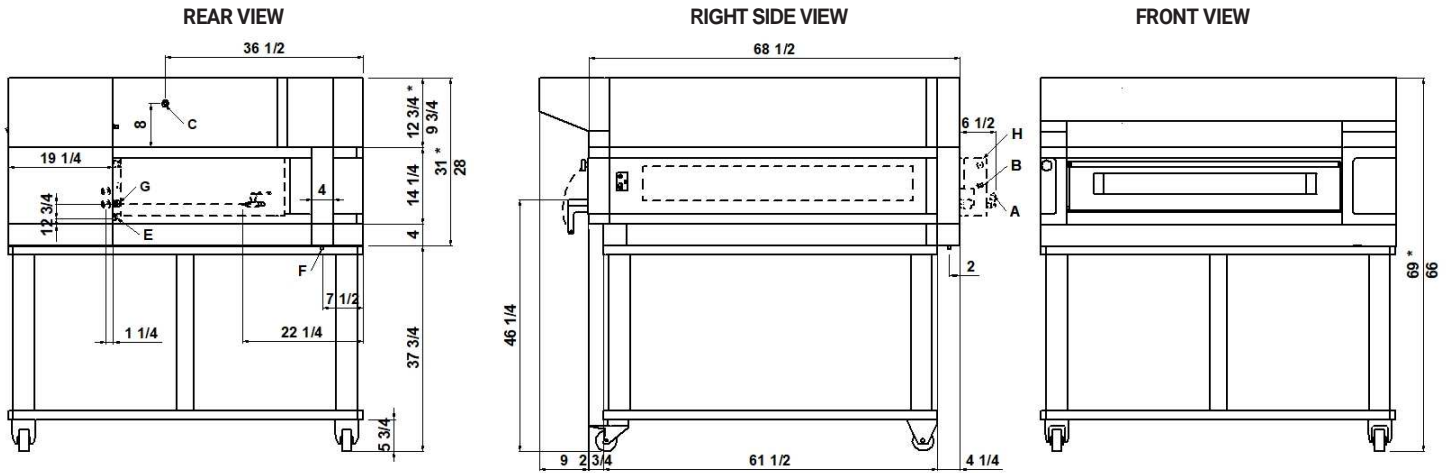

NOTE: The dimensions indicated in the views are in inches. *Dimensions refer to the oversized hood.

A Ø 5/16" steamer water outlet	B 3/4" male steamer water inlet	C Ø 5/8" Hood condensate exhaust	
E M6 equipotential screws	F Ø12 condensate exhaust	G fairleads	H Steamer 3480W (see data sheet)

DIMENSIONS

External height	18" (460mm)
External depth	68 1/2" (1738mm)
External width	65 1/2" (1660mm)
Weight	849lb (385kg)

TOTAL BAKING CAPACITY

Tray 26"x18" (600x400)mm	6
Pizza diameter 14"	10
Pizza diameter 18"	6

SHIPPING INFORMATION

Packed in wooden crate	
Height	34" (860mm)
Depth	87" (2173mm)
Width	74" (1870mm)
Weight	959lb (435kg)

When combined with proofer or stand:	
Max height	71" (1810mm)
Max weight	1354lb (610kg)

FEEDING AND POWER

Standard feeding	
A.C. V208 3ph	
Frequency	60Hz
Max power	17,3kW/DECK
*Average power cons	5,2kWh
Ampère max	48A/DECK (V208 3ph)
Connecting cable for each chamber	8AWG/DECK
Power supply (optional proofer)	
A.C. V(208/240) 1ph 60Hz	
Max power	1,8kW
*Average power cons	0,9kWh
Conn. Cable 14AWG – Ampère	7,5A

* This value is subject to variation according to the way in which the equipment is used
NOTE: MORETTI FORNI S.P.A. reserves the right to modify the characteristics of the products illustrated in this publication without prior notice

2 baking chambers height 6 1/4"
(assembled with proofer height 31 1/2")

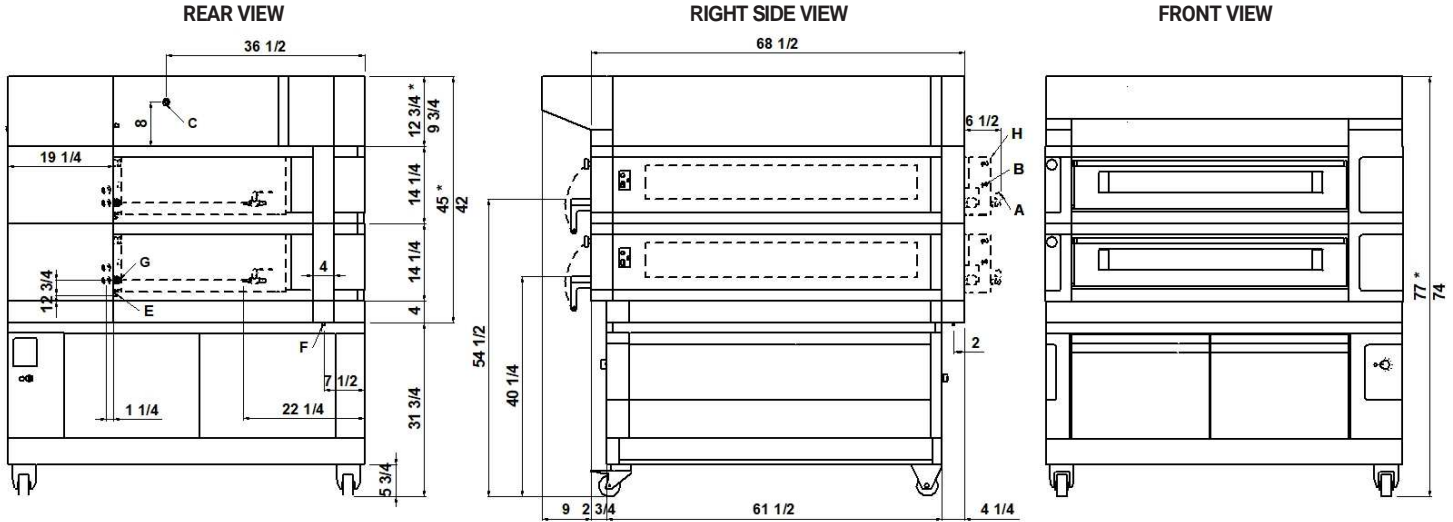

NOTE: The dimensions indicated in the views are in inches. *Dimensions refer to the oversized hood.

A Ø 5/16" steamer water outlet	B 3/4" male steamer water inlet	C Ø 5/8" Hood condensate exhaust	
E M6 equipotential screws	F Ø12 condensate exhaust	G fairleads	H Steamer 3480W (see data sheet)

DIMENSIONS

External height	32 1/4" (820mm)
External depth	68 1/2" (1738mm)
External width	65 1/2" (1660mm)
Weight	1387lb (629kg)

SHIPPING INFORMATION

Packed in wooden crate	
Height	48" (1220mm)
Depth	87" (2173mm)
Width	74" (1870mm)
Weight	1519lb (689kg)

FEEDING AND POWER

Standard feeding	
A.C. V208 3ph	
Frequency	60Hz
Max power	17,3kW/DECK
*Average power cons	5,2kWh
Ampère max	48A/DECK (V208 3ph)
Connecting cable for each chamber	8AWG/DECK
Power supply (optional proofer)	
A.C. V(208/240) 1ph 60Hz	
Max power	1,8kW
*Average power cons	0,9kWh
Conn. Cable 14AWG – Ampère	7,5A

TOTAL BAKING CAPACITY

Tray 26"x18" (600x400)mm	12	When combined with proofer or stand:	
Pizza diameter 14"	20	Max height	80" (2020mm)
Pizza diameter 18"	12	Max weight	1905lb (864kg)

* This value is subject to variation according to the way in which the equipment is used

NOTE: MORETTI FORNI S.P.A. reserves the right to modify the characteristics of the products illustrated in this publication without prior notice

3 baking chambers height 6 1/4"
(assembled with proofer height 23 1/2")

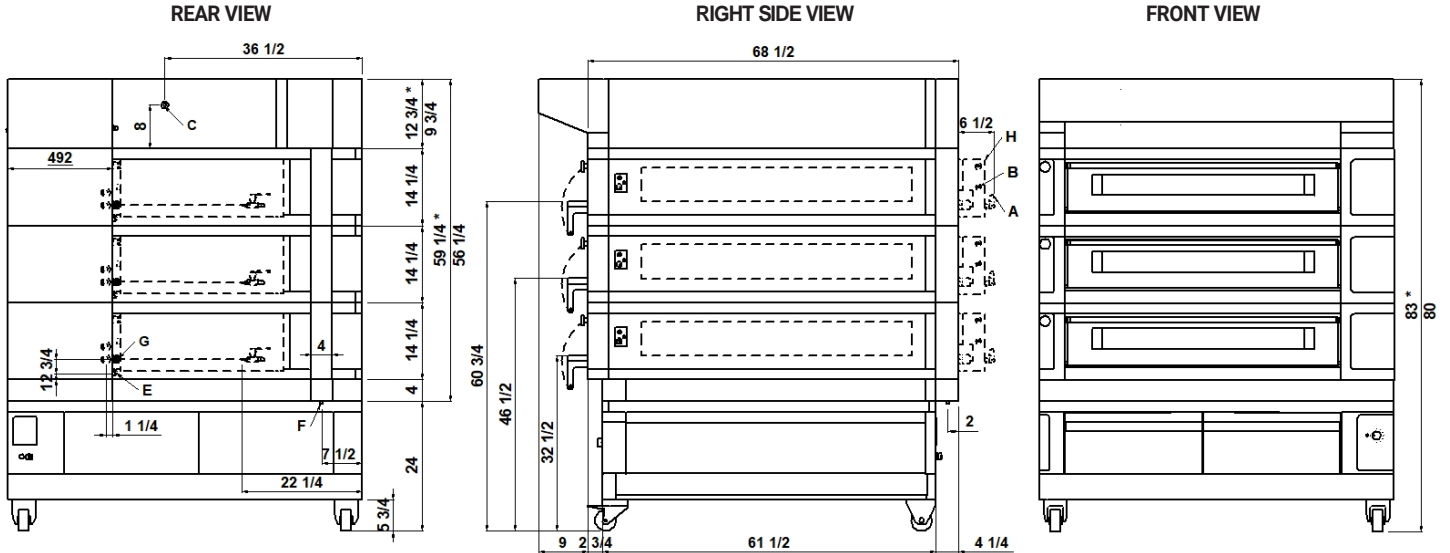

NOTE: The dimensions indicated in the views are in inches. *Dimensions refer to the oversized hood.

A Ø 5/16" steamer water outlet	B 3/4" male steamer water inlet	C Ø 5/8" Hood condensate exhaust	
E M6 equipotential screws	F Ø12 condensate exhaust	G fairleads	H Steamer 3480W (see data sheet)

DIMENSIONS

External height	38" (960mm)
External depth	68 1/2" (1738mm)
External width	65 1/2" (1660mm)
Weight	1925lb (873kg)

SHIPPING INFORMATION

Packed in wooden crate	
Height	62" (1580mm)
Depth	87" (2173mm)
Width	74" (1870mm)
Weight	2079lb (943kg)

FEEDING AND POWER

Standard feeding	
A.C. V208 3ph	
Frequency	60Hz
Max power	17,3kW/DECK
*Average power cons	5,2kWh
Ampère max	48A/DECK (V208 3ph)
Connecting cable for each chamber	8AWG/DECK
Power supply (optional proofer)	
A.C. V(208/240) 1ph 60Hz	
Max power	1,8kW
*Average power cons	0,9kWh
Conn. Cable 14AWG – Ampère	7,5A

TOTAL BAKING CAPACITY

Tray 26"x18" (600x400)mm	18	When combined with proofer or stand:	
Pizza diameter 14"	30	Max height	86" (2180mm)
Pizza diameter 18"	18	Max weight	2432lb (1103kg)

* This value is subject to variation according to the way in which the equipment is used
NOTE: MORETTI FORNI S.P.A. reserves the right to modify the characteristics of the products illustrated in this publication without prior notice

2 baking chambers height 6 1/4" + 12"
(assembled with proofer height 31 1/2")

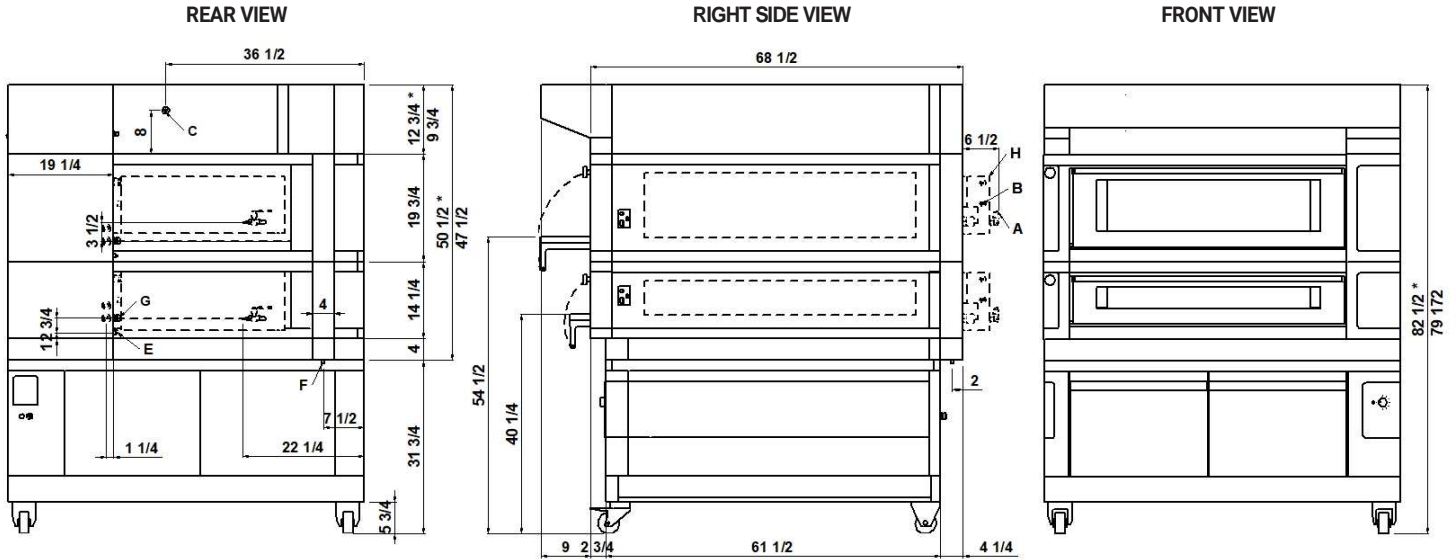

NOTE: The dimensions indicated in the views are in inches. *Dimensions refer to the oversized hood.

A Ø 5/16" steamer water outlet	B 3/4" male steamer water inlet	C Ø 5/8" Hood condensate exhaust	
E M6 equipotential screws	F Ø12 condensate exhaust	G fairleads	H Steamer 3480W (see data sheet)

DIMENSIONS

External height	52" (1320mm)
External depth	68 1/2" (1738mm)
External width	65 1/2" (1660mm)
Weight	1444lb (655kg)

SHIPPING INFORMATION

Packed in wooden crate	
Height	53 1/2" (1360mm)
Depth	87" (2173mm)
Width	74" (1870mm)
Weight	1576lb (715kg)

FEEDING AND POWER

Standard feeding	
A.C. V208 3ph	
Frequency	60Hz
Max power	17,3kW/DECK
*Average power cons	5,2kWh
Ampère max	48A/DECK (V208 3ph)
Connecting cable for each chamber	8AWG/DECK
Power supply (optional proofer)	
A.C. V(208/240) 1ph 60Hz	
Max power	1,8kW
*Average power cons	0,9kWh
Conn. Cable 14AWG – Ampère	7,5A

TOTAL BAKING CAPACITY

Tray 26"x18" (600x400)mm	12	When combined with proofer or stand:	
Pizza diameter 14"	20	Max height	85" (2160mm)
Pizza diameter 18"	12	Max weight	1905lb (864kg)

* This value is subject to variation according to the way in which the equipment is used
NOTE: MORETTI FORNI S.P.A. reserves the right to modify the characteristics of the products illustrated in this publication without prior notice

3 baking chambers height 6 1/4" + 6 1/4" + 12"
(assembled with proofer height 23 1/2")

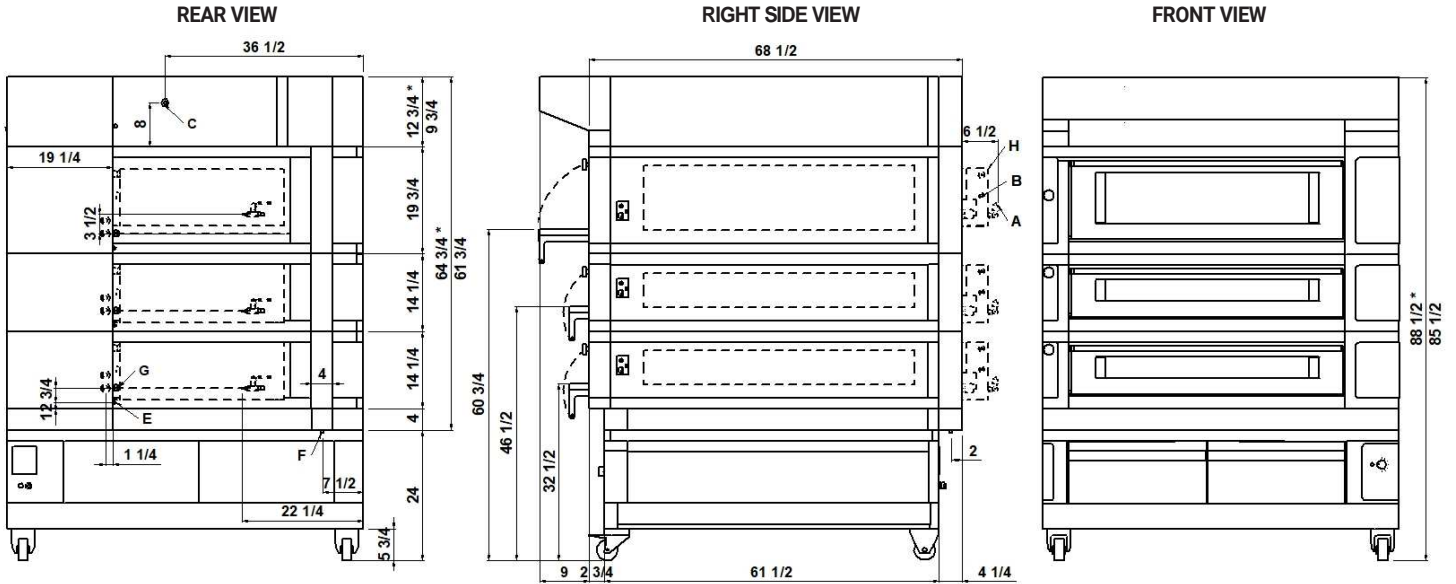

NOTE: The dimensions indicated in the views are in inches. *Dimensions refer to the oversized hood.

A Ø 5/16" steamer water outlet	B 3/4" male steamer water inlet	C Ø 5/8" Hood condensate exhaust	
E M6 equipotential screws	F Ø12 condensate exhaust	G fairleads	H Steamer 3480W (see data sheet)

DIMENSIONS

External height	1320mm
External depth	1738mm
External width	65 1/2" (1660mm)
Weight	2035lb (923kg)

TOTAL BAKING CAPACITY

Tray 26"x18" (600x400)mm	18
Pizza diameter 14"	30
Pizza diameter 18"	18

SHIPPING INFORMATION

Packed in wooden crate	
Height	73 1/4" (1860mm)
Depth	87" (2173mm)
Width	74" (1870mm)
Weight	2211lb (1003kg)

When combined with proofer or stand:	
Max height	86" (2180mm)
Max weight	2432lb (1103kg)

FEEDING AND POWER

Standard feeding	
A.C. V208 3ph	
Frequency	60Hz
Max power	17,3kW/DECK
*Average power cons	5,2kWh
Ampère max	48A/DECK (V208 3ph)
Connecting cable for each chamber	8AWG/DECK
Power supply (optional proofer)	
A.C. V(208/240) 1ph 60Hz	
Max power	1,8kW
*Average power cons	0,9kWh
Conn. Cable 14AWG – Ampère	7,5A

* This value is subject to variation according to the way in which the equipment is used
NOTE: MORETTI FORNI S.P.A. reserves the right to modify the characteristics of the products illustrated in this publication without prior notice

S125
TECHNICAL DATA

SHIPPING INFORMATION H6 1/4"		S125E_1_16	S125E_2_16	S125E_3_16
Packed in wooden crate	Height	34" (860mm)	48" (1220mm)	62" (1580mm)
	Icon height	38" (960mm)	52" (1320mm)	66" (1680mm)
	Weight	959lb (435kg)	1519lb (689kg)	2079lb (943kg)
When combined with proofer or Stand	Max. height	71" (1810mm)	80" (2020mm)	86" (2180mm)
	Max. icon height	75" (1910mm)	84" (2120mm)	90" (2280mm)
	Max. weight	1345lb (610kg)	1905lb (864kg)	2432lb (1103kg)
SHIPPING INFORMATION H12"		S125E_1_30	S125E_2_30	S125E_3_30
Packed in wooden crate	Height	39" (1000mm)	59" (1500mm)	79" (2000mm)
	Icon height	43" (1100mm)	63" (1600mm)	83" (2100mm)
	Weight	994lb (451kg)	1590lb (721kg)	2185lb (991kg)
When combined with proofer or Stand	Max. height	77" (1950mm)	95" (2400mm)	102" (2600mm)
	Max. icon height	81" (2050mm)	100" (2500mm)	106" (2700mm)
	Max. weight	1380lb (626kg)	1975lb (896kg)	2538lb (1151kg)
SHIPPING INFORMATION STONEBAKE		S125R_1_16	S125R_2_16	S125R_3_16
Packed in wooden crate	Height	34" (860mm)	48" (1220mm)	62" (1580mm)
	Icon height	38" (960mm)	52" (1320mm)	66" (1680mm)
	Weight	1340lb (608kg)	2216lb (1005kg)	3091lb (1402kg)
When combined with proofer or Stand	Max. height	71" (1810mm)	80" (2020mm)	86" (2180mm)
	Max. icon height	75" (1910mm)	84" (2120mm)	90" (2280mm)
	Max. weight	1726lb (783kg)	2601lb (1180kg)	3444lb (1562kg)

FEEDING AND POWER (EACH DECK NEEDS TO BE CONNECTED INDEPENDENTLY AND THE LOAD SHOWN BELOW ARE PER DECK)	A.C. V208 3ph 60Hz	Multibake Stonebake	Max power	kW	17,3
			*Medium cons/hour	kWh	5,2
			Ampère Max	A/DECK	48
	Connecting cable	AWG/DECK	8		
	A.C. V208 3ph 60Hz	Steambake	Max power	kW	15,0
			*Medium cons/hour	kWh	4,5
			Ampère Max	A/DECK	42
	Connecting cable	AWG/DECK	8		
	A.C. V208 3ph 60Hz	Pastrybake	Max power	kW	11,8
			*Medium cons/hour	kWh	3,5
			Ampère Max	A/DECK	33
	Connecting cable	AWG/DECK	10		
	A.C. V(208/240) 1ph 60Hz	Proofer	Max power	kW	1,8
			*Medium cons/hour	kWh	0,9
			Ampère Max	A/DECK	7,5
	Connecting cable	AWG/DECK	14		

MAX TEMPERATURE	Multibake/Stonebake	°F/°C	842°F	450°C
	Steambake		662°F	350°C
	Pastrybake		518°F	270°C

* This value is subject to variation according to the way in which the equipment is used
NOTE: MORETTI FORNI S.P.A. reserves the right to modify the characteristics of the products illustrated in this publication without prior notice