

Cleveland

TWIN MIXER KETTLE, DIRECT STEAM
LEG MOUNTED CONSOLE TYPE
TILTING, 2/3 STEAM JACKETED

Project _____
Item _____
Quantity _____
FCSI Section 11400 _____
Approved _____
Date _____

Mixer Kettles

Models

- TMKDL-40-T • TMKDL-100-T
- TMKDL-60-T • TMKDL-125-T
- TMKDL-80-T • TMKDL-150-T



Shown with optional Power Tilt
& Product Temperature Control

Standard Features

- 3 HorsePower Hydraulic powered Agitator, Scraper and Bridge Lift
- Infinitely Variable Scraper Speed Control from 0 to 40 rpm
- Infinitely Variable Ratio between Scraper and Agitator: Agitator rotates from 0 to 8 times the speed of the Scraper
- Removable (without tools) Nylon Blades scrape the entire Jacketed Surface
- Safety Device prevents high speed Starts
- Mixing stops when bridge is lifted - includes safety cover and screen
- Agitator and Scraper are Bayonet Mounted for easy removal
- Factory installed Chrome-Plated Steam Control Kit
- Tilt Mechanism of roller bearings and case hardened self-locking worm and segment gear
- Power Tilt standard on 150 gallon model
- 3" diameter Quick Opening Butterfly Valve
- Hot and Cold Water Faucet
- Condensate Valve with Insulated Handle
- 50 psi Steam Jacket Rating on 40 - 100 gallon models
- 35 psi Steam Jacket Rating on 125 & 150 gallon models
- All Plumbing, Electrical, Hydraulics enclosed in Stainless Steel Consoles
- Enclosed, 10 Gauge Stainless Steel hydraulically operated Mixer Bridge
- Kettles and all exterior surface are Stainless Steel
- Large Pouring Lip
- Gallon Markings stamped into Scraper Shaft
- Level adjustable solid feet (for floor bolting)
- Standard 208-240 volts, 60 Hz, 3 phase, 4 wire
- Typical approvals include NSF and ASME
- 316 Stainless Steel Interior
- Two piece cover with safety screen

Short Form Specifications

Shall be CLEVELAND Tilting Twin Mixer Kettle Model TMKDL - _____ -T,

Console/Leg mounted, Direct Steam Mixer Kettles with _____ psi Steam Jacket Ratings. 3 H.P. Hydraulic powered Scraper/Agitator and Bridge Lift. 0-40 rpm Scraper Speed with Variable Scraper to Agitator Ratio from 1-1 to 8-1. Type 316 Stainless Steel interior, Stainless Steel enclosed Mixer Bridge. All Plumbing, Electrical and Hydraulics enclosed in Consoles. Gallon markings, Bayonet Mounted Scraper and Agitator. 3" Butterfly Valve. Hot and Cold Water Faucet. Steam Control Kit. Safety Device prevents high speed starts; Mixer stops when Bridge is lifted. Kettles and all exterior surfaces are Stainless Steel. 316 Stainless Steel Interior.

Options & Accessories

- Product Time/Temperature Controls and Indicators (DTCI)
- Automatic Water Cooling (AWC-2)
- Alternate Draw-Off Valves
- Food Strainer (FS)
- Flow Diverter (FD)
- Pan Carrier (PCK)
- Swing Funnels (SF-1 or SF-2)
- Pressure Reducing Valve (PRV)
- Power Tilt (PT) where not standard
- Kettle Accessory Kit (KAK) includes:
 - Clean-up Brush (CB)
 - 36" Kettle Paddle (KP)
 - 36" Kettle Whip (KW)
 - 36" Kettle Brush (KB)
 - Draw-off Brush (DB)
 - 24 oz. Ladle (KL)
- Water Meter (GMF or LMF) built into system
- Accessories for connection to food pumps
- Leg Extensions (ELTMK)
- Digital Data Logger for Time and Temperature

KE004046-97

Cleveland

DIMENSIONS ("/mm)

GAL./LIT.	A	B	C	D	E	F	G	H	J1	J2	K	L	M	N	O	P	Q	R	S	T	U	V	W	X	Y	Z	AA	BB	CC	DD	EE	FF	GG	HH	LL	MM
40/150	98.00	58.00	26.00	40.50	50.00	69.25	7.50	37.75	30.00	25.00	12.00	12.25	36.38	23.13	27.375	36.00	18.375	28.00	10.00	18.00	26.50	7.75	5.25	6.50	5.75	1.75	12.50	12.50	60.50	25.00	6.50	13.625	na	39.00	5.375	74.25
2489	1473	660	1029	1270	1759	191	959	762	635	305	311	924	587	695	914	467	711	254	457	673	197	133	165	146	44	318	318	1537	635	165	346	na	991	137	1886	
60/225	105.00	61.50	29.50	40.50	50.00	70.25	7.50	41.25	31.00	28.00	8.50	7.63	39.13	23.13	27.375	36.00	18.375	28.00	10.00	18.00	26.50	7.75	5.25	6.50	5.75	1.75	12.50	12.75	64.25	28.00	8.00	14.88	na	40.75	5.375	75.25
2667	1562	749	1029	1270	1784	191	1048	787	787	216	194	994	587	695	914	467	711	254	457	673	197	133	165	146	44	318	324	1632	711	203	378	na	1035	137	1911	
80/300	112.00	66.00	33.00	42.50	52.00	74.75	9.50	44.75	32.00	29.00	8.50	6.94	39.88	23.13	27.375	36.00	18.375	28.00	10.00	18.00	26.50	7.75	5.25	6.50	5.75	1.75	12.50	13.50	68.50	30.00	9.00	16.13	na	42.75	5.375	79.75
2945	1651	838	1080	1321	1899	241	1137	813	711	216	176	1013	587	695	914	467	711	254	457	673	197	133	165	146	44	318	343	1740	762	229	410	na	1086	137	2026	
100/375	121.00	68.50	35.50	44.50	54.00	78.25	11.50	48.25	33.00	29.00	8.50	6.69	41.13	23.13	29.375	36.00	18.375	28.00	12.00	18.00	26.50	7.75	5.25	6.50	5.75	2.50	12.50	15.75	73.25	32.00	10.00	17.00	3.25	43.75	5.375	83.25
3073	1756	902	1130	1372	1968	292	1226	838	737	216	170	1045	587	746	914	467	711	305	457	673	197	133	165	146	64	318	400	1861	813	254	432	83	1111	137	2115	
125/475	130.00	74.00	40.00	44.50	54.00	83.00	11.50	52.75	34.00	30.00	8.00	5.00	40.375	23.13	29.375	36.00	18.375	28.00	12.00	18.00	26.50	7.75	5.25	6.50	5.75	2.50	12.50	16.50	81.50	35.00	11.50	18.50	3.25	46.00	5.375	86.00
3302	1880	1016	1130	1372	2108	292	1340	864	782	203	127	1026	587	746	914	467	711	305	457	673	197	133	165	146	64	318	419	2070	889	292	470	83	1168	137	2235	
150/575	130.00	74.00	40.00	48.50	58.00	87.00	15.50	52.75	34.00	32.00	7.25	5.37	44.00	23.13	29.375	36.00	18.375	28.00	12.00	18.00	26.50	7.75	5.25	6.50	5.75	2.50	12.50	16.50	81.50	35.00	11.50	18.50	3.25	46.00	5.375	92.00
3302	1800	1016	1232	1473	2210	394	1340	864	813	184	137	1118	587	746	914	467	711	305	457	673	197	133	165	146	64	318	419	2070	889	292	470	83	1168	137	2337	

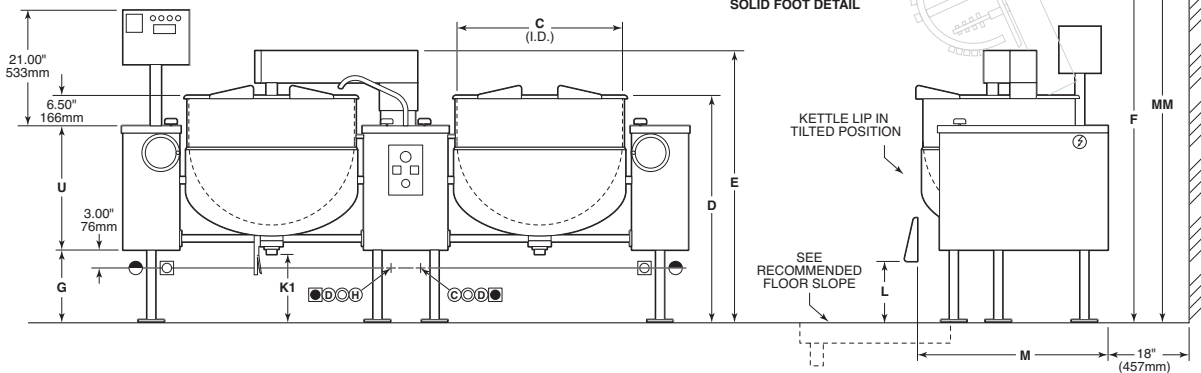
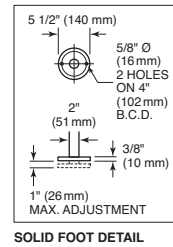
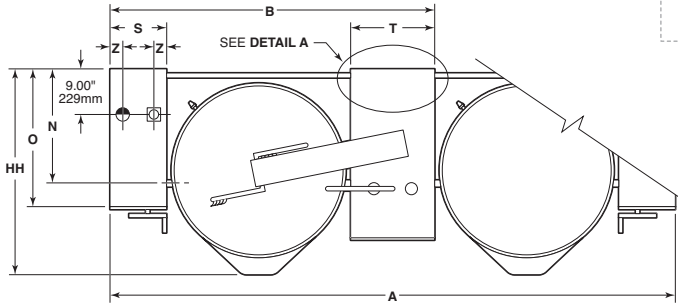
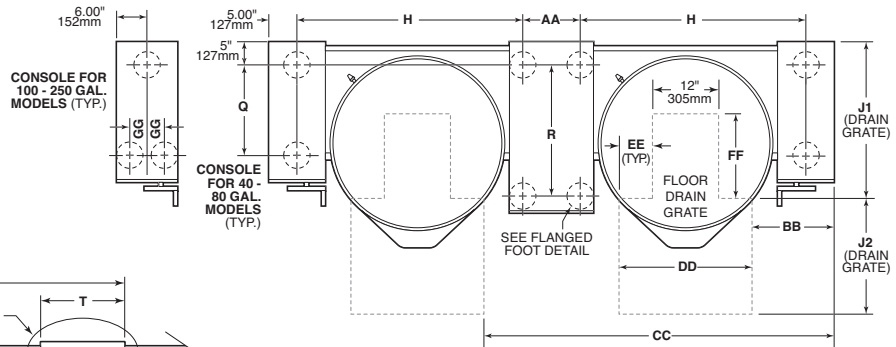
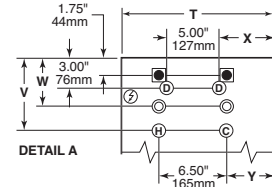
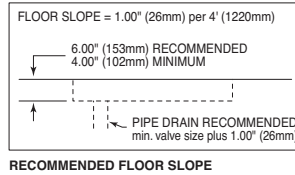

ELECTRICAL

Supply Voltage	Phase	Wires	HZ	Supply Amps	Wire Size
200-208	3	3	60	15	12
220-240	3	3	60	14	12
380-415	3	3	60	9	14
440-480	3	3	60	7	14

STEAM JACKET RATING

PSI	35	50	70	PSI	35	50	70
40 Gal.	N/A	ST	OP	100 Gal.	N/A	ST	OP
60 Gal.	N/A	ST	OP	125 Gal.	ST	N/A	OP
80 Gal.	N/A	ST	OP	150 Gal.	ST	N/A	OP

ST - Standard, OP - Optional, N/A - Not Available

UTILITIES

- Direct Steam - 3/4" NPT (40 - 80 Gal.), 1 1/4" NPT (100 - 150 Gal.)
- Cold Water Faucet - 3/4" NPT
- Cooling Water In - 3/4" NPT
- Condensate Return - 3/4" NPT
- Cooling Water Out - 3/4" NPT
- Hot Water Faucet - 3/4" NPT
- Automatic Drain - 3/8" NPT

CLEARANCE

- Right - 0, Left - 0
- Rear - 18" (457mm) Recommended
- 0 - Minimum

NOTES:

Cleveland Range reserves right of design improvement or modification, as warranted.

Many regional, state and local codes exist and it is the responsibility of the owner and installer to comply with the codes.

Installation of backflow preventers, vacuum breakers and other specific code requirements is the responsibility of the owner and installer.

Cleveland Range equipment is built to comply with applicable standards for manufacturers. Included among those approval agencies are U.L., A.G.A., NSF, ASME/N.Bd., CSA, CGA, ETL and others.

(NOT TO SCALE)

Mixer Kettles

760 Beta Drive, Unit D
Mayfield Village, Ohio 44143

Tel 1.216.481.4900
Fax 1.216.481.3782
Email steam@clevelandrange.com

www.clevelandrange.com
Section 8, Page 16
11 / 2023

Timeless Quality, Trusted For Life®