

# PASS-THRU FREEZER (0°F)

**Model: DL3F-PT**

*Designer-line*

## 3-Section Pass-Thru Freezer

**DL3F-PT** - Stainless steel front, aluminum end panels and interior  
**DL3F-SA-PT** - Stainless steel exterior, aluminum interior  
**DL3F-SS-PT** - Stainless steel exterior and interior



## Options and Accessories

(upcharge and lead times may apply)

Additional epoxy coated steel shelves	Casters
Chrome or stainless steel shelves	Special electrical req. (consult factory)
Pan slide assemblies	<b>Correctional Facility Options</b>
Rehinging of doors (consult factory)	• One way security screws
Expansion valve system	• Locking hasp (lock not included)
Custom laminates	• Stainless steel mesh cover
Half doors	• Coverless hinges

Consult factory for other model configurations, options and accessories.

**Continental**  
 Refrigerator

Toll-Free: 800-523-7138  
 Phone: 215-244-1400  
 Fax: 215-244-9579

539 Dunksferry Road  
 Bensalem, PA 19020  
[www.continentalrefrigerator.com](http://www.continentalrefrigerator.com)

Project Name:

Model Specified:

Location:

Item No:

Quantity:

AIA #:

SIS #:

## Standard Model Features

### REFRIGERATION SYSTEM

Self contained, performance rated "plug" refrigeration system  
 Environmentally safe R-404A refrigerant  
 Refrigeration system is readily accessible on top of cabinet, separate from the "food zone"  
 Automatic, hot gas condensate evaporator

### CABINET ARCHITECTURE

3" non-CFC polyurethane foam insulation  
 Smooth, polished chrome workflow door handles  
 Cam action, lift off hinges  
 Self closing doors  
 Magnetic snap-in Santoprene™ door gaskets  
 Cylinder lock in each door  
 Heavy duty pilaster strips  
 Heavy duty, epoxy coated steel shelves  
 Adjustable 6" stainless steel legs

### MODEL FEATURES

LED interior lighting  
 Electronic controller with digital display & hi-low alarm  
 Automatic electric defrost  
 Top and side air distribution ducts  
 Cabinet upper side panels and refrigeration "plug" system can be removed and reinstalled at job site

APPROVAL:

# Model Specifications

## DIMENSIONAL DATA

Net Capacity (cubic feet)	70 (1982 cu l)
Width, Overall (inches)	78 (1981 mm)
Depth, Overall (inches) (including handles)	38 ¾ (984 mm)
Depth [less doors] (inches)	32 (813 mm)
Depth [doors open 90°] (inches)	79 (2007 mm)
Clear Door Width (inches)	19 ¾ (492 mm)
Clear Door Height (inches)	58 ⅝ (1489 mm)
Height, Overall (inches) (including 5" casters)	85 ¾ (2178 mm)
Number of Door(s)	6
Number of Shelves	9
Shelf Area (square feet)	61.2 (5.7 sq m)
Tray Slide Capacity (per section)	24

## REFRIGERANT DATA

Condensing Unit Size (H.P.)	1
Capacity (BTU per hour)*	4010

## ELECTRICAL DATA

Voltage (International)	115/208-230/60/1 (220/50/1)
Feed Wires (including ground)	4
Total Amps (International)	14.3 (11.8) / 9.6 (4.8)
Defrost Amps (International)	9.6 (4.8)
10 ft. Cord/Plug (International)	No (No)

## SHIPPING DATA

Height - Crated (inches)	85 ½ (2172 mm)
Width - Crated (inches)	90 (2286 mm)
Depth - Crated (inches)	42 (1067 mm)
Volume - Crated (cubic feet)	187 (3766 cu l)
Weight Std - Crated (pounds)	885 (401 kg)
Weight SS - Crated (pounds)	1000 (454 kg)
Weight Std - Uncrated (pounds)	675 (306 kg)
Weight SS - Uncrated (pounds)	790 (358 kg)

\* Rating @ -15°F evaporator, 90°F ambient  
Figures in parentheses reflect metric equivalents rounded to the nearest whole unit.

# Model Plan Views

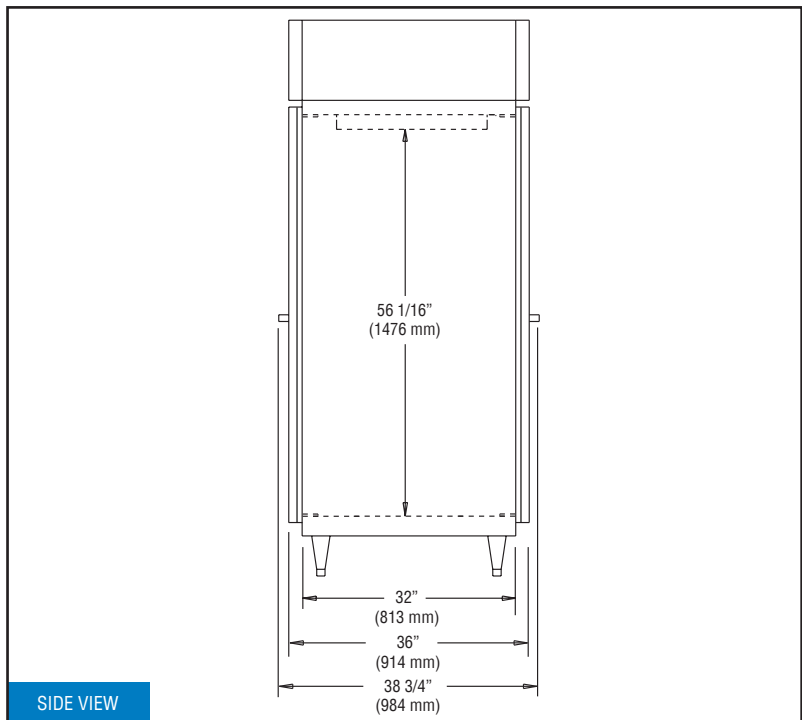
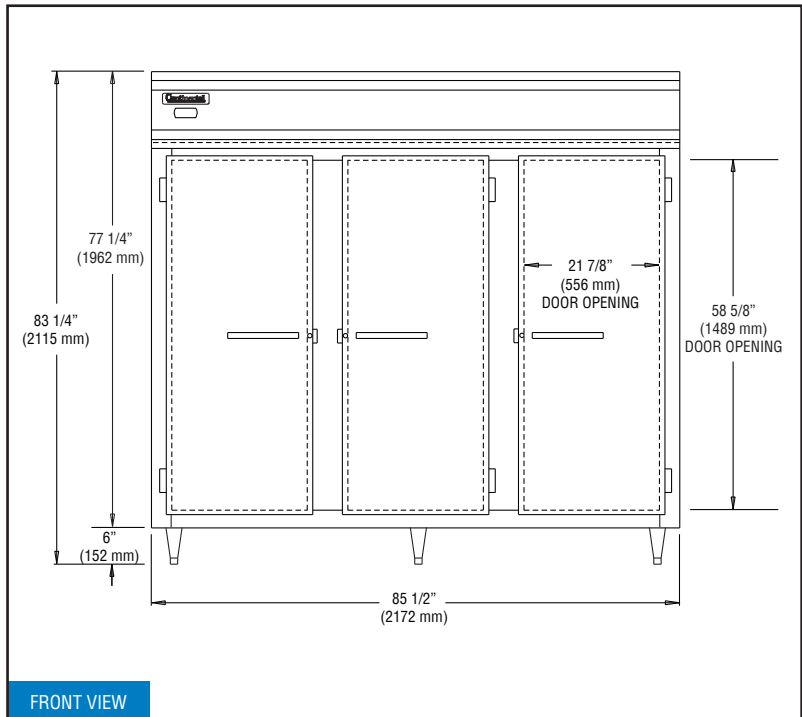

**IMPORTANT NOTE:** If the cabinet is located directly against a wall and/or under a low ceiling, a minimum clearance of 12" is required on top and 3" on sides.



Toll-Free: 800-523-7138  
Phone: 215-244-1400  
Fax: 215-244-9579

539 Dunksferry Road  
Bensalem, PA 19020  
[www.continentalrefrigerator.com](http://www.continentalrefrigerator.com)

Due to our continued efforts in developing innovative products, specifications subject to change without notice.

