



Project _____
 AIA # _____ SIS # _____
 Item # _____ Quantity _____ C.S.I. Section 114000

R/A Series

**30" Wide Pass-Thru Refrigerator
 Glass Door, 32" Deep, Self-Contained**



STANDARD PRODUCT FEATURES

- R = Stainless Steel Exterior & Interior
- A = Stainless Steel Exterior & Anodized Aluminum Interior
- Variable Speed Compressor Adapts to the Specific Work Environment
- Traulsen's Smart Control™ with LED Display
- StayClear™ Condenser Coil
- Balanced, Self-Contained Refrigeration System Using R-290 Refrigerant
- Full or Half-Height Glass Doors with Locks
- Anti-Condensate Door Perimeter Heater
- Self-Closing Door(s) with Stay Open Feature at 120 Degrees
- Stainless Steel Vertical Door Handles
- Standard Door Hinging F & R: 132WP = Right (other hings available)
- LED Lights with Exterior Switch
- Stainless Steel Breaker Caps
- Three Adjustable, Coated Wire Shelves Per Section, Supported on Shelf Pins (factory installed)
- Automatic Non-Electric Condensate Evaporator
- Magnetic Snap-In EZ-Clean™ Door Gasket(s)
- Thermostatic Expansion Valve Metering Device
- Stainless Steel One-Piece Louver Assembly
- 9' Cord & Plug Attached
- Set of (4) 6" High Adjustable Stainless Steel Legs

ACCESSORIES & OPTIONS

- SmartConnect™ Monitoring App with Wi-Fi Connectivity
- Accommodates EZ-Clean™ Tray Racks
- #1 Type Trayslides to Accommodate Either (1) 18" x 26" or (2) 14" x 18" Pans
- #4 Type Trayslides to Accommodate 19 to 19 Levels for 18" x 26" Pans
- Universal Type Trayslides to Accommodate Either (1) 18" x 26" or (2) 14" x 18" Sheet Pans, or (2) 12" x 20" Steam Table Pans
- Additional Coated Wire or Optional Stainless Steel Shelves
- 208-230/115/60/1 Voltage in Lieu of Standard 115/60/1
- Kool Klad Exterior Laminate Decor
- Set of (4) 4 1/8" or 6" High Casters in Lieu of Legs
- Other Support Options: 4 1/2" High Base in Lieu of Legs or 6" High Kickplate (for use with standard legs)



Models listed to the applicable UL, CSA and NSF standards by an approved NRTL. Consult the factory or unit data plate for additional information.

AVAILABLE CONFIGURATIONS

R Series Models

RHT132WPUT-FHG
 RHT132WPUT-HHG

Door(s)

Full Height Glass
 Half Height Glass

A Series Models

AHT132WPUT-FHG
 AHT132WPUT-HHG

Door(s)

Full Height Glass
 Half Height Glass

- GUARANTEED FOR LIFE CAM-LIFT HINGES

***Remote application without R-290 refrigerant available, see form TR35837 for details.**



ENERGY STAR® Listed Commercial Refrigerator
 For full listing visit energystar.gov

Approved by _____ Date _____ Approved by _____ Date _____

MODELS:

RHT132WPUT-HHG / AHT132WPUT-HHG

CAD and/or Revit Files Available

<https://traulsen.klccad.com/>

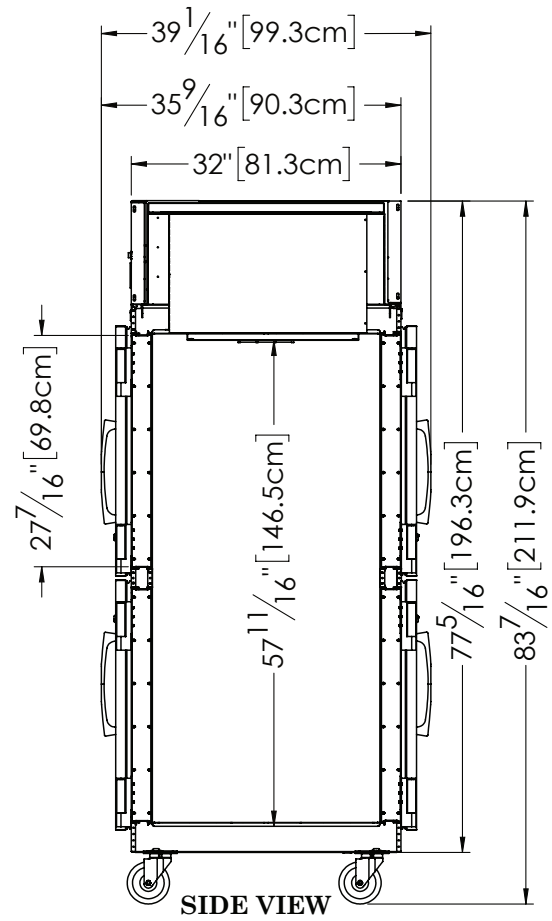
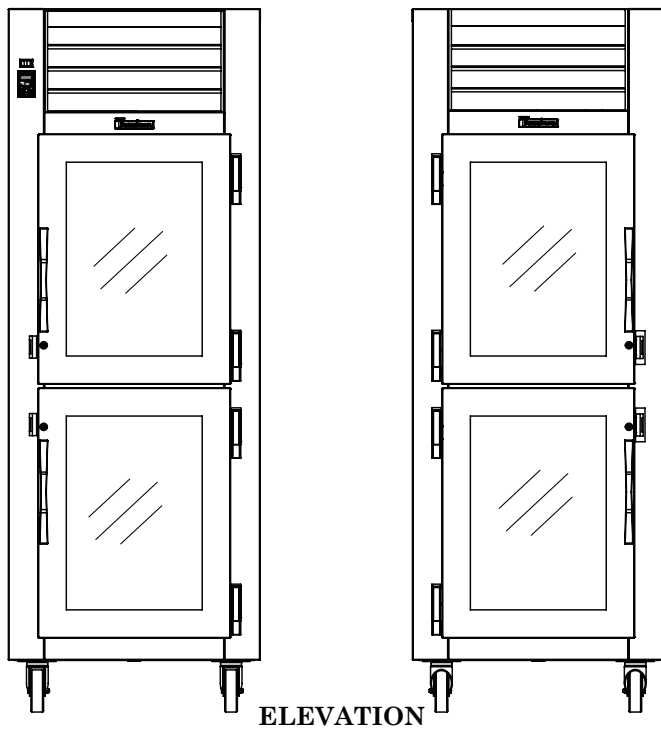
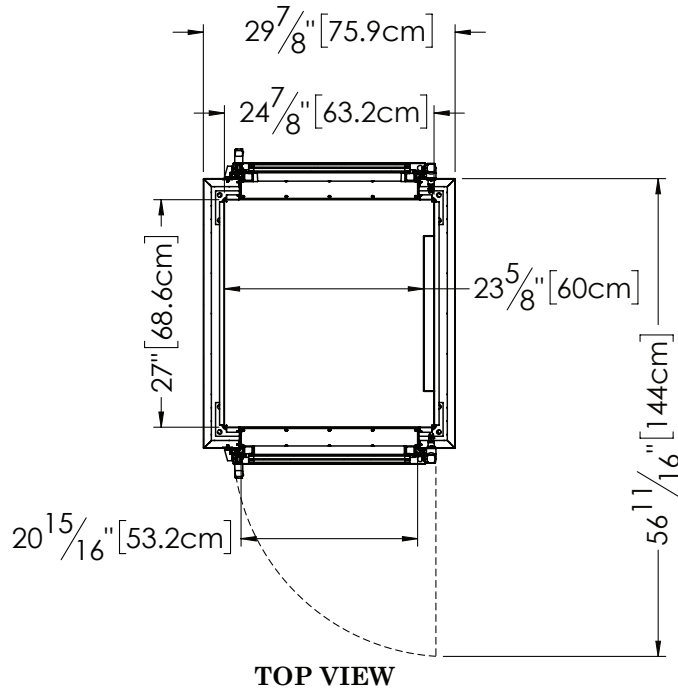



R/A Series

30" Wide Pass-Thru Refrigerator
Glass Door, 32" Deep, Self-Contained

CAD and/or Revit Files Available

<https://traulsen.klccad.com/>

MODELS:

RHT132WPUT-FHG / AHT132WPUT-FHG

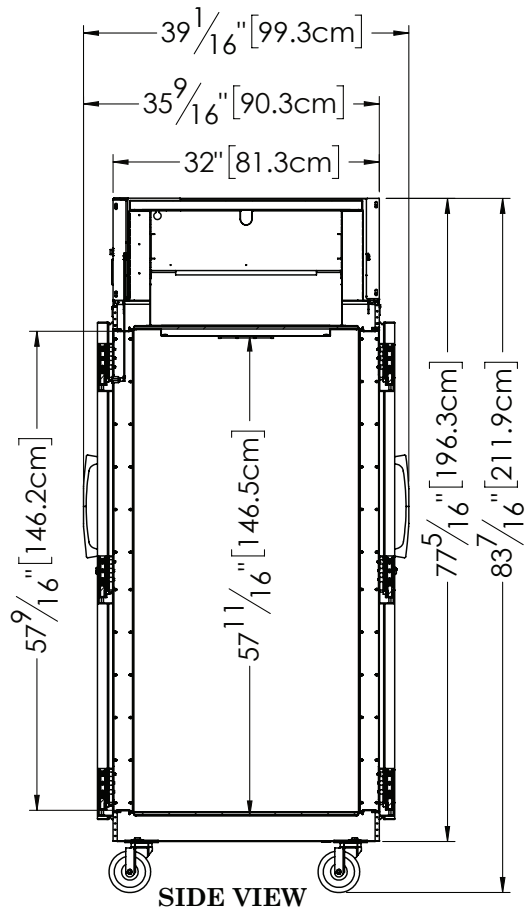
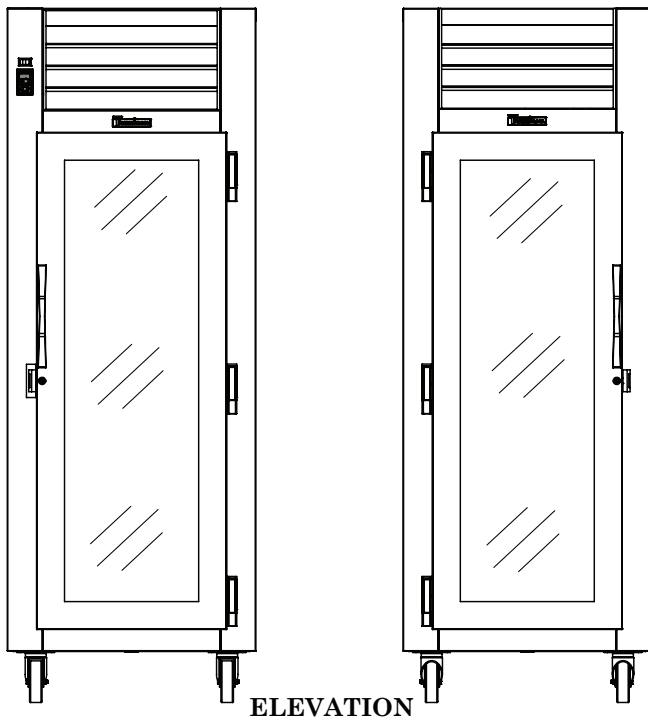
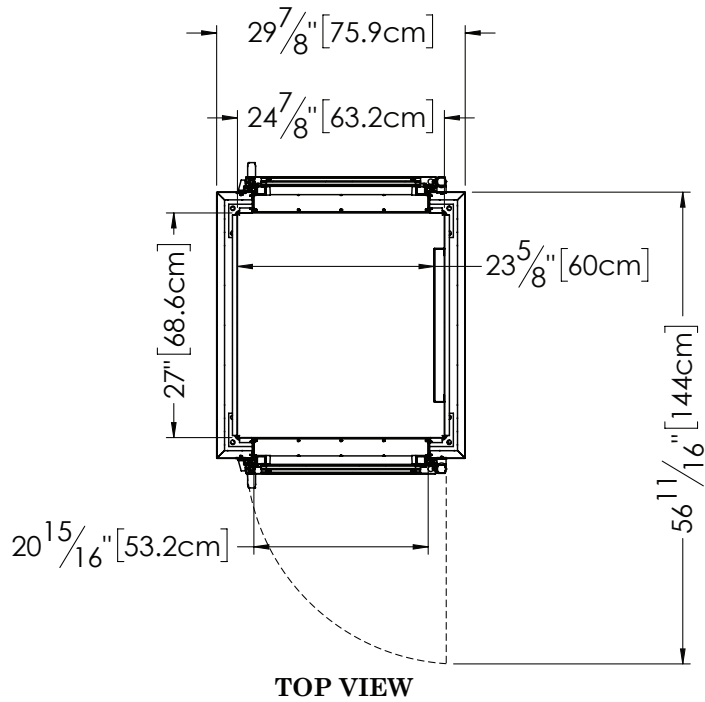

MODELS:

**RHT132WPUT-HHG, RHT132WPUT-FHG, AHT132WPUT-HHG,
 AHT132WPUT-FHG**

EQUIPMENT SPECIFICATIONS

MODELS	R/AHT132WPUT
DIMENSIONAL DATA	
Net capacity cu. ft.	25.73 (728.6 cu l)
Length - overall in.	29 7/8" (75.9 cm)
Depth - overall in.	39 1/16" (99.3 cm)
Depth - over body in.	32" (81.3 cm)
Depth - door open 90° in.	56 11/16" (144 cm)
Clear door width in.	20 15/16" (53.2 cm)
Clear half-door height in.	27 7/16" (69.8 cm)
Clear full-door height in.	57 9/16" (146.2 cm)
Height - overall on 6" legs ²	83 7/16" (211.9 cm)
No. Standard Shelves	3
Shelf area sq. ft. ³	13.46 (1.25 sq. m)
ELECTRICAL DATA	
Voltage Plug	115/60/1 NEMA 5-15P
Full Load Amperes KWH/24HR ⁴	7.6 2.27
REFRIGERATION DATA	
Refrigerant	R290
Refrigerant Charge Amount oz.	4.8 (136 g)
BTU/HR H.P. ¹	2875 1/2 HP
SHIPPING DATA	
Length - Crated in.	48" (121.9 cm)
Width - Crated in.	42" (106.7 cm)
Height - Crated in.	85" (215.9 cm)
Volume - Crated cu. ft.	99 (2803.4 cu l)
Weight - Crated lbs.	494 (224.1 kg)

CONSTRUCTION, HARDWARE, INSULATION

The R-Series interior is made from stainless steel while the A-Series interior is made from corrosion resistant anodized aluminum. For both series, the cabinet exterior front, one piece sides, louver assembly, doors and door liners are constructed of heavy gauge stainless steel. The exterior cabinet top and bottom are constructed of heavy gauge galvanized steel. Included is a set of four adjustable 6" stainless steel legs.

Doors have removable plug cylinder locks & guaranteed for life gravity action, self-closing glide hinges that stay open at 120 degrees. An external switch is included to activate interior LED lighting. The gasket design simplifies cleaning & enhances longevity. Anti-condensate heater located behind each door. The unit has seamless, polished metal corners & vertical stainless steel handles. The cabinet is insulated with high density, non-CFC, foamed in place polyurethane.

SELF-CONTAINED REFRIGERATION SYSTEM

The unit uses a top-mounted, balanced system located behind the one piece louver assembly. The R290 refrigerant is environmentally friendly & has a low GWP. It features a finless StayClear™ condenser, thermostatic expansion valve, air-cooled, hermetic variable speed compressor, plenum effect blower coil, large, high humidity evaporator coil outside the food zone & a top-mounted non-electric condensate evaporator. Operating temperatures are 34-38°F. A 9' cord and plug are provided.

CONTROL

Traulsen's Smart Control features advanced control algorithms & sophisticated diagnostic capabilities to optimize performance. Utilizing Smart Sensors, it adapts the operation of the refrigeration system to a variety of environments & usage patterns. The Smart Control also offers a complete set of visual alarms designed to alert the user to critical events such as power outages or a prolonged door opening. In the event of an alarm, a dedicated Alarm LED will illuminate, informing the user of the critical event and duration.

INTERIOR

The interior includes three factory installed pin-mounted, full-width coated wire shelves per section with no large gaps. Each shelf can support up to 225 lbs. Factory installed optional trayslides may be purchased in combination with, or in lieu of these.

WARRANTY

Both a six year parts & labor warranty and a seven year compressor warranty (self-contained models only) are provided standard.

NOTES: Figures in parentheses reflect metric equivalents.

1. Based on a 90°F ambient and 20°F evaporator.
2. 12" Top clearance preferred for optimum performance & service access.
3. Area of standard shelf compliment only, does not include storage area of additional shelves or available on cabinet bottom.
4. KWH/24HR = Kilowatts per 24 hours

When ordering please specify: Voltage, Hinging, and Options

Equipped with one NEMA 5-15P Plug



CONTINUED PRODUCT DEVELOPMENT MAY NECESSITATE SPECIFICATION CHANGES WITHOUT NOTICE.