

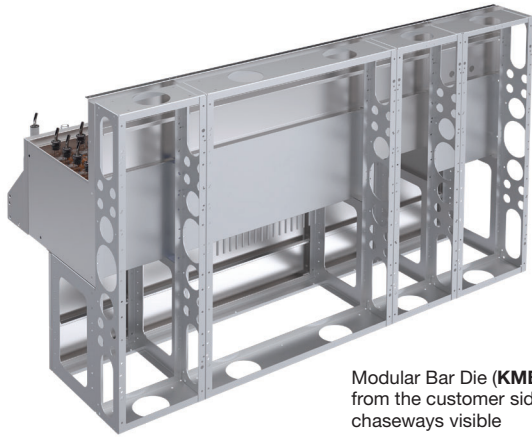

Model:                      **KMB**                      Item #:                                           Date:                       
 Project:                                           Qty:                                           Approved By:                     

## Modular Bar Die

## Royal Series Underbar



Modular Bar Die (KMB) seen from the customer side with chaseways visible

### Modular Bar Die

Model	Description	Height	Wgt./ft.
<b>KMB</b>	Modular Bar Die	41"	11 lbs.
<b>KMB-ADA</b>	Modular Bar Die ADA Counter	32"	8 lbs.

Angle calculations: 90° corner sections = 5 ft. All other angles = 2 ft.

### Accessories

Model	Description
<b>KMB-LK-W</b>	LED Light with Junction Box - Crisp White
<b>KMB-LK-B</b>	LED Light with Junction Box - Blue
<b>KMB-PS-25</b>	Power Supply for up to 10 LED Lights
<b>KMB-PS-60</b>	Power Supply for up to 25 LED Lights
<b>KMB-LD</b>	Light Dimmer
<b>KMB-EC</b>	Built-In Junction Box for Outlet
<b>KMB-PC</b>	Millwork Panel Clip - 3/4" Offset 24-Pack
<b>KMB-MT</b>	Mylar Template

### Standard Features

- Die wall structure: 16 gauge anti-corrosive galvanized steel (stainless steel upgrade available)
- Bartender-side: 20 gauge 300 series stainless steel
- Pre-assembled and shipped in sections up to 8 ft. for easy install
- Bartender-side panels removable for drain access
- We recommend customer-side panels are built by millworker to be removable for easy service
- Sealed-to-floor design prevents seepage
- Built-in chaseways conceals all plumbing, electric, soda & beer lines
- Completely assembled and mounted to bar die in factory to ensure layout accuracy
- Exclusive to Royal Series Underbar
- Engineered to exact dimensions
- Millwork panels and bar top can be prefabricated to save time during installation
- Supports 1,000 pounds per foot of downward force
- Built-in junction box (quantity & location to be verified by customer)
- Front panels (by millwork) easily removed for access to soda, beer, electrical and plumbing lines for future service or repair

### Modular Bar Die Chaseways

Chaseways allow for easy installation and access to beer, water, electrical, plumbing and other utility lines.

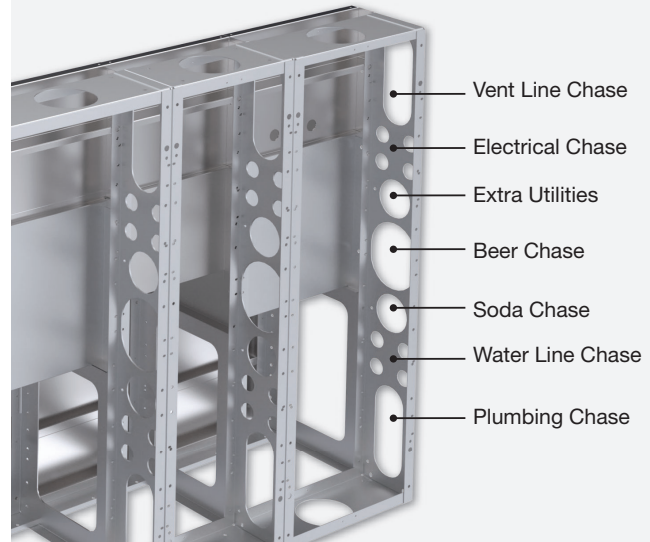

### Cabinet (Side View)

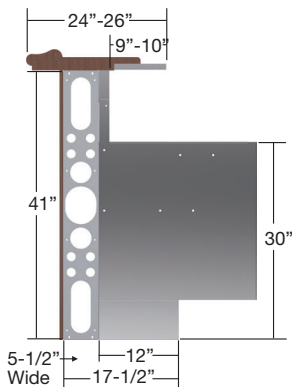

### Ice Bin (Side View)

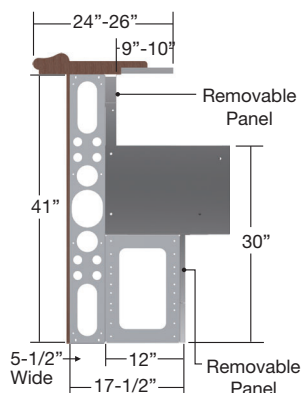

### Options

- Fully customizable angles, fillers & overall shape
- Dedicated enlarged cutouts for floor drains when specified

### California Prop 65 Warning:

This product can expose you to chemicals including lead and lead compounds, which are known to the State of California to cause cancer and birth defects or other reproductive harm. For more information go to [www.P65Warnings.ca.gov](http://www.P65Warnings.ca.gov).

