

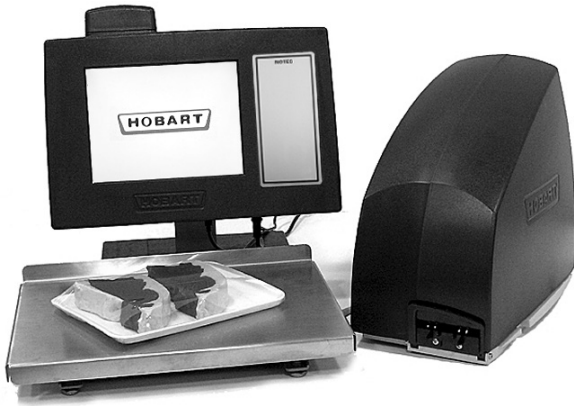

Project \_\_\_\_\_  
 AIA # \_\_\_\_\_ SIS # \_\_\_\_\_  
 Item # \_\_\_\_\_ Quantity \_\_\_\_\_ C.S.I. Section 114000



## Access Prepack System



Stand-Alone



### SPECIFIER STATEMENT

Access Prepack Systems consist of stand-alone scales, consoles and printers commonly used on Hobart's AWS, CLAS and Hand Wrap Stations.

### MODELS

- EPP-3** Access Prepack printer without low speed modnet
- EPCP-5i** Linux operating system, HT-Series scale functionality; Ethernet wired and wireless standard; Wireless enables WEP, PEAP, WPA, WPA2
- EPSA-1** Stand alone scale, 50 lb.
- EPSA-2** Stand alone scale, 30 lb.

### STANDARD FEATURES

#### Operator Mode

- + Large color touch screen display (all models 10")
- + 3-screen gesturing
- + Search database by description or nearest PLU number
- + Product and shelf life by day and/or hour
- + Operator notes and product notes
- + Onscreen help questions and answers
- + Pop-up alphanumeric keyboard/numeric keypad

#### Supervisor Mode

- + USB port can support external keyboard and USB drive
- + COOL records can be created on the scale
- + Database can be backed up to USB drive

### ACCESSORIES (Available at extra cost)

- ACCESS-HWSKIT – Hand Wrap Station Kit
- ACCESS-SAKIT – Stand Alone Kit

#### Wireless Accessory –

- EPCP-5i – wired and wireless are standard, no additional accessories are needed

ACCESS PREPACK SYSTEM

Approved by \_\_\_\_\_ Date \_\_\_\_\_ Approved by \_\_\_\_\_ Date \_\_\_\_\_

### HARDWARE

- + Dual-core processor
- + Standard laptop RAM, 1 GB of memory
- + 8 GB micro SD card
- + Battery backup for date and time
- + 1 USB port to support a USB drive or external keyboard for easy data entry

### SOFTWARE

- + Linux Operating System

### MERCHANDISING

- + 8 dot/mm high resolution printhead
- + Product life and shelf life can be managed by days and/or by hours
- + Operator and Product notes
- + Expanded text and special message fields have longer length, limited only by label size
- + EAN13 Bar Code available for packages over \$99.99 total price
- + 1½", 2¼" and 3" wide labels up to 4" length for auto-apply



**Fully Automatic AWS**

### SERVICEABILITY

- + Every operator/supervisor screen is a web page that can be accessed remotely via web browser
- + Diagnostics information can be retrieved; scale configuration and PLU database can be verified or modified
- + Monitor real-time use of the scale
- + System firmware can be upgraded via a USB drive or network
- + Automatically send emails when the system is out of labels or when the cassette/print head is disengaged for a given period of time
- + Onscreen help questions and answers
- + EPCP-5i uses HTe for remote scale access

### SPECIFICATIONS

**Access EPP Printer:** 120/60/1, 1.25 Amps, 150 Watts; 26.05 lbs. shipping weight

**Access EPCP Control Panel:** 120/60/1, .50 Amps, 65 Watts; 15.9 lbs. shipping weight

#### Weigher Capacity:

- For HWS, weighing capacities are 30 lb. x .01 lb. (30.09 maximum) or 50 lb. x .01 lb. (50.09 maximum) for all console models
- CLAS weigher has 30 lb. x .01 lb. (30.09 maximum) for all console models
- AWS/EWS weigher has 12 lb. x .005 lb., 30 lb. x .01 lb. capacity with EPCP-5i model

**Pricing Capacity:** Up to 999.99 in steps of .01



Fully Automatic AWS



Hand Wrap Station HWS

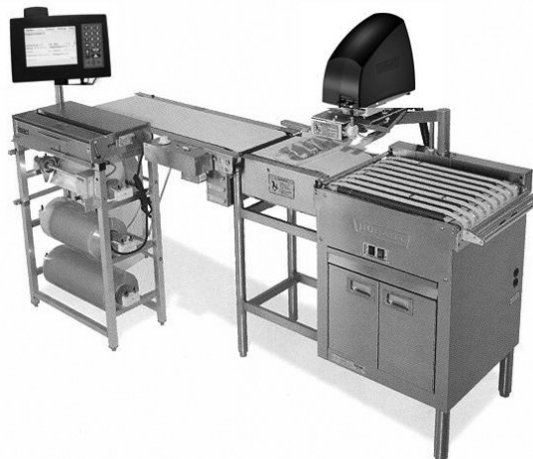

Semi-Automatic CLA System

### DETAILS AND DIMENSIONS

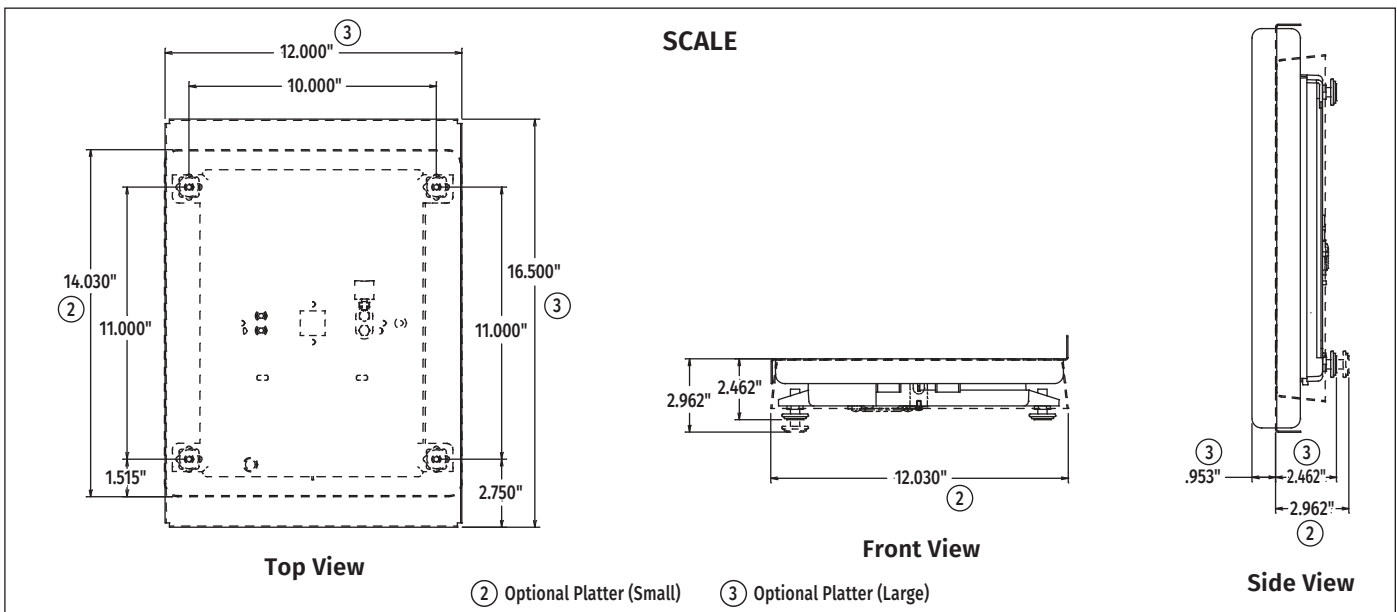
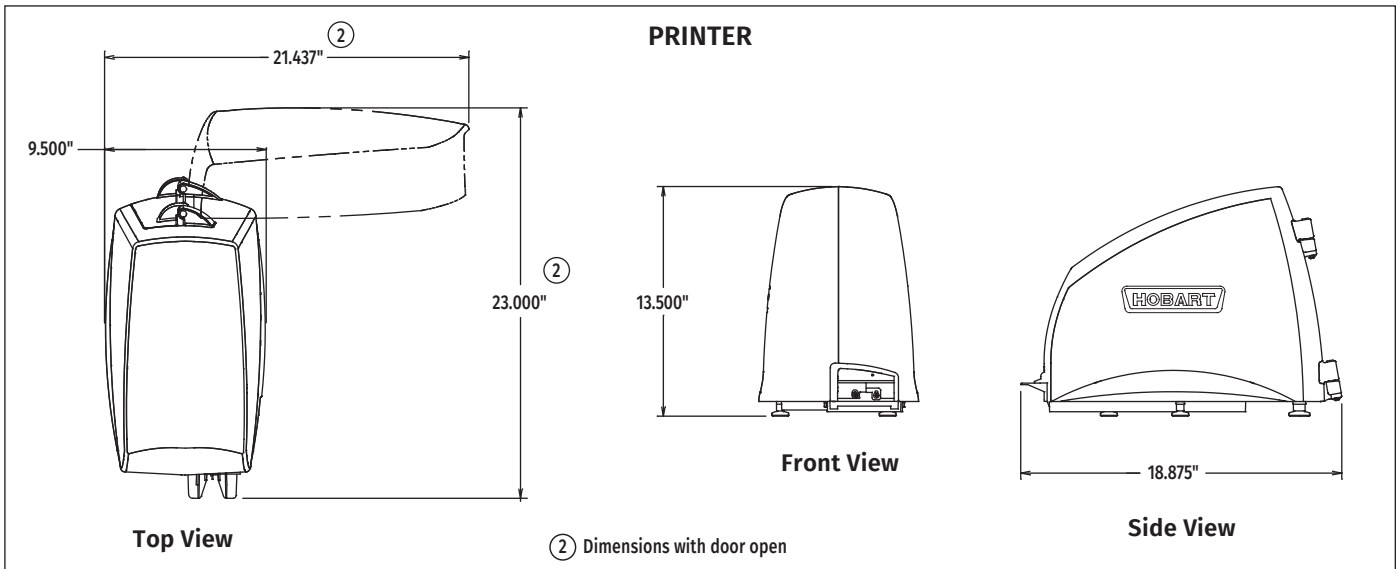
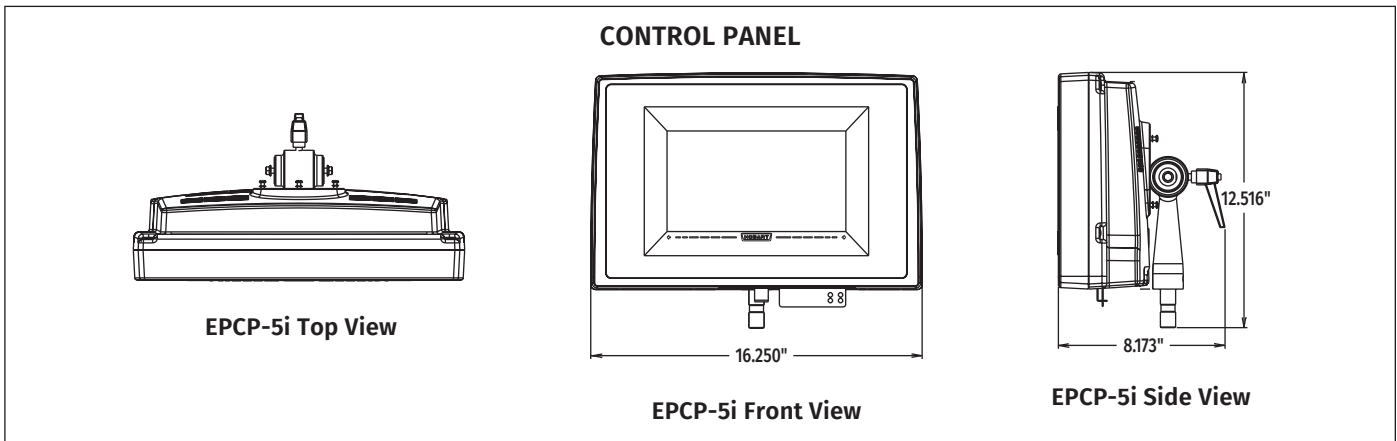

As continued product improvement is a policy of Hobart, specifications are subject to change without notice.