

## "ST6R5-GBK" STAINLESS STEEL TOP WORK TABLES

### 16GA Top w/5" Riser & Galvanized Legs & Adjustable Bracing

#### FEATURES:

- 16GA Stainless Steel Top w/5" Riser & Turndown
- Type 300 Stainless Steel With #4 Polish, Satin Finish
- Top Is Sound Deadened
- Reinforced With 1"x2" Channel Running Entire Length Of Table
- 1-1/2" Stallion Edge On Front Side Edges 90 Degree Bend Down For Table Line-Up
- Galvanized Base With Adjustable Bracing
- Shipped Knocked-Down, Easy-To-Assemble

#### SPECIFICATIONS:

- Top: Stainless Steel Tops Are TIG Welded, Exposed Welds Are Polished To Match Adjacent Surface
- Top: 16GA Stainless Steel Type 300 Stainless Steel With #4 Polish, Satin Finish
- Bracing: 1-1/4" Round O.D. 18GA Galvanized Steel
- Legs: 1-5/8" Round O.D. 16GA Tubular Galvanized Steel
- Gussets: Galvanized Steel
- Feet: 1" Adjustable Stainless Steel Bullet Feet

#### CERTIFICATIONS:



ST6R5-3048GBK

### ACCESSORIES

#### DESCRIPTION

- Drawer
- Drawer Lock
- Casters
- Overshelves
- Sinks
- Pot Rack

### "ST6R5-GBK" STAINLESS STEEL TOP WORK TABLES

LENGTH	24" WIDE	WT	WT CAP	30" WIDE	WT	WT CAP	36" WIDE	WT	WT CAP
24"	ST6R5-2424GBK	40	900	ST6R5-3024GBK	44	900	ST6R5-3624GBK	50	900
30"	ST6R5-2430GBK	44	900	ST6R5-3030GBK	48	900	ST6R5-3630GBK	56	900
36"	ST6R5-2436GBK	49	900	ST6R5-3036GBK	54	900	ST6R5-3636GBK	61	900
48"	ST6R5-2448GBK	58	900	ST6R5-3048GBK	65	900	ST6R5-3648GBK	73	900
60"	ST6R5-2460GBK	68	610	ST6R5-3060GBK	75	610	ST6R5-3660GBK	84	610
72"	ST6R5-2472GBK	77	400	ST6R5-3072GBK	85	400	ST6R5-3672GBK	96	400
84"	ST6R5-2484GBK	94	1350	ST6R5-3084GBK	105	1350	ST6R5-3684GBK	121	1350
96"	ST6R5-2496GBK	103	1350	ST6R5-3096GBK	116	1350	ST6R5-3696GBK	133	1350
108"	ST6R5-24108GBK	112	1350	ST6R5-30108GBK	125	1350	ST6R5-36108GBK	142	1350
120"	ST6R5-24120GBK	122	1130	ST6R5-30120GBK	136	1130	ST6R5-36120GBK	154	1130
132"	ST6R5-24132GBK	131	900	ST6R5-30132GBK	146	900	ST6R5-36132GBK	165	900
144"	ST6R5-24144GBK	141	680	ST6R5-30144GBK	158	680	ST6R5-36144GBK	179	680

OVERALL WEIGHT (WT) AND MAX WEIGHT CAPACITY (WT CAP) ARE IN POUNDS (LBS). MAX WEIGHT CAPACITY EVENLY DISTRIBUTED. ALL DIMENSIONS ARE TYPICAL. TOLERANCE +/- .500". JOHN BOOS & CO. RESERVES THE RIGHT TO CHANGE SPECIFICATIONS WITHOUT NOTICE.

# DETAILED SPECIFICATIONS

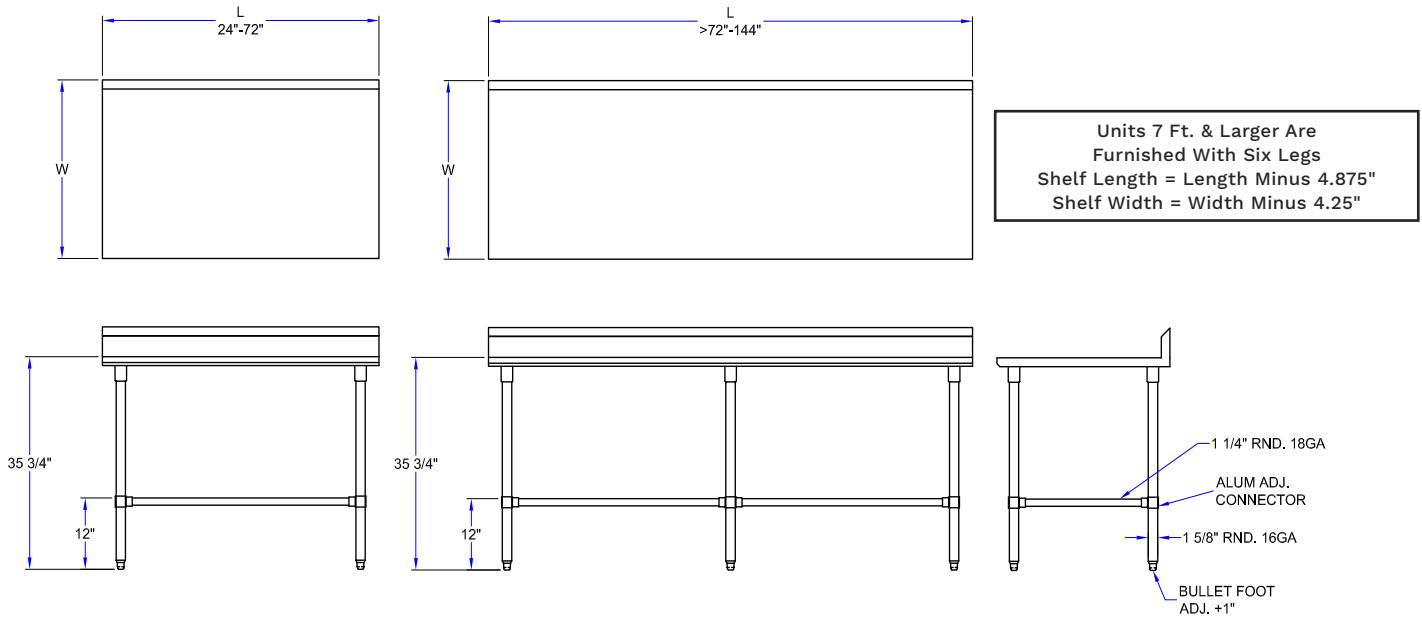

## MODEL # STRUCTURE



### "ST6R5-GBK" STAINLESS STEEL TOP WORK TABLES

LENGTH	24" WIDE	WT	WT CAP	30" WIDE	WT	WT CAP	36" WIDE	WT	WT CAP
24"	ST6R5-2424GBK	40	900	ST6R5-3024GBK	44	900	ST6R5-3624GBK	50	900
30"	ST6R5-2430GBK	44	900	ST6R5-3030GBK	48	900	ST6R5-3630GBK	56	900
36"	ST6R5-2436GBK	49	900	ST6R5-3036GBK	54	900	ST6R5-3636GBK	61	900
48"	ST6R5-2448GBK	58	900	ST6R5-3048GBK	65	900	ST6R5-3648GBK	73	900
60"	ST6R5-2460GBK	68	610	ST6R5-3060GBK	75	610	ST6R5-3660GBK	84	610
72"	ST6R5-2472GBK	77	400	ST6R5-3072GBK	85	400	ST6R5-3672GBK	96	400
84"	ST6R5-2484GBK	94	1350	ST6R5-3084GBK	105	1350	ST6R5-3684GBK	121	1350
96"	ST6R5-2496GBK	103	1350	ST6R5-3096GBK	116	1350	ST6R5-3696GBK	133	1350
108"	ST6R5-24108GBK	112	1350	ST6R5-30108GBK	125	1350	ST6R5-36108GBK	142	1350
120"	ST6R5-24120GBK	122	1130	ST6R5-30120GBK	136	1130	ST6R5-36120GBK	154	1130
132"	ST6R5-24132GBK	131	900	ST6R5-30132GBK	146	900	ST6R5-36132GBK	165	900
144"	ST6R5-24144GBK	141	680	ST6R5-30144GBK	158	680	ST6R5-36144GBK	179	680

OVERALL WEIGHT (WT) AND MAX WEIGHT CAPACITY (WT CAP) ARE IN POUNDS (LBS). MAX WEIGHT CAPACITY EVENLY DISTRIBUTED. ALL DIMENSIONS ARE TYPICAL. TOLERANCE +/- .500". JOHN BOOS & CO. RESERVES THE RIGHT TO CHANGE SPECIFICATIONS WITHOUT NOTICE.