

F1FL36 with stainless doors and top



Capable of storing specialty cocktail ice



Intertek Intertek
 4004503
 Conforms to NSF/ANSI STD 7 and UL STD 471
 Certified to CSA STD C22.2 No. 120

Standard Features

- Self-contained
- Stainless steel interior
- Locking door(s)
- LED interior lighting
- Two defrost cycles
- Automatic condensate evaporator
- Heated cabinet front to minimize condensation
- Three adjustable, coated-wire shelves

Project: _____	AIA# _____
Item #: _____ Qty: _____	SIS# _____
Model #: _____	

Frosters, One Zone, Front Serviced, Low Profile	
F1FL	F1FL32, F1FL36



Configurable Options

Refrigeration Compartment

Location:

- Left or Right

Refrigeration Compartment

Cover Finish:

- Black vinyl-clad
- Stainless steel
- Jeweled stainless
- Laminated
- Unlaminated

Door Style & Finish:

- Black vinyl-clad
- Stainless steel
- Jeweled stainless
- Laminated
- Unlaminated
- Glass, black vinyl-clad
- Glass, stainless steel
- Glass, jeweled stainless
- Glass, laminated

Door Hinge Location

- Left or Right

Door Handle:

- Signature
- Pull-tab
- Tube

Top Style:

- No finished top
- Stainless top
- Drainboard top

Left and Right Side Finish:

- Black vinyl-clad
- Stainless steel

Back Finish:

- Galvanized steel
- Stainless steel

LED Lighting Style:

- Bright white (7,000k)
- Warm white (3,500k)
- Amber (2,700k)
- Blue

Glastender, Inc. • 5400 N Michigan Rd • Saginaw, MI • 48604-9780 989.752.4275 • 800.748.0423 • Fax 989.752.4444 www.glastender.com	Approval/Notes:
<small>Specifications subject to change without notice. For current specifications please visit our website.</small>	

Frosters - One Zone, Front Serviced, Low Profile

Specifications

		F1FL32	F1FL36
Dimensions	Length	32"	36"
	Number of Sections	1	1
	Door Opening	16"	20"
Electrical	Electrical Supply	120V, 1 phase, 60 Hz, dedicated 15A circuit required	
	Full Load Amps	6.5	
	Plug Type	8 foot NEMA 5-15P grounded cord and plug which exits the back of refrigeration compartment	
Refrigeration	Refrigerant	R290 refrigerant - 130 grams, 4.59 oz, 0.29 pounds	
	Compressor	Reciprocating, 1/3 HP, 1300 BTUH, 0.11 Tons	
	Heat Rejection	2660 BTUH	
Operating Range		12°F (-11°C) to 35°F (2°C)	
Plumbing		Automatic condensate evaporator. No drain connection required †	
Weight Bearing Capacity		Countertops and other accessories should not exceed 500 pounds per door	

Materials

- Stainless steel parts include: exterior sub-top, interior, front of cabinet, hinges, hinge and lock brackets, and optional legs
- Black vinyl-clad steel parts include: standard sides, doors and compressor cover
- Galvanized steel parts include: back and bottom
- Zinc plated CR steel parts include: leg sockets

Refrigeration

- Fin & tube evaporator with forced air circulation
- Equipped with manual fast freeze mode that accelerates the freezing process and automatically reverts back to the normal operating mode

Plumbing

- Optional drainboard top 1/2" ID drain line stubs out beneath the compressor compartment; field connection required



† Building conditions outside the guidelines of ASHRAE 55 and ASHRE 62.1 may need to be plumbed to a drain.

Capacities

	F1FL32	F1FL36
10 oz. Mugs	90	126
6" High Pint Glasses	72	90

Frosters - One Zone, Front Serviced, Low Profile

Drawings

PLAN VIEWS

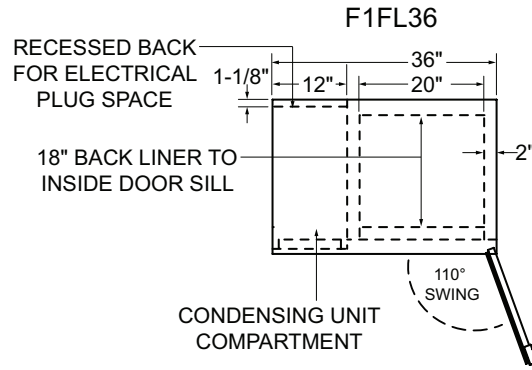
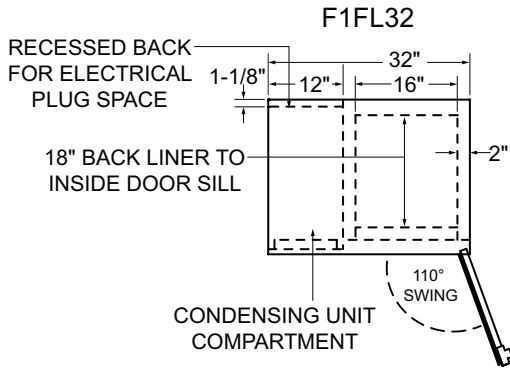

SIDE VIEWS

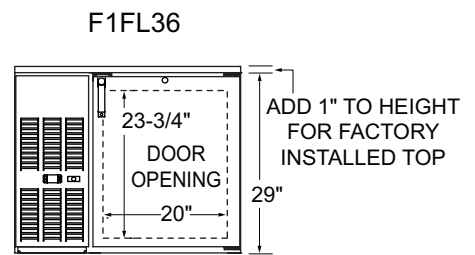
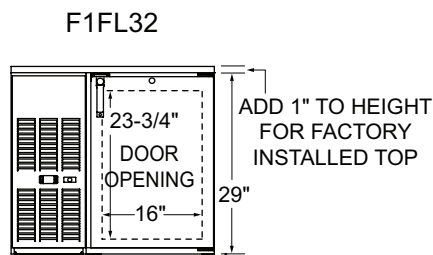

FRONT VIEWS

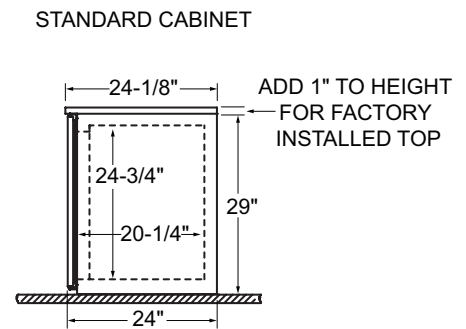
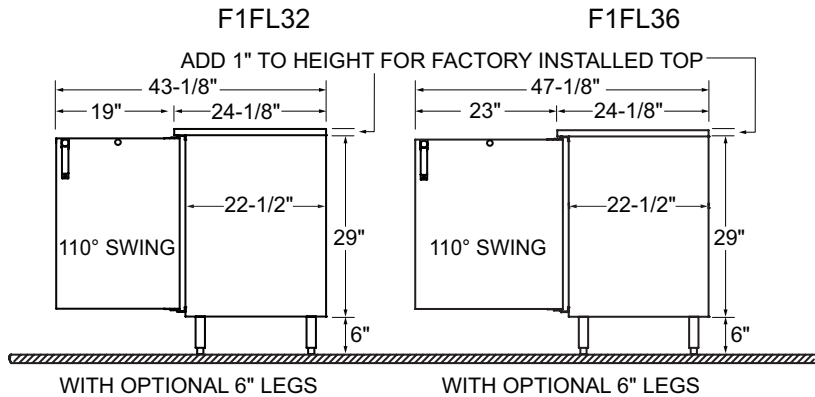

OPTIONAL LEGS AND CASTERS

