

# Direct Steam Kettle

2/3 Jacketed, Tilting  
Deep Drawn Construction  
Wall-Console Mounted  
Made in USA

# Model TWWC

## STANDARD FEATURES

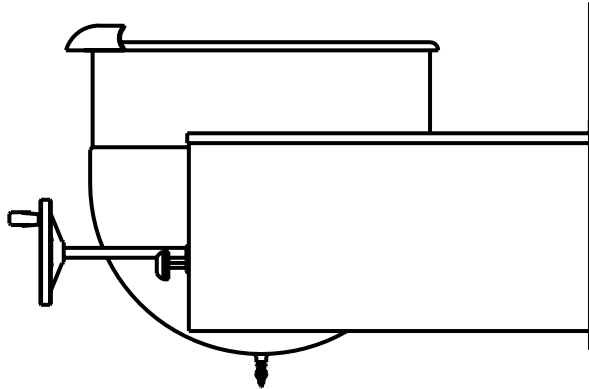

- ◆ Kettle System
  - ◇ Seamless deep-drawn 304 kettle liner
- ◆ 304L seamless deep-drawn stainless kettle jacket
- ◆ 304 stainless reinforced console boxes
- ◆ Self-locking worm gear tilt mechanism
- ◆ Connection plumbing parts installed in console with rear connection
- ◆ 30 psi operating pressure

## Model TWWC

Legion equipment is built to comply with applicable standards for manufacturers. Approval agencies may include ASME, NSF, UL, ETL, AGA, CSA, CGA, and others. Legion reserves the right of design improvement or modification as warranted.

### Models and Capacities

TWWC-20	20 gal.	76 l.
TWWC-30	30 gal.	114 l.
TWWC-40	40 gal.	151 l.
TWWC-50	50 gal.	189 l.
TWWC-60	60 gal.	227 l.
TWWC-80	80 gal.	303 l.
TWWC-100	100 gal.	379 l.

Select draw-off valve:  2"  3"

With:  compression  ball type fitting

See price list for other draw-off options.

### Optional Features and Accessories

See price list for supplemental information regarding options

#### Faucet Options:

- Single or double fill faucet with bracket & 12" or 18" swing nozzle
- 48" flexible spray hose assembly (vinyl or stainless) for use with dual or single fill faucet
- Faucet bracket
- Automatic water filling meter

(Call for information regarding additional faucet options)

#### Prison/Security Options:

- Fastener (nut for draw-off)
- Draw-off nut driver tool
- Lockable lid
- Draw-off protection
- Reinforced bar rim

#### Other Options:

- Higher operating pressure
- Air eliminator valve
- Pressure reducing valve
- Connection plumbing parts kit
- Mixer/Agitator, 2 speed
- Lift-off cover
- 1 piece actuator-assisted cover,
- In-wall carrier for wall mounting

#### Accessories:

- Single basket insert, 20 - 40 gallon
- Tri-basket insert
- Nylon bag insert with spreader ring
- Pour lip pan holder assembly
- Measuring strip
- Kettle care kit

Revision 113



**LEGION** Legion Industries, Inc. P.O. Office Box 728 Waynesboro, GA 30830 (800) 887-1988  
(706) 554-4411 Fax: (706) 554-2035 www.legionindustries.com sales@legionindustries.com

# Model TWWC

2/3 Jacketed, Tilting  
Deep Drawn Construction  
Wall-Console Mounted  
Made in USA

# Direct Steam Kettle

DRAWING REPRESENTS MODEL TWWC-40 WITH OPTIONAL 1 1/2 DRAW-OFF

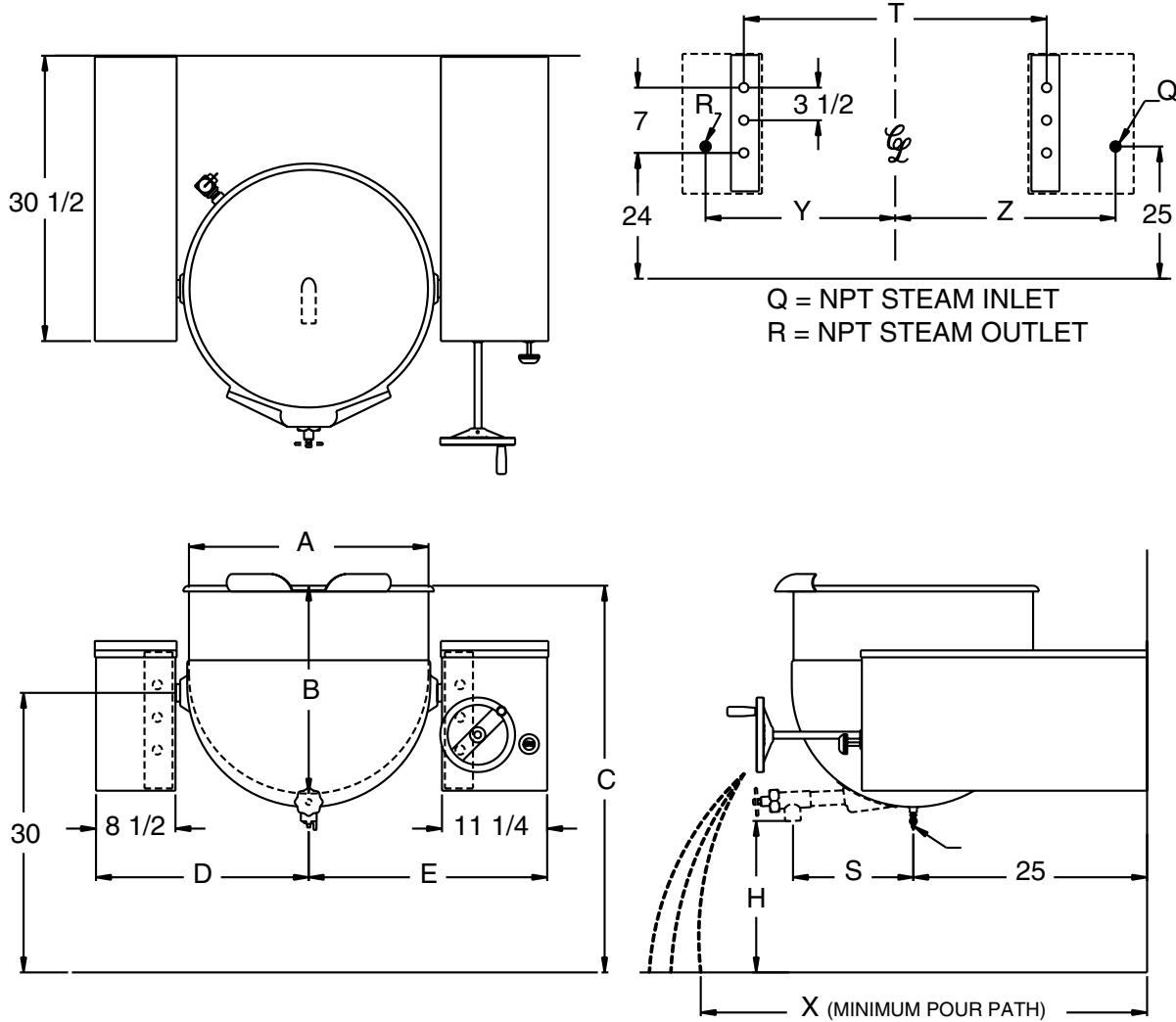

MODEL TWWC DIMENSIONS													
GAL.	A	B	C	D	E	H*	Q	R	S	T	X	Y	Z
20	22.0	16.0	39.0	20.6	23.4	20.0	.75	.50	13.0	28.0	33.0	18.1	21.5
30	23.0	20.3	41.3	21.5	24.3	18.0	.75	.50	13.0	29.8	35.3	19.0	22.4
40	25.5	22.3	41.5	22.9	25.6	16.3	.75	.50	13.0	32.5	35.5	20.4	23.8
50	29.5	21.8	38.3	25.1	27.9	13.5	.75	.50	14.0	36.9	32.3	22.6	26.0
60	29.5	25.0	41.5	25.1	27.9	13.5	.75	.50	14.0	36.9	35.5	22.6	26.0
80	32.5	27.6	43.4	26.5	29.3	12.8	.75	.75	14.0	39.6	37.4	24.3	27.4
100	39.0	25.9	41.3	28.9	31.9	12.4	.75	.75	17.8	44.5	35.4	27.0	29.8

\*"H" dimension varies with draw-off size selection.

Revised 113



**LEGION** Legion Industries, Inc. P.O. Office Box 728 Waynesboro, GA 30830 (800) 887-1988  
(706) 554-4411 Fax: (706) 554-2035 www.legionindustries.com sales@legionindustries.com