

COOLER 900951A040404P
 46X82.25DS 34X78DR LH FLT CLR
 DOOR FRAME=GL/GL DOOR PLUG=GL/GL
 115/60/1 - 1.0 AMPS

Print Used As Worksheet Only
 Not a Control document
 Valid 10 Days Before or 10 Days
 After Scheduled Production Date

QTY DESCRIPTION

1 ----- 900951A040404P ----- 34" X 78" L DOOR ASSEMBLY

- COOLER DOOR - SMALL PARTS BOX**
- 8 ----- 791567 ----- 3/8" NYLON BOLT
 - 16----- 247451075 ----- 3/8" NYLON NUTS
 - 16----- 1562 ----- 3/8" NYLON WASHERS
 - 1----- 282461075 ----- GRAY SILICONE
 - 1---- 500000133 DIAL THEM. (SHIP LOOSE)
 - 5----- 189161075 ----- CLIP THEM.
 - 5----- 266678803 ----- SCREWS #10X3/4"

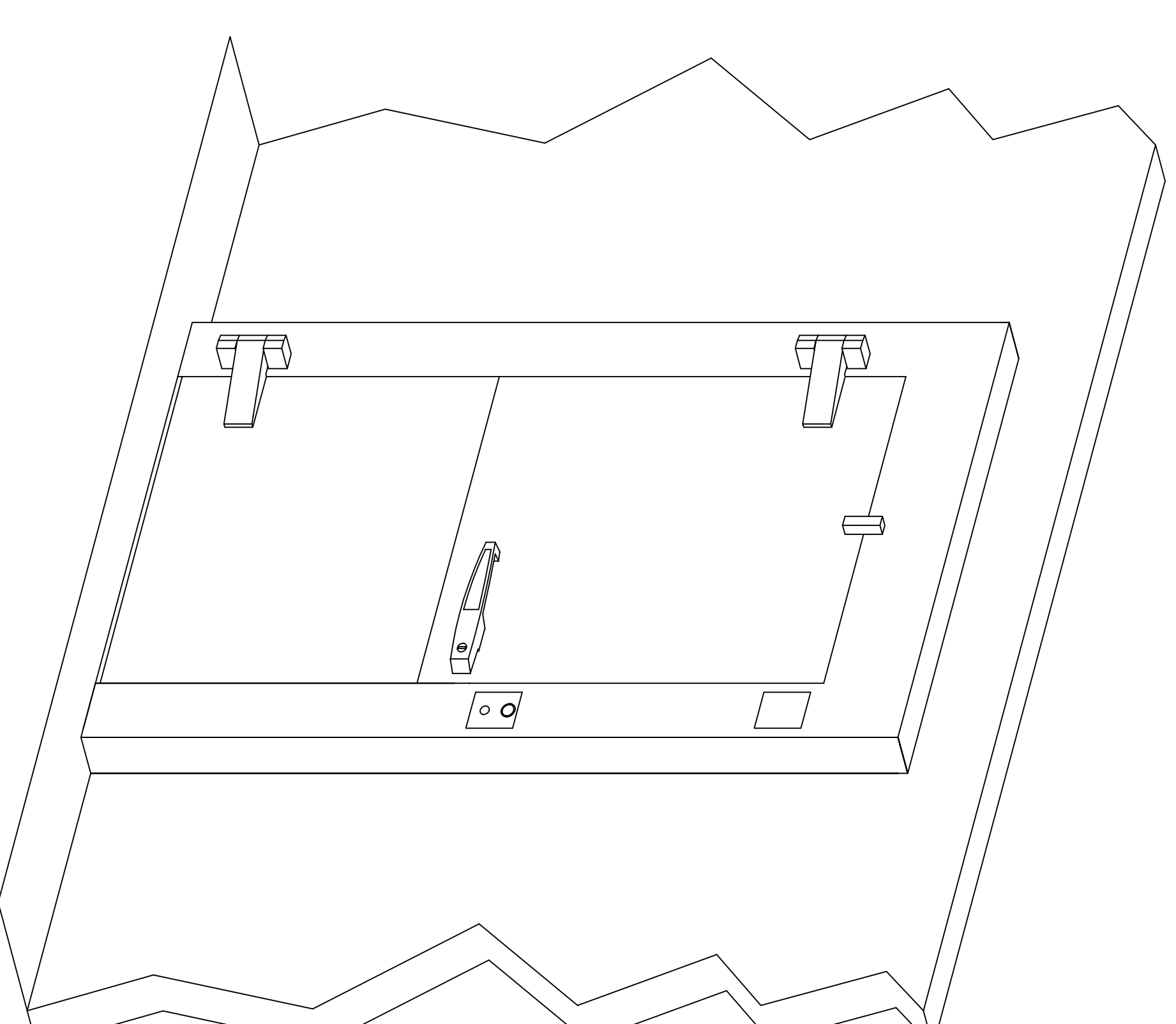

ORDER# _____

SYM	REVISION	BY	DATE

DRAWING NO. 900951	DRAWN: DSB	CUSTOMER: COOLER BOLT/DOOR DOOR SECTION
2915 TENNESSEE AVENUE NORTH P.O. BOX 550 PARSONS, TN. 38363 (731) 847-6361	CHECKED: DC/DT	PROJECT: BOLT/DOOR DOOR LH (NO SILL)
DATE: 5/30/17	SCALE: 3/8"=1'-0"	SHEET: 1 OF 1

