



DCM-752/751B_H

SANITARY CUBELET ICE MACHINE/DISPENSER



DCM-752/751B_H
07/02/24
Item # 13290

Item #: _____
Project: _____
Qty: _____
AIA#: _____

W x D x H
34^{1/16}" x 28^{1/2}" x 48^{1/16}"

SD-750
34" x 28" x 32^{3/4}"

Ice Machine Shipping Dimensions
39^{3/4}" x 32^{1/2}" x 53^{1/2}"

DCM-752BAH
Air-Cooled
Shown with optional
SD-750 Stand

DCM-751BWH
Water-Cooled



Features

- ▶ Durable stainless steel exterior
- ▶ Advanced CleanCycle24™ design 
- ▶ Stainless steel auger with greaseless bearing

- Up to 782 lbs. of ice production per 24 hours
- Built-in storage capacity of 3.2ft³/95 lbs.*
- 2 second flush cycle every hour
- Easy to chew, Cubelet ice
- Self-contained design reducing opportunities for cross contamination
- Flush cycle removes sediment for cleaner ice
- Removable air filters (air-cooled model only)
- Dispenses ice and water
- R-404A Refrigerant

Warranty:

3 Year Parts & Labor on entire machine.
5 Year Parts on Compressor; air-cooled condenser coil.
Valid in United States, Canada, Puerto Rico and U.S. Territories. Contact factory for warranty in other countries.
*Rated in accordance with AHRI Standard 820(I-P). Capacity based on 100% of total volume x 30 lb/ft³ average density of ice.



ICE PRODUCTION WATER USAGE ELECTRICAL

Condenser	Model	Air / Water Temp Lbs. per 24 hours		Potable Gal. per 100 lbs.	Condenser Gal. per 100 lbs.	kWh Used per 100 lbs.	Min. Circuit/Max. Fuse Size	Amperage	Voltage	Circuit Wires (including ground)	Heat Rejection BTU/hr.	Refrigerant Charge Amount	Net / Ship Weight (lbs.)
		70°/50°F	90°/70°F	90°/70°F	90°/70°F	90°/70°F							
Air-Cooled	DCM-752BAH	708	576	12.0	N/A	5.10	20A	13A	115V/60/1	3	6,900	1 lb. 10 oz.	300 / 345
Water-Cooled	DCM-751BWH	782	678	12.0	96	4.76	20A	18.9A	115V/60/1	3	7,600	1 lb. 6 oz.	300 / 345

Cubelet Dimensions*

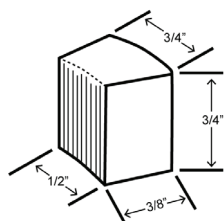

* approximate size in inches, image not to scale

Operating Limits

- Ambient Temp Range 45 - 100°F
- Water Temp Range 45 - 90°F
- Water Pressure 10 - 113 PSIG
- Voltage Range 104 - 127V
- If GFCI is required, a GFCI breaker MUST be used in lieu of GFCI receptacle

Service

- Allow 6" (15 cm) clearance at rear and sides for proper air circulation and ease of maintenance/ service should they be required. Allow 24" (61 cm) clearance at top to allow for removal of the auger.

Plumbing

- Icemaker Water Supply Line: Min. 1/4" Nominal ID Copper Water Tubing or Equivalent
- Icemaker Drain Line: Min. 3/4" Nominal ID Hard Pipe or Equivalent Water-Cooled Model (Lines Must Be Independent of Icemaker)
- Condenser Water Supply Line: Min. 1/4" Nominal ID Copper Water Tubing or Equivalent
- Condenser Drain/Return Line: Min. 1/4" Nominal ID Hard Pipe (open drain system) or Copper Water Tubing (closed loop system) or Equivalent

Water Filter

Please refer to water filter specification sheet for recommendations.

Hoshizaki reserves the right to change specifications without notice.



DCM-752/751B_H

SANITARY CUBELET ICE MACHINE/DISPENSER



DCM-752/751B_H
07/02/24
Item # 13290

FRONT VIEW

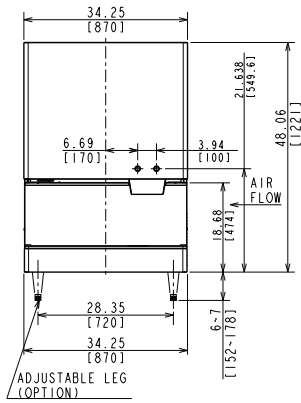

DCM-752BAH AIR-COOLED

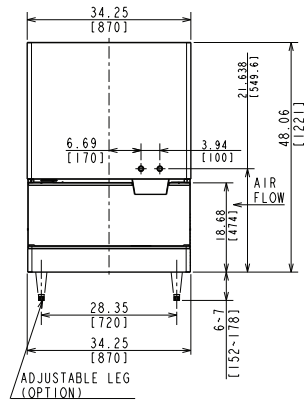

DCM-751BWH WATER-COOLED

inch
[mm]

SIDE VIEW

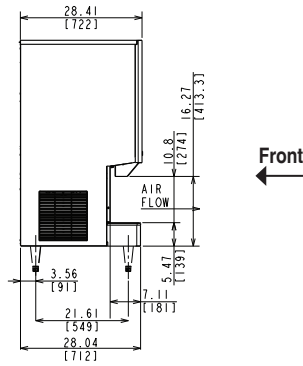

DCM-752BAH AIR-COOLED

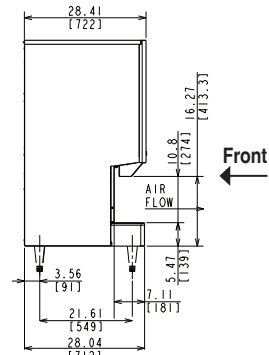

DCM-751BWH WATER-COOLED

REAR VIEW

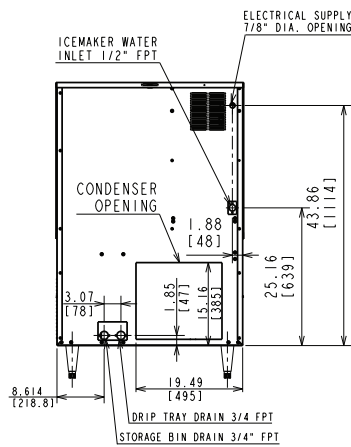

DCM-752BAH AIR-COOLED

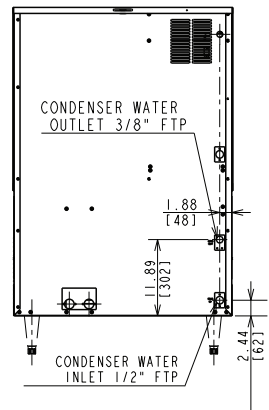

DCM-751BWH WATER-COOLED

TOP VIEW

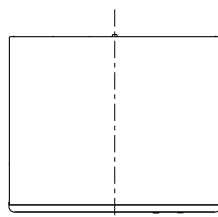

DCM-752BAH AIR-COOLED

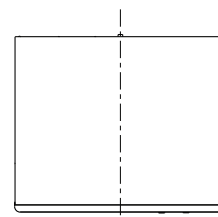

DCM-751BWH WATER-COOLED