



ATLAS METAL

1135 N.W. 159th DRIVE, MIAMI, FLORIDA 33169

TEL 305.625.2451

TOLL FREE 800.762.7565

FAX 305.623.0475

WWW.ATLASFOODSERV.COM

SALES@ATLASFOODSERV.COM

Project: _____

Item No.: _____

Quantity: _____

DROP-IN SERVING EQUIPMENT



DISPLAY CASE

Refrigerated,
Pass-Through
Self-Contained

WCPT-3

WCPT-4

SPECIFICATIONS

TOP: Constructed of 18 gauge, type 304 stainless steel, die stamped with a raised perimeter bead. The top is solid, full-length, to support the refrigerated display case. There shall be a solid vinyl gasket under the beaded edge to form a seal to the counter top, thus preventing seepage or marring of the counter top.

DISPLAY CASE: Double wall constructed of type 304 stainless steel - 20 gauge, both interior and exterior, and filled with 2" of foamed-in-place polyurethane insulation. Customer's side and operator's side are provided with a set of two (2) sliding, self-closing, thermo-pane, insulated glass doors. The doors are removable for ease of cleaning. The display case is provided with two (2) plastic coated wire shelves, adjustable on 1" increments, and two (2) sets of fluorescent light fixtures mounted behind plastic guards which are recessed into the side panels. The light fixtures are provided with a separate on/off switch. An internal thermometer is provided.

REFRIGERATION SYSTEM: The compressor housing shall be fabricated from 14 gauge galvanized and bolted to the base of the unit. A fully self-contained condensing unit is provided with a hermetically sealed compressor and a thermostat control. The system is also provided with a forced air evaporator, for even temperature throughout the display case, which drains into a condensate evaporator, pre-wired in the unit. The system is fully charged with CFC free refrigerant and ready to operate.

NOTE: Proper ventilation must be provided in counter.

ELECTRICAL: The unit will be wired for 15 amps., 120 volt, single phase operation with an on/off thermostat switch and pilot light. A 6' long, 3-wire cord and plug (NEMA 5-15P) will be provided.

Specifications subject to change without notice.

STANDARD FEATURES

- Large, lighted display area with adjustable shelves - it's the ideal merchandiser
- Sliding glass doors on customer's and operator's side, making loading and self-service move quickly
- Forced air evaporator blower system for maximum efficiency in cooling
- Factory applied gasket - makes installation a snap and seals units to the counter top, thus eliminating seepage
- 1-Year Parts & Labor Warranty
- UL Listed

ACCESSORIES

- 5YW - 5-Year Compressor Warranty
- Door Locking Device (2 required)
- Extra Shelf
- Plastic Laminate Trim
- Sliding Doors with Reflective Tempered Vision Panel (bronze or gray)
- Solid (1) piece Tempered Reflective Vision Panel (bronze or gray)
- Solid Stainless Steel Back
- RS - Remote on/off switch for counter mounting
- RDVE - Rear Drain Valve Extension
- * 220 Volt - 50 Cycle Compressor

*Please see Operation & Installation Manual for ALL operation and maintenance details.

* Units with these accessories are not currently UL listed.

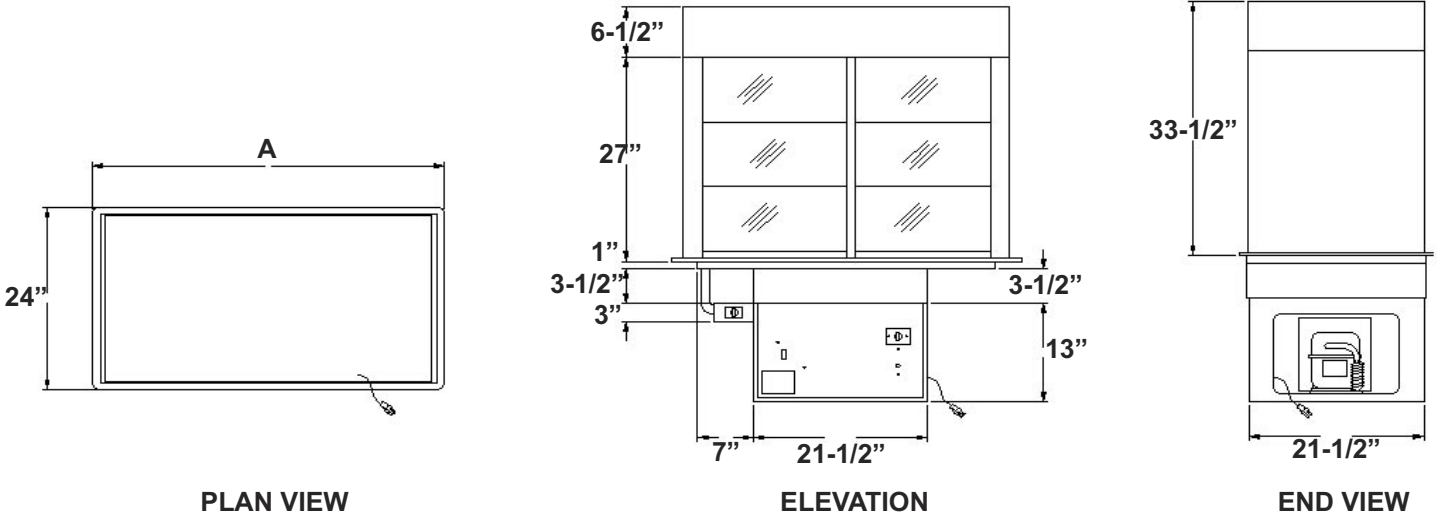

MODEL	"A"	ELECTRICAL CHARACTERISTICS	CUT-OUT REQUIRED (W X L)	SHIP WT. (LBS.)	CUBIC FEET
WCPT-3	43-1/2 (110.5cm)	11.0 amps. - 120V 1/2 HP	22-1/4" X 41-3/4" (56.5 X 106cm)	443 (200.9kg)	12 CU FT.
WCPT-4	57-1/4 (145.4cm)	11.0 amps. - 120V 1/2 HP	22-1/4" X 55-1/2" (56.5 X 141cm)	520 (247.7kg)	16 CU FT.

WCPTX - REFRIGERATED PASS-THROUGH WITHOUT COMPRESSOR

Units include Refrigerated Pass-Through, Thermostat, Cap Tube & Drier (for hook up in field by others)

COMPRESSORS FOR REMOTE INSTALLATIONS

1800-4212 - 1/2 HP for WCPTX-3 & 4