

COLDRINK[®]/INSURICE[®] TRIPLE MANIFOLD WITH 20" PREFILTER

FOR USE WITH EVERPURE QUICK-CHANGE CARTRIDGES

Coldrink/Insurice Triple Manifold with 20" Prefilter:
EV9293-23
EC210 Replacement Cartridge:
EV9534-26 (6 PK)



APPLICATIONS

- ◆ Fountain
- ◆ Coffee
- ◆ Ice
- ◆ Tea

FEATURES • BENEFITS

- ◆ Commercial-grade filter head for Everpure filter cartridges
- ◆ Includes mounting box bracket and screws for fast and easy installation. No extra mounting plate is required
- ◆ Modular design of box bracket allows for future retrofitting of add-on components without disassembly of system
- ◆ Optional built-in water shut-off valve and flushing valve makes cartridge change-outs easy
- ◆ Cartridge nesting feature provides a more secure, durable fit
- ◆ Built-in water pressure gauge helps monitor proper flow
- ◆ Engineered for durability, strength and longevity; will not corrode
- ◆ Includes Everpure EC210 pre-filter cartridge
- ◆ All wetted parts have successfully passed NSF[®] extraction tests

INSTALLATION TIPS

- ◆ Mounts directly onto flat surface.
- ◆ Install vertically so cartridge hangs down.
- ◆ Allow 2½" (6.4 cm) clearance below the cartridge for easy cartridge replacement.
- ◆ Flush filter by running water through filter according to cartridge instructions.
- ◆ Refer to Installation, Operation & Maintenance Manual for cartridge flushing and startup.

OPERATION TIPS

- ◆ Change cartridges on a regular six (6) month preventative maintenance program.
- ◆ Change cartridges when capacity is reached or when pressure decreases.

COLDRINK/INSURICE TRIPLE MANIFOLD WITH 20" PREFILTER

EV9293-23

Coldrink/Insurice Triple Manifold with 20" Prefilter:
EV9293-23
EC210 Replacement Cartridge:
EV9534-26 (6 PK)

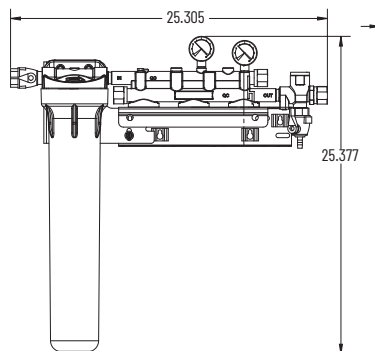

SPECIFICATIONS

- ◆ **Overall Dimensions**
25.31" W x 25.38" H x 6.13" D
(64.27 cm x 64.46 cm x 15.57 cm)
- ◆ **Inlet Connection**
3/4"
- ◆ **Outlet Connection**
3/4"
- ◆ **Rated Capacity**
Varies according to filter cartridge used
- ◆ **Electrical Connection**
None required
- ◆ **Shipping Weight**
17 lbs (7.7 kgs)

WARRANTY

Everpure water treatment systems by Pentair (excluding replaceable elements) are covered by a limited warranty against defects in material and workmanship for a period of five years after date of purchase. Everpure replaceable elements (filter cartridges and water treatment cartridges) are covered by a limited warranty against defects in material and workmanship for a period of one year after date of purchase. See printed warranty for details. Pentair will provide a copy of the warranty upon request.

The contaminants or other substances removed or reduced by this drinking water system are not necessarily in your water. Do not use with water that is microbiologically unsafe or of unknown quality without adequate disinfection before or after the system. Systems certified for cyst reduction may be used with disinfected water that may contain filterable cysts.

Since the conditions under which our products may be used are beyond our control, we cannot accept any liability with respect to the improper installation, application and/or use of our products.



World Headquarters
1040 Muirfield Drive
Hanover Park, IL 60133
United States
800.942.1153 (US Only)
630.307.3000 Main
cseverpure@pentair.com

Australia
1-21 Monash Drive
Dandenong South, Vic 3175
Australia
011.1300 576 190 Tel
au.everpure@pentair.com

China
21F Cloud 9 Plaza, NO 1118
Shanghai, 200052
China
86.21.3211.4588 Tel
china.water@pentair.com

India
Boulevard, B-9/A,
7th Floor - Tower B Sector 62
Noida - 201301
91.120.419.9444 Tel
indiacustomer@pentair.com

Europe
Pentair Water Belgium BVBA
Industriepark Wolfstee,
Toekomstlaan 30,
B-2200 Herentals
Belgium
+32.(0).14.283.504 Tel
sales@everpure-europe.com

Japan Inc.
Hashimoto MN Bldg. 7F,
3-25-1 Hashimoto, Midori-ku,
Sagamihara-shi
Kanagawa 252-0143
Japan
81.(0)42.775.3011 Tel
info@everpure.co.jp

Southeast Asia
390 Havelock Road,
#04-01 King's Centre
Singapore 169662
65.6768.5800 Tel
cseverpure@pentair.com

§ Pentair trademarks and logos are owned by Pentair plc or its affiliates. For a detailed list of where Pentair trademarks are registered, please visit www.pentair.com/en/registrations.html. Third party registered and unregistered trademarks and logos are the property of their respective owners. Because we are continuously improving our products and services, Pentair reserves the right to change specifications without prior notice. Pentair is an equal opportunity employer.

EV9293-23 N019 ©2019 Pentair Filtration Solutions, LLC. All Rights Reserved.