

Project: _____

Item: _____

Quantity: _____

Bulk Sheet Pan Dolly

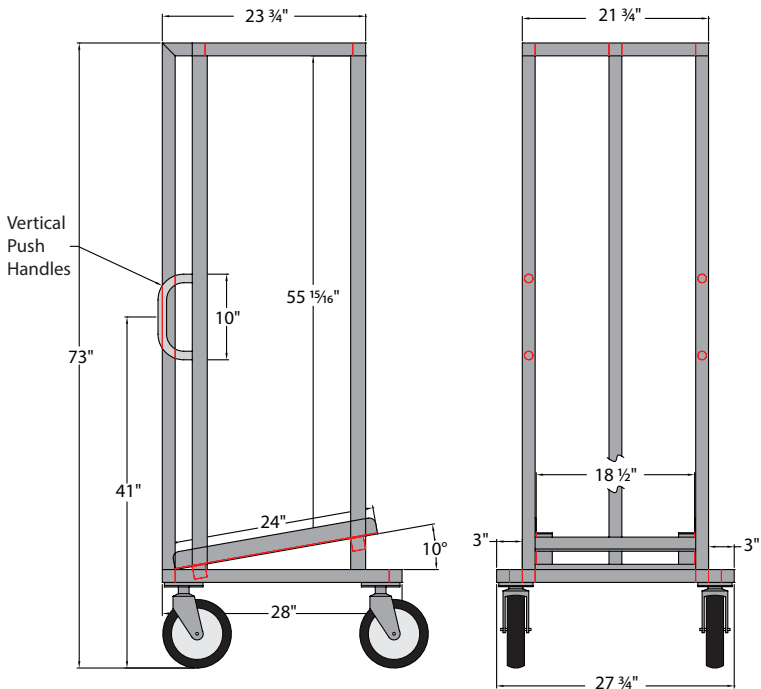

Originally designed for a hotel casino, these dollies have also been used in hospitals and correctional facilities.

One unit will store and transport up to 140 sheet pans. Purposely designed to hold sheet pans at a backward angle to keep the stack from tipping forward outside of the frame.

- Heavy duty caster mounting plates are welded to the rack for extra caster strength.
 - Four, $\frac{3}{8}$ thick, pre-tapped caster plates are welded to base frame to accept 8" x 2" polyurethane tread swivel platform casters.
- Overall Construction:
 - Frame consists of 1 1/2" sq. tube with .070 wall thickness, top and bottom frame, 1 1/2" x 1 3/4" tube with .070 wall thickness uprights.
 - Pans rest on a set of 2" x 2" angles with .125 wall thickness.
- Can be customized to meet your specific needs.
- Five Year Guarantee against material defects and workmanship.
- Lifetime Guarantee against rust and corrosion.

► Bulk Sheet Pan Dolly

Model No.	Size W-H-D	Pan Capacity	Ship Lbs.
50112	27 3/4" x 73" x 28 1/2"	140	68

Four 8" plate type swivel casters.

Accommodates 18" x 26" sheet pans.



New Age Industrial Corp., Inc. || NewAgeIndustrial.com || Made in the USA

PO Box 520 • 16788 US Hwy 36 • Norton, Kansas 67654 || Phone: (800) 255-0104 • (785) 877-5121 || Fax: (877)-877-7687 • (785) 877-2616

This information is for general sales and engineering use only. New Age Industrial reserves the right to modify or make changes at any time, without notice, to materials and specifications.