



Your Solutions Partner

Specifications

F.O.B. Sedalia, Missouri 65301



613-E3

OPTIONS:

- Stainless steel interior
- 27" stainless steel angular legs
- Stainless steel back enclosure panel
- Seismic feet
- Field stacking kit
- High Voltage (380/415/440/480)
- Casters
- Extra deep oven racks
- Prison package—tamper proof screws, lexan hinged cover with lockable clasp
- Extended warranty

Approval Stamp(s):

PRODUCT INFORMATION:

PROJECT: _____

ITEM: _____

QUANTITY: _____

MODEL:

Duke Convection Ovens Single Deck—Deep Depth—Electric

- 613-E3 Single deck, deep depth

STANDARD FEATURES

- 6 racks/13 rack positions
- Porcelain interior finish
- 65/35 stainless steel doors - dependent chain driven
- Double pane glass in 65 door
- 27" angular painted legs/adjustable feet
- 2 speed fan

OVEN SECTION

- Stainless steel front, sides and top
- 1 ½" insulation on bottom, sides and back
- 3" insulation on top
- Interior Lights

OVEN CONTROLS

- "V"—Basic snap action thermostat (200°-500°F), 60 minute electric dial timer with continuous sound buzzer, 2-speed fan
- "XX"—Solid state digital time and temperature controls, 12-hour countdown timer, **Cook and Hold** feature, 2-speed fan, Pulse fan capability

Certifications



DUKE MANUFACTURING CO.
 2305 N. Broadway
 St. Louis, MO 63102
 800.735.3853 Toll Free
 314.231.5074 Fax
 www.dukemfg.com
 SS-1068-613E3-Single-Deep-Elec

Specification subject to change



REV D 06/15/2022

DUKE CONVECTION OVENS - SINGLE - DEEP DEPTH - ELECTRIC

Catalog No. DCO-ELECS

A.I.A. File No. 35-C-13

DUKE CONVECTION OVENS

SINGLE DECK—ELECTRIC—DEEP DEPTH

A.I.A. File No. 35-C-13

Catalog No. DCO-ELECS

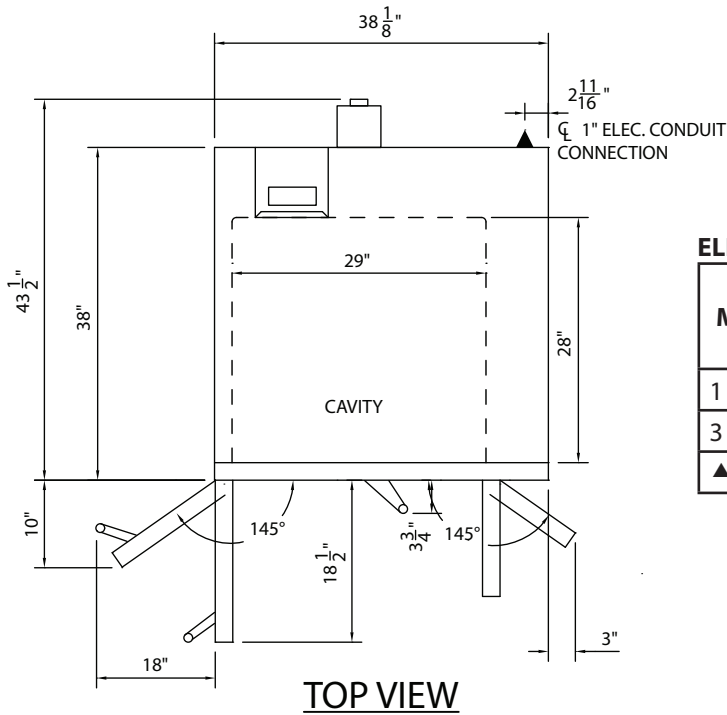

ELECTRICAL SPECIFICATIONS:

Model	208 Volt (Amps)	240 Volt (Amps)	480 Volt (Amps)	KW
1 Phase	52.8	45.8	n/a	10.0
3 Phase	30.5	26.5	13.3	10.0

▲ Electronic connection point

DUKE CONVECTION OVENS- SINGLE - DEEP DEPTH - ELECTRIC

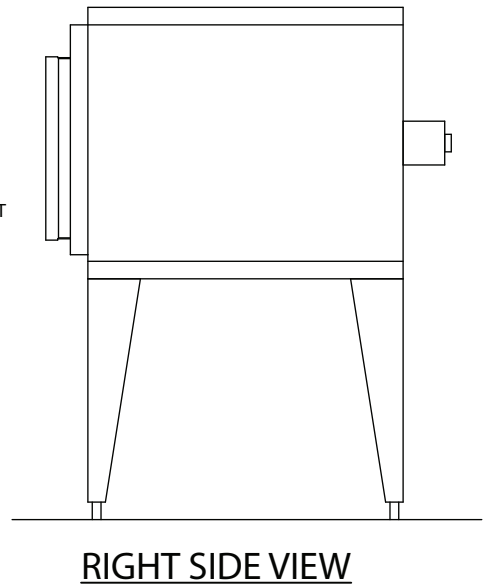
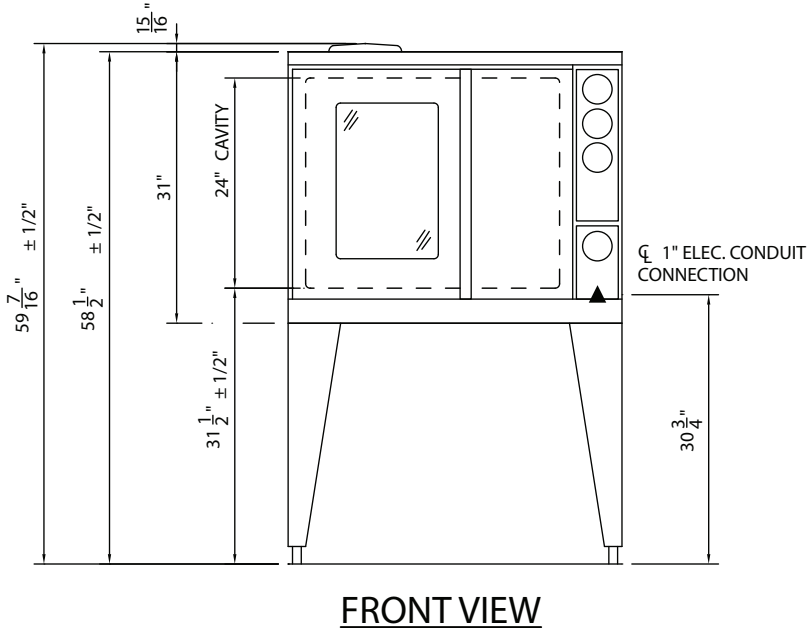

DIMENSIONS:

Freight Class: 85

Model	Height top view		Width		Depth front view		Cube ft. crated	Crated Ship Weight	
	in.	cm	in.	cm	in.	cm		lbs.	kg
613-E3	60	152.4	38	96.5	43 1/2	110.5	65.4	505	230.0



Duke Manufacturing Co.
2305 N. Broadway
St. Louis, MO 63102

Phone: 314-231-1130
Toll Free: 1-800-735-3853
Fax: 314-231-5074

www.dukemfg.com