

## "EBHS4R5" ENCLOSED BASE WORK TABLES

### 14GA Stainless Steel Top w/5" Riser - Hinged Doors

#### FEATURES:

- 14GA Stainless Steel Top With 5" Rear Riser Hinged Door Style
- Type 300 Stainless Steel With #4 Polish, Satin Finish
- Top Is Sound Deadened
- Reinforced With 1"x2" Channel Running Entire Length Of Table
- 1-1/2" Stallion Edge On Front And Rear With Side Edges 90 Degree Bend Down For Table Line-Up
- Stainless Steel Base And Undershelf
- Undershelf Is Secured In A Fixed Position, 10" Above Floor
- Shipped Standard Welded Set-Up

#### SPECIFICATIONS:

- Top: Stainless Steel Tops Are TIG Welded, Exposed Welds Are Polished To Match Adjacent Surface
- Top: 14GA Stainless Steel Type 300 Stainless Steel With #4 Polish, Satin Finish
- Shelf: 18GA Type 300 Stainless Steel, #4 Polish With Satin Finish
- Legs: 1-1/2" Square O.D., 16GA Tubular Stainless Steel
- Panels: 20GA Type 300 Stainless Steel, #4 Polish With Satin Finish
- Feet: 1" Adjustable Stainless Steel Bullet Feet



EBHS4R5-3072

#### CERTIFICATIONS:



### "EBHS4R5" ENCLOSED BASE WORK TABLES

LENGTH	# OF LEGS	24" WIDTH	WEIGHT (LBS)	30" WIDTH	WEIGHT (LBS)
36"	4	EBHS6R5-2436	145	EBHS6R5-3036	155
48"	4	EBHS6R5-2448	160	EBHS6R5-3048	170
60"	4	EBHS6R5-2460	175	EBHS6R5-3060	185
72"	4	EBHS6R5-2472	210	EBHS6R5-3072	270
84"	6	EBHS6R5-2484	250	EBHS6R5-3084	280
96"	6	EBHS6R5-2496	290	EBHS6R5-3096	320
108"	6	EBHS6R5-24108	325	EBHS6R5-30108	335
120"	6	EBHS6R5-24120	350	EBHS6R5-30120	360
132"	6	EBHS6R5-24132	380	EBHS6R5-30132	390
144"	6	EBHS6R5-24144	415	EBHS6R5-30144	425

ALL DIMENSIONS ARE TYPICAL. TOLERANCE +/- .500". JOHN BOOS & CO. RESERVES THE RIGHT TO CHANGE SPECIFICATIONS WITHOUT NOTICE.

# DETAILED SPECIFICATIONS

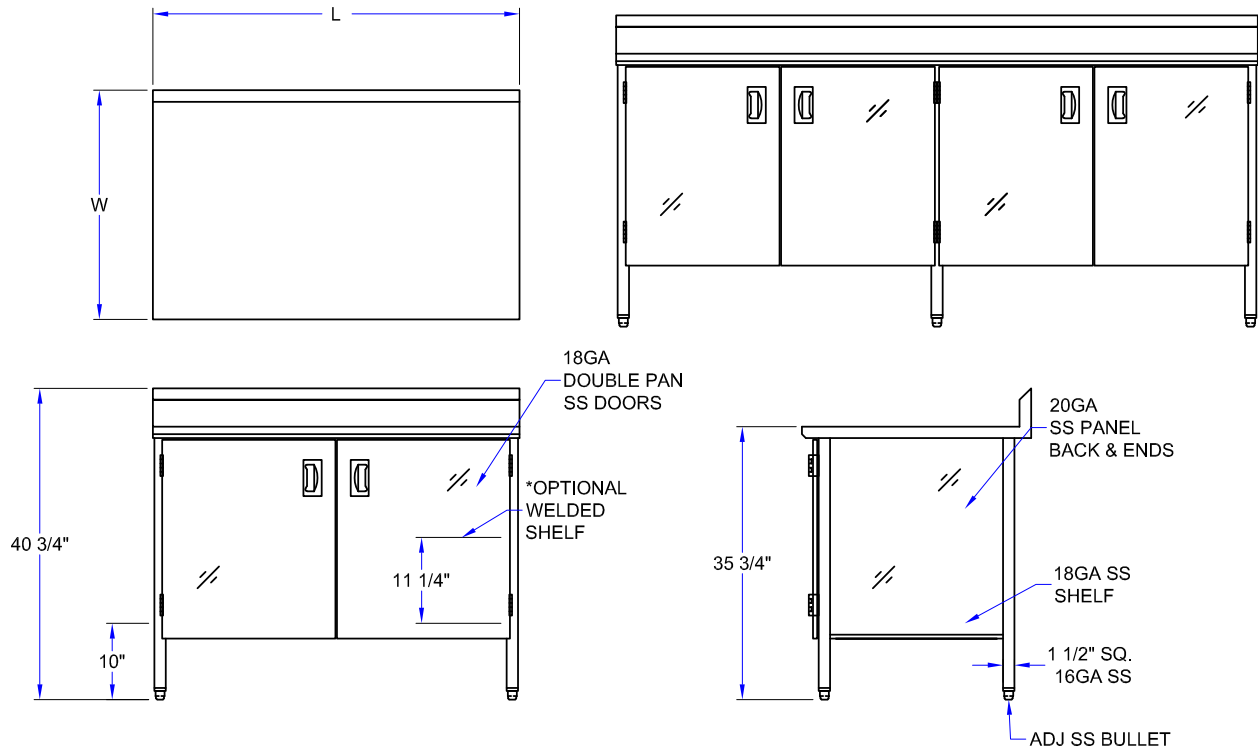

## MODEL # STRUCTURE

4 = 14GA  
 S = Stainless Steel  
 H = Hinged Doors  
 EB = Enclosed Base

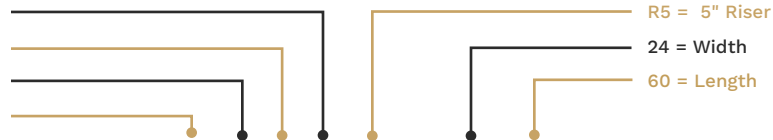

**EBHS4R5-2460**

### "EBHS4R5" ENCLOSED BASE WORK TABLES

LENGTH	# OF LEGS	24" WIDTH	WEIGHT (LBS)	30" WIDTH	WEIGHT (LBS)
36"	4	EBHS6R5-2436	145	EBHS6R5-3036	155
48"	4	EBHS6R5-2448	160	EBHS6R5-3048	170
60"	4	EBHS6R5-2460	175	EBHS6R5-3060	185
72"	4	EBHS6R5-2472	210	EBHS6R5-3072	270
84"	6	EBHS6R5-2484	250	EBHS6R5-3084	280
96"	6	EBHS6R5-2496	290	EBHS6R5-3096	320
108"	6	EBHS6R5-24108	325	EBHS6R5-30108	335
120"	6	EBHS6R5-24120	350	EBHS6R5-30120	360
132"	6	EBHS6R5-24132	380	EBHS6R5-30132	390
144"	6	EBHS6R5-24144	415	EBHS6R5-30144	425

ALL DIMENSIONS ARE TYPICAL. TOLERANCE +/- .500". JOHN BOOS & CO. RESERVES THE RIGHT TO CHANGE SPECIFICATIONS WITHOUT NOTICE.