



U-Star's 24" Narrow Depth Beer Dispensers are an easy way to offer up cold and refreshing draft beers to your patrons for work areas with limited space. These units feature stainless steel tap tower(s) that allow you to fill pint glasses and pitchers straight from the keg. Available in a wide range of sizes that can hold a number of different sized keg barrels both for use and storage. Adjustable shelves are also included for optional bottle or can storage. These units have solid black vinyl locking doors that conceal the contents inside and keep them secure after hours. The thick stainless steel top and built-in drip trays allow for easy clean-up. These models are ETL Listed, ETL Sanitation and backed by a 1 year warranty on parts and labor and a 5 year warranty on the compressor.

Product Features

- Heavy duty, wear resistant laminated black vinyl front and sides
- All stainless steel countertop, tap towers and drip trays
- Narrow 24" depth is great for work areas with limited space
- Interior is all stainless steel floor and inner walls
- 3" diameter stainless steel insulated beer columns
- Environmentally-friendly R290 refrigerant
- Side mounted compressor optimizes interior space
- Foamed-in-place polyurethane high density cell insulation throughout the entire cabinet



Specifications



Model Number	USB-4824/2	USB-6024/2	USB-7224/2
Doors	2	2	3
Taps Towers	1	2	2
Kegs (Half Barrels)	2	2	3
Net Volume (Cu. Ft.)	11.8 Cu. Ft.	15.8 Cu. Ft.	19.6 Cu. Ft.
Overall Dimensions (in)	48.75" x 24.5" x 36.25"	60.75" x 24.5" x 36.25"	72.75" x 24.5" x 36.25"
Interior Dimensions (in)	36" x 18.5" x 29"	48" x 18.5" x 29"	60" x 18.5" x 29"
Refrigerant	R290	R290	R290
Horsepower	1/5	1/5	1/4
Voltage/Hertz/Phase	115/60/1	115/60/1	115/60/1
Amps	3	3	4
Net Weight (lbs)	187 lbs	247 lbs	309 lbs
Gross Weight (lbs)	231 lbs	291 lbs	353 lbs
Shipping Dimensions (in)	51" x 27.5" x 41.7"	62" x 27.5" 41.7"	75" x 27.5" 41.7"

Plan Views

USBD-4824/2

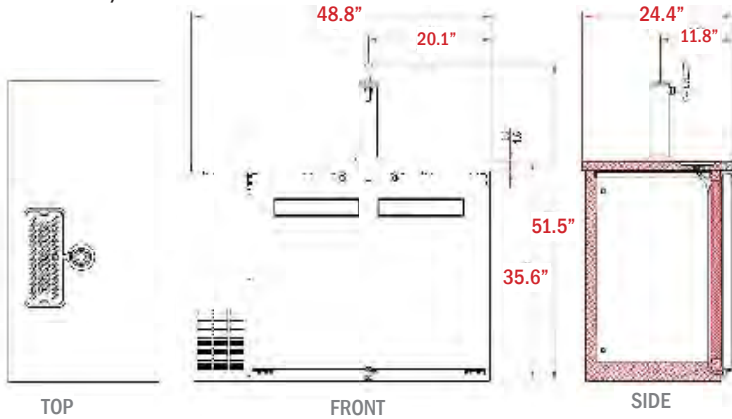

USBD-6024/2

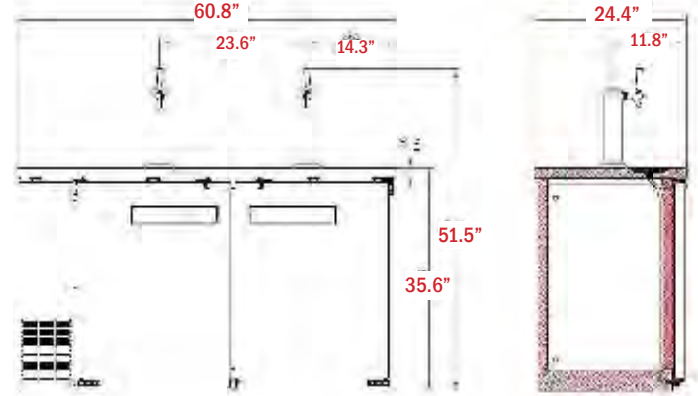

USBD-7224/2

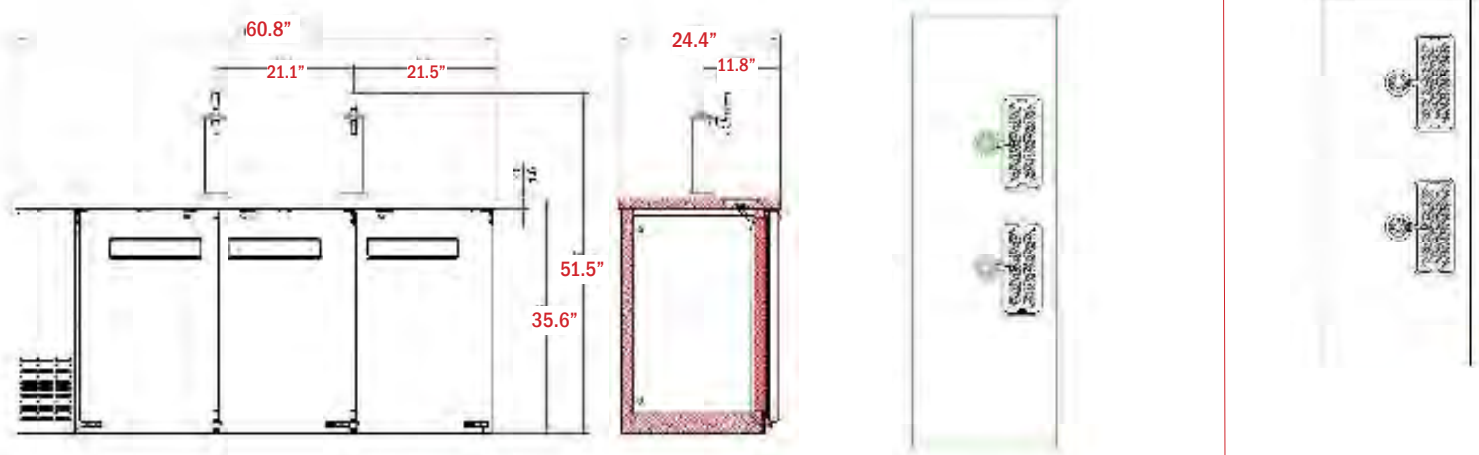

Features

Cooling System

- Refrigeration units use environmentally friendly R290 refrigerant
- Balanced refrigeration system helps to maintain a temperature range of 33° F–38° F
- Condensing unit is located behind front grill and slides out for easy cleaning

Electrical Control

- 115V/60 connection for all models
- 7' power cord with NEMA 5-15 plug from the back of the unit



Cabinet Construction

- Exterior is constructed of a durable black vinyl front and sides with an aluminum back with an all stainless steel countertop
- Interior is constructed of all stainless steel floor and walls
- 3" diameter stainless steel insulated beer columns that has cold air directed into them to reduce foaming
- The cabinet is insulated throughout with a foamed-in-place high density cell polyurethane insulation
- Narrow 24" depth is ideal for areas with limited workspace

Shelving

- Heavy duty PVC coated wire shelves are adjustable
- Aluminum shelf support system that are adjustable for every 1/2"

Model Features

- Interior LED lighting for greater visibility throughout the cabinet
- Couplers included

Doors

- Laminated black vinyl exterior with heavy gauge steel liner
- 12" long recessed handles
- Positive seal doors
- Door locks come standard on all models