

- **NR3620DSV** 35-3/4"L x 32-5/8"D x 20-3/8"H
- **NR4820DSV** 47-3/4"L x 32-5/8"D x 20-3/8"H

Included

- NOTE: Glass warranty only applicable to first point of delivery
- NOTE: Cannot be joined case to case
- (1) Level of clear glass shelving removable and adjustable on 1" centers
- LED top & shelf lights
- One year parts & labor warranty
- Vertical, fixed front & side UV bonded frameless glass

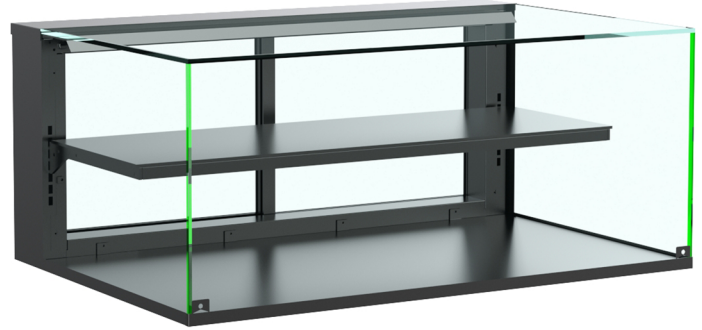

NR4820DSV

Specify	Standard Features	Additional Options
FRAME EXTERIOR COLOR	<ul style="list-style-type: none"> • Powder coated Silversan Black 	<ul style="list-style-type: none"> • Powder coated (stock/non-stock colors) • Stainless steel
INTERIOR COLOR	<ul style="list-style-type: none"> • Powder coated Silversan Black 	<ul style="list-style-type: none"> • NOTE: Interior color must be FDA & NSF approved • Powder coated (stock colors, specify RAL#) • Stainless steel
REAR DOORS	<ul style="list-style-type: none"> • Clear glass rear sliding doors 	<ul style="list-style-type: none"> • Reflective glass rear sliding doors
LIGHTS	<ul style="list-style-type: none"> • LED 3500K w/ frosted lens 	<ul style="list-style-type: none"> • LED 3000K w/ frosted lens • LED 4000K w/ frosted lens
ELECTRICAL CONNECTION	<ul style="list-style-type: none"> • 6' Straight blade power cord 	<ul style="list-style-type: none"> • 6' Locking blade power cord • Electrical leads (non-refrigerated)
MISCELLANEOUS		<ul style="list-style-type: none"> • Rear door lock • Second year parts & labor warranty

Intended Environment: Type I - Designed to operate in ambient conditions of 75°F with 55% relative humidity unless noted otherwise in system information below.		
Zone	Intended Product To Be Displayed	Warmest Avg Prod Temp ° F
1	Unpackaged non-refrigerated products	Ambient

REAR VIEW

PLAN VIEW

SIDE VIEW

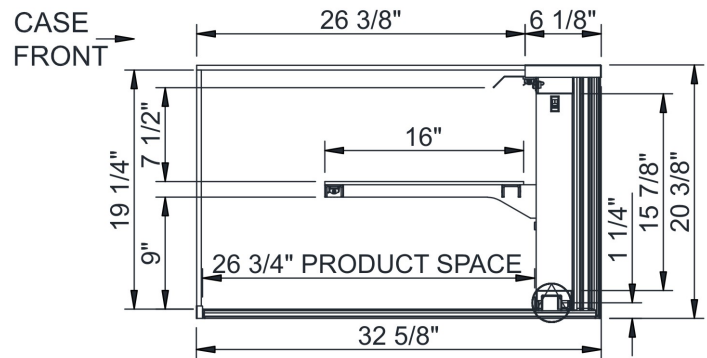
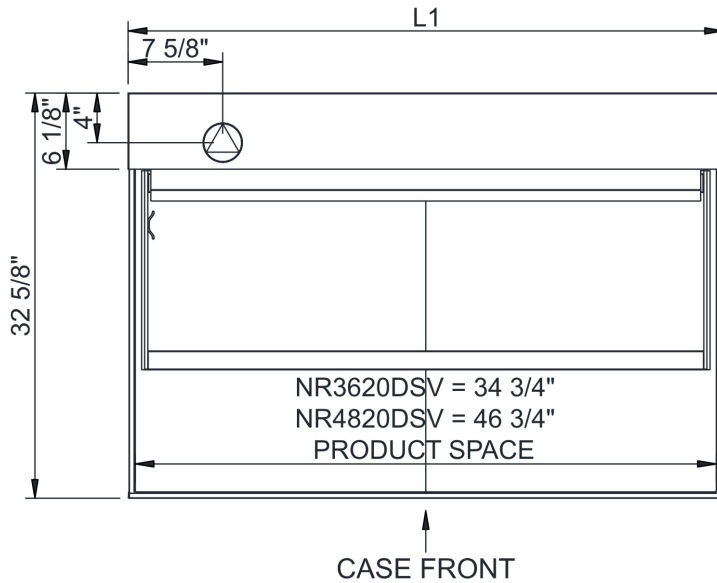

NOTE: ALL DIMENSIONS APPROXIMATE

- ELECTRICAL JUNCTION BOX (SUPPLIED WITH 6" LEADS OR POWER CORD).
- LOCATION OF DRAIN TUBE FOR REMOTE REF. ONLY (SUPPLIED WITH 3/4" OR 1 1/2" PVC TUBE).

- REFRIGERATION LINE CONNECTION.
- REMOTE FLOOR SINK & UTILITIES ACCESS AREA.

- SELF-CONTAINED CASE SERVICE ACCESS AREA.
- DRY CASE SERVICE ACCESS AREA.

Model Technical Specifications																	
Model	L"	L1"	L2"	System Circuit Volts			Phs	Freq	Amps ***	Watts	Wires	NEMA Plug	SST	Conv. Rack BTUH	Para. Rack BTUH	Est Wt	
NR3620DSV	N/A	35.75	.00	Ambient/Lights (N/A)			Circuit #1	110-120	1	60	0.70	8	2+G	5-15P or L5-15P	N/A	N/A	350
NR4820DSV	N/A	47.75	.00	Ambient/Lights (N/A)			Circuit #1	110-120	1	60	0.70	11	2+G	5-15P or L5-15P	N/A	N/A	450

*** Does not include electric defrost on freezer models.

Regulatory Approvals:	
All Models	ETL Listed to UL 65 ETL Sanitation to NSF/ANSI 2



Important Notes:

- 1) ELECTRICAL NOTE: If GFCI is required, a GFCI breaker MUST be used in lieu of a GFCI receptacle
- 2) Glass warranty only applicable to first point of delivery.
- 3) Cannot be joined case to case.

⚠ WARNING: This product can expose you to chemicals, including Urethane (Ethyl Carbamate), which are known to the State of California to cause cancer and birth defects or other reproductive harm. For more information go to www.P65Warnings.ca.gov.